



# XP-8x41 Quick Start

Version 2.4, October 2016

## Supported Modules

- XP-8041
- XP-8341
- XP-8741

## What's in the Box?

In addition to this guide, the package includes the following items:



XP-8x41



CF slot  
with a CF card



Software  
Utility CD



Screw Driver  
2.4 mm

## Technical Support

- XP-8000 User Manual

CD:\XP-8000\Document\User\_Manual\

[ftp://ftp.icpdas.com/pub/cd/xp-8000/document/user\\_manual/](ftp://ftp.icpdas.com/pub/cd/xp-8000/document/user_manual/)

# 1 Configuring the Boot Mode

Before starting any installation, be sure that the switch is placed in the 『0』 position.

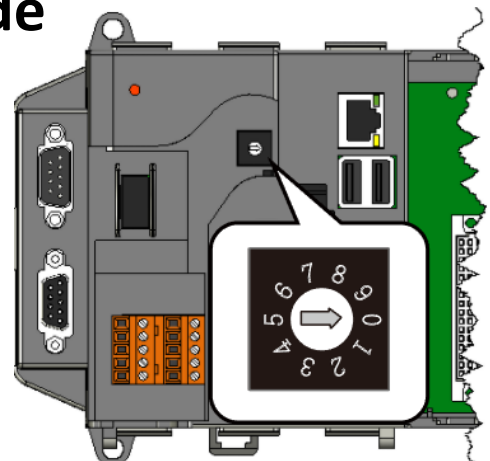

## 2 Connecting to PC, Monitor and Power Supply

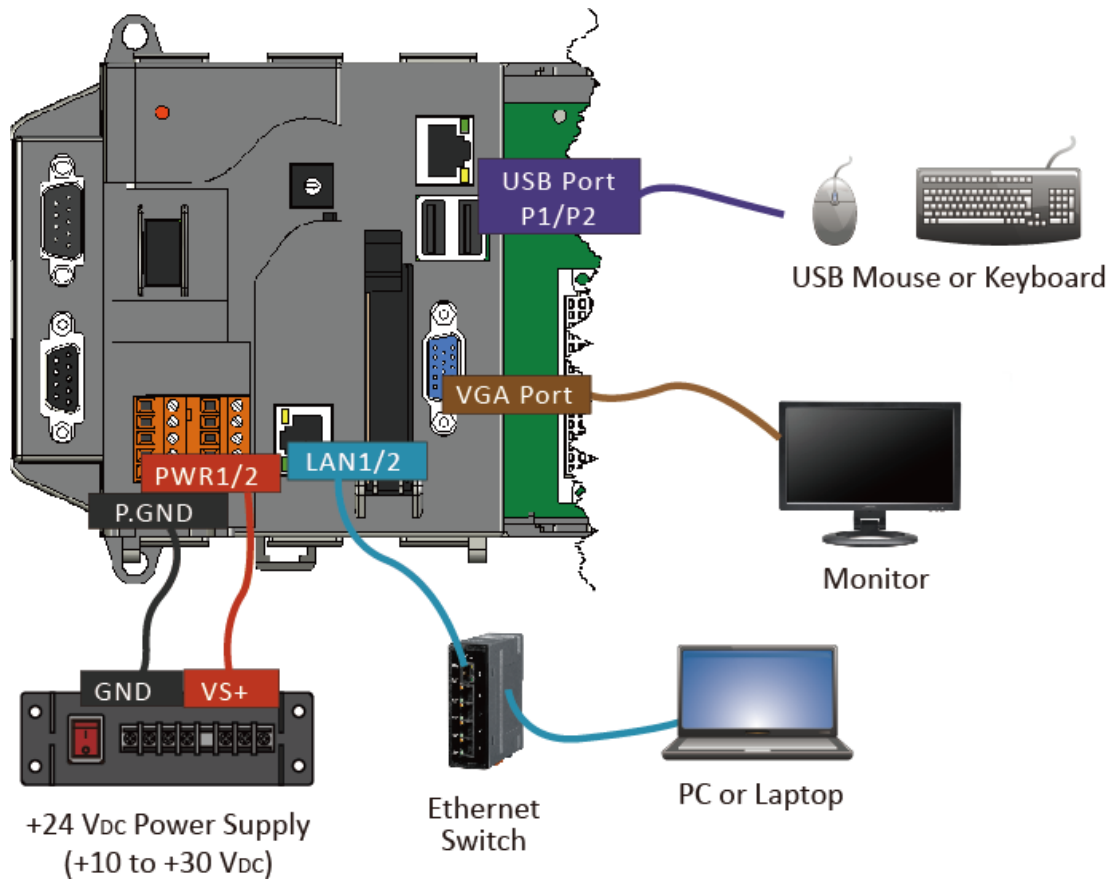

## 3 Changing the User Interface Language

PAC Utility allows users to easily change the XP-8x41 user interface with your native language.

- 1) Double-click the PAC Utility on the desktop

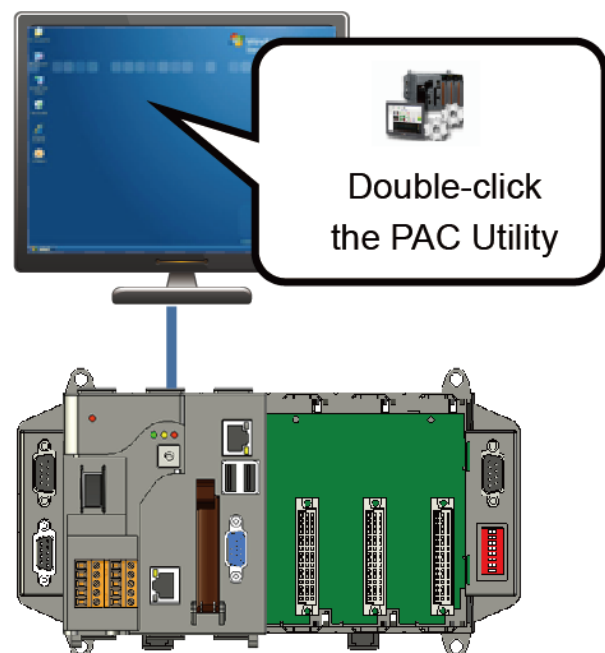

- 2) Click the Language Setting tab, choose your preferred language that you want to use for XP-8x41 menus and dialogs, and then click Apply button

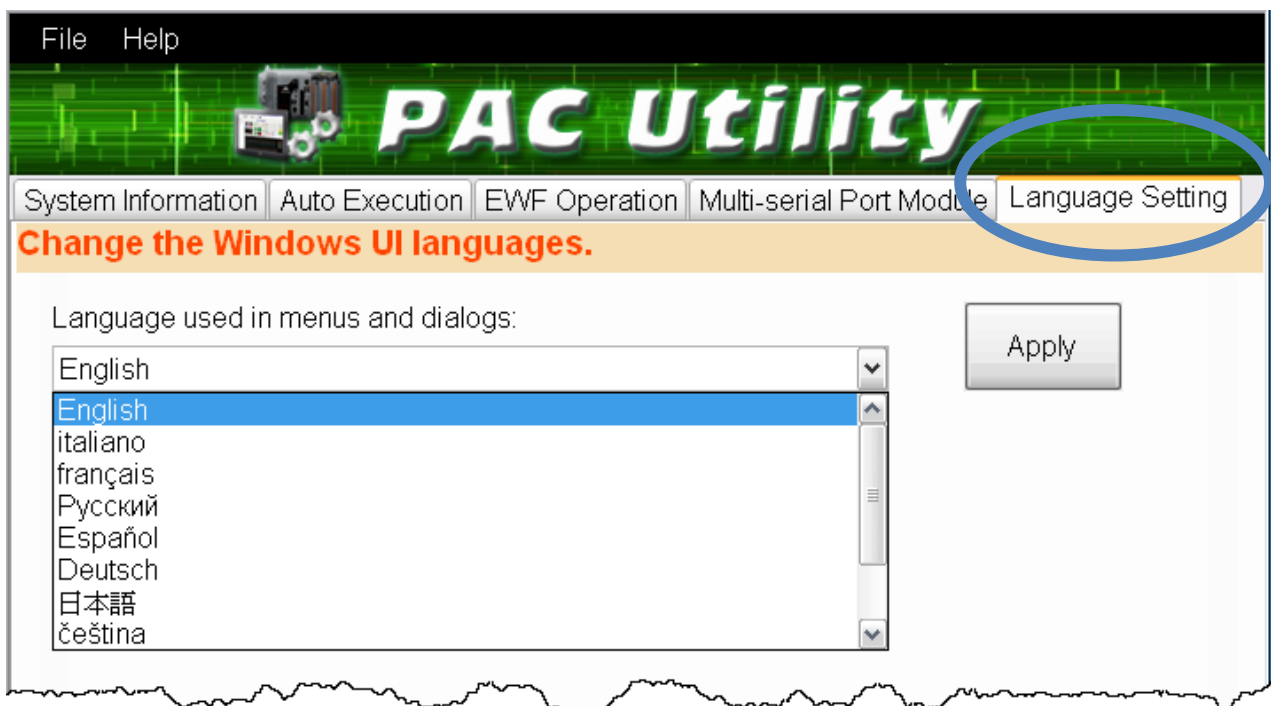

- 3) Click the EWF Operation tab, select the Commit option, and then click Apply button

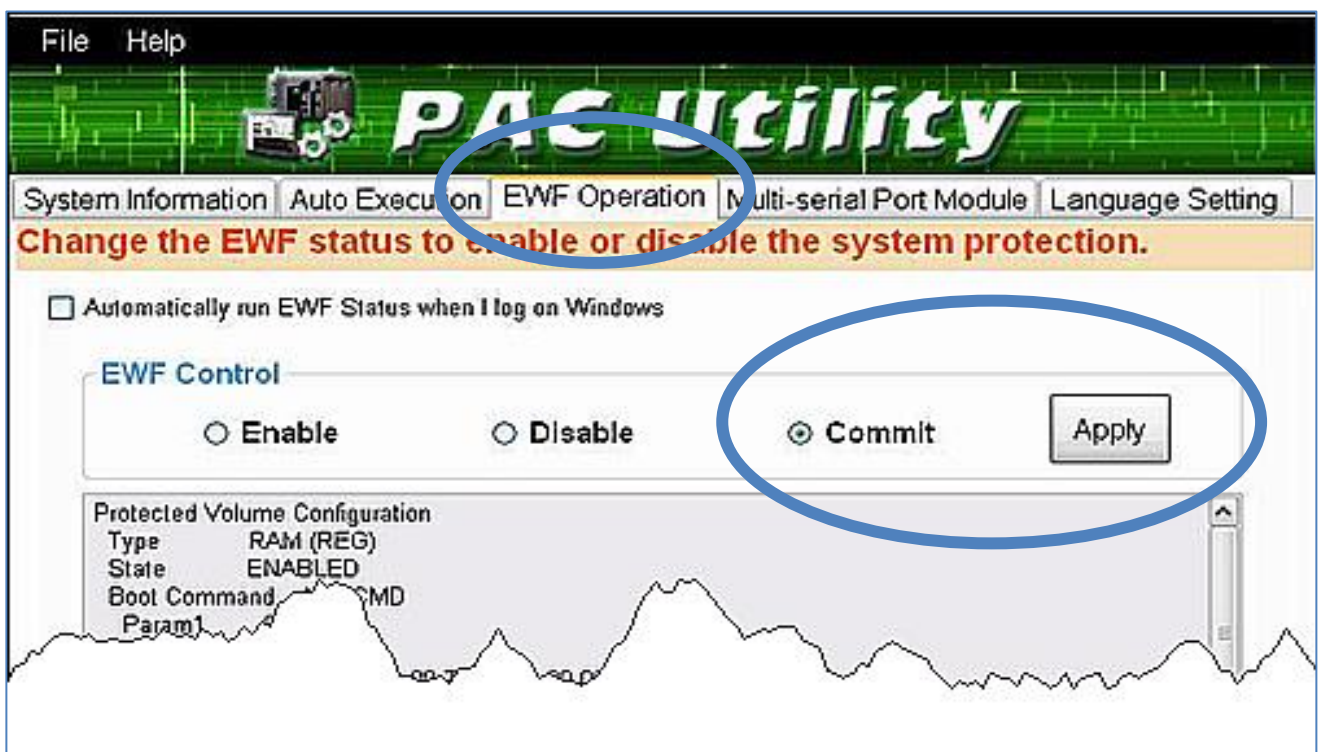

4) Click OK button to save changes to the disk

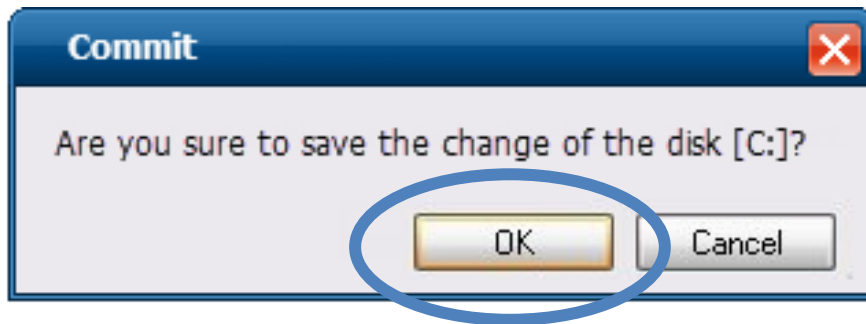

5) Log off the XP-8x41, and then login again for changes to take effect.

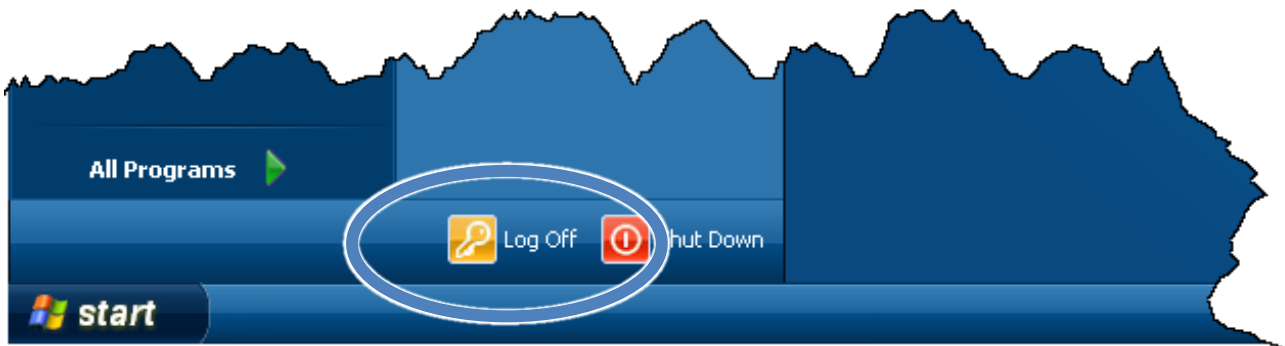

## Tips

---



The Enhanced Write Filter (EWF) is a Windows XP embedded utility for protecting the C:\ drive of the XP-8x41. If you need to change any of the settings you have configured, you must manage the EWF to commit the changes on the next login or next reboot. These changes will take effect on the login or next reboot.

---

# 4

## Inserting the I/O Module and Wiring Connection

XP-8341/XP-8741 has 3/7 I/O expansion slots and only supports I-8K and I-87K series I/O modules.

For more information about this expansion I/O modules, please refer to

[http://www.icpdas.com/root/product/solutions/pac/ippc/pac-family\\_io\\_expansion.html](http://www.icpdas.com/root/product/solutions/pac/ippc/pac-family_io_expansion.html)

- 1) Align circuit card with slot and press firmly to seat module into connector

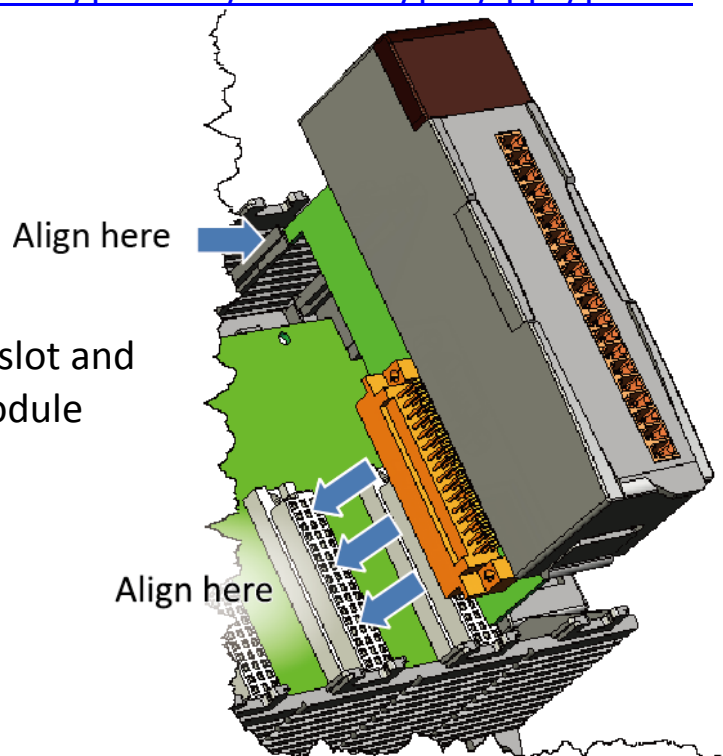

- 2) Pull top and bottom locking tabs toward module face. Click indicates lock is engaged

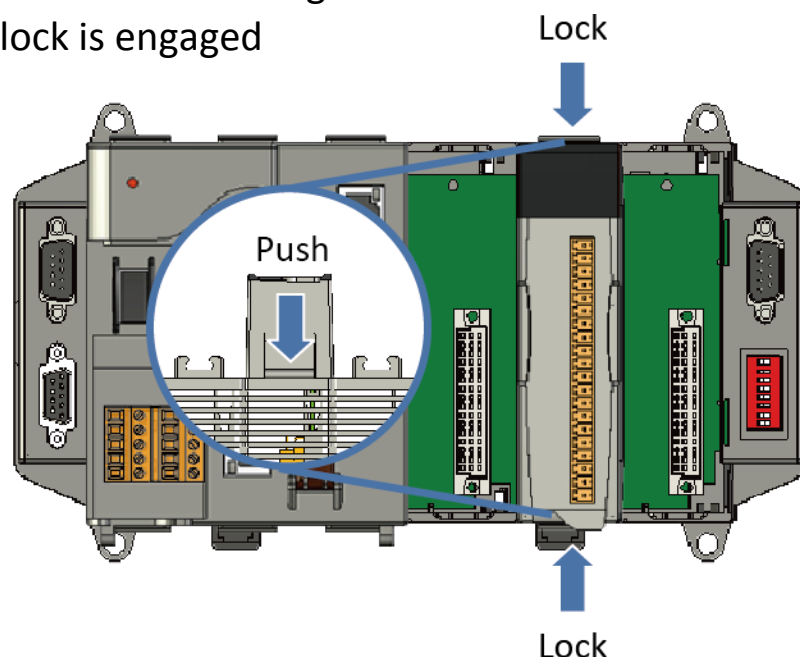

3) Attach field wiring using the terminal block, and then insert the terminal block

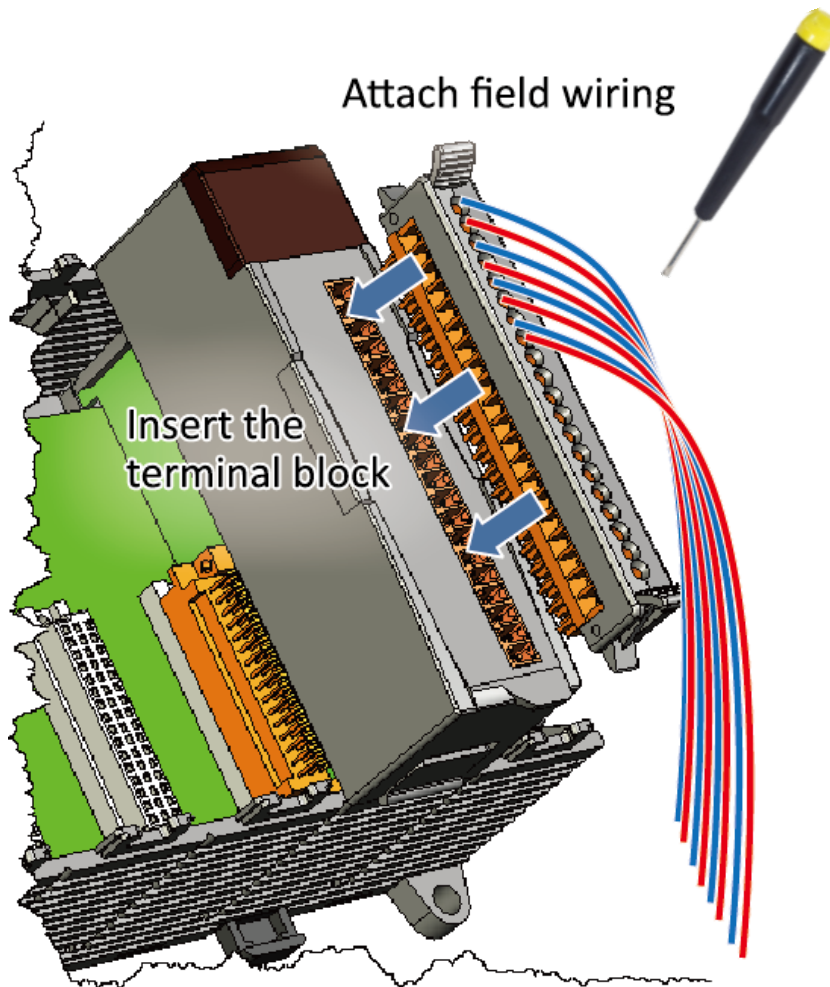

All I/O Web Page include the I/O module specifications, pin assignments and wiring connections.

For example, Pin Assignments and Wiring connections for the I-87054W module are as follows:

[http://www.icpdas.com/root/product/solutions/remote\\_io/rs-485/i-8k\\_i-87k/i-87054w.html](http://www.icpdas.com/root/product/solutions/remote_io/rs-485/i-8k_i-87k/i-87054w.html)

# 5 Configuring I/O Modules

DCON Utility Pro is a toolkit that can help user easily to search, configure and test I/O modules.

1) Double-click the DCON Utility Pro on the desktop



2) Click the  button

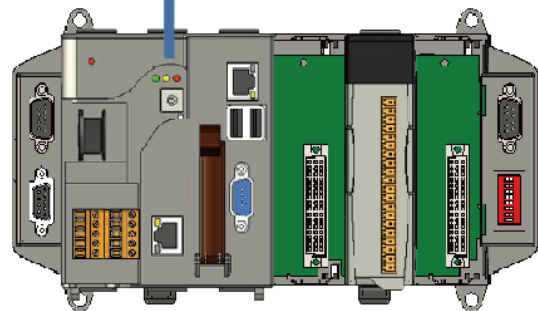

3) Configure the communication settings

The default communication settings of I/O slot are COM1.

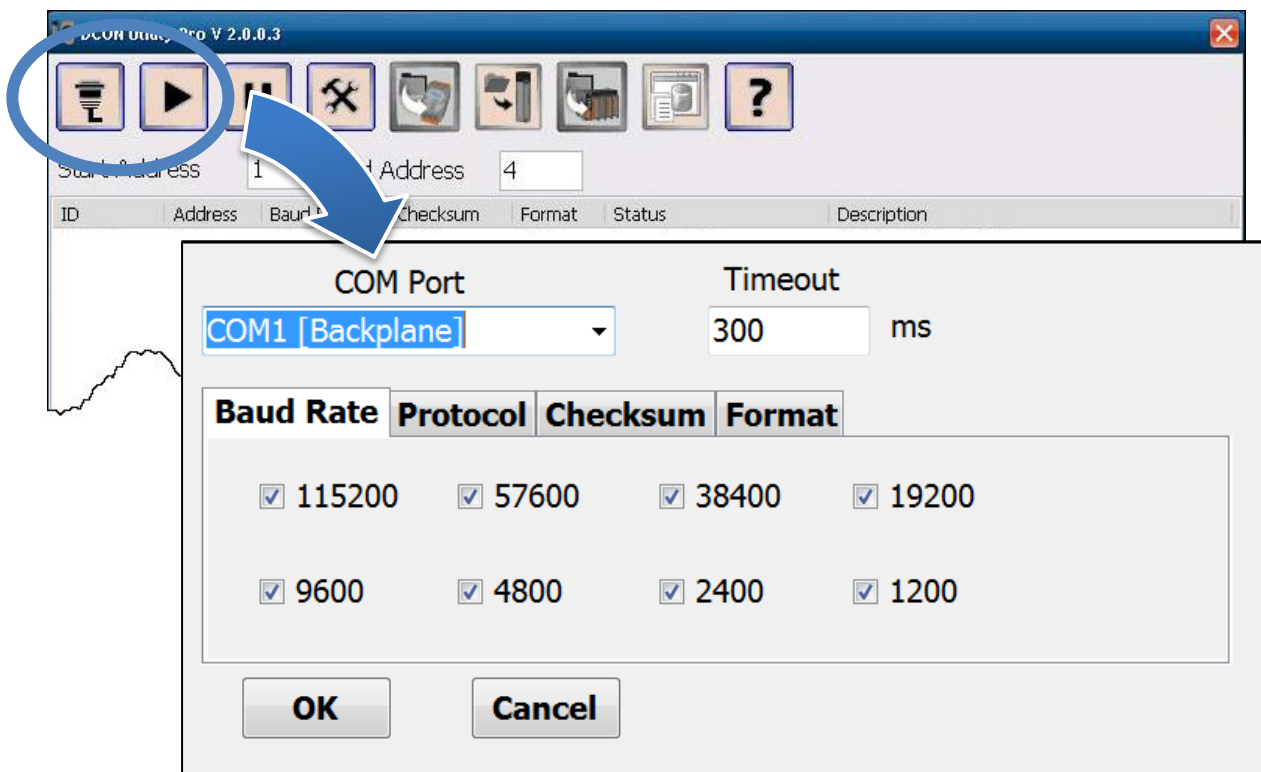

4) Click the  button

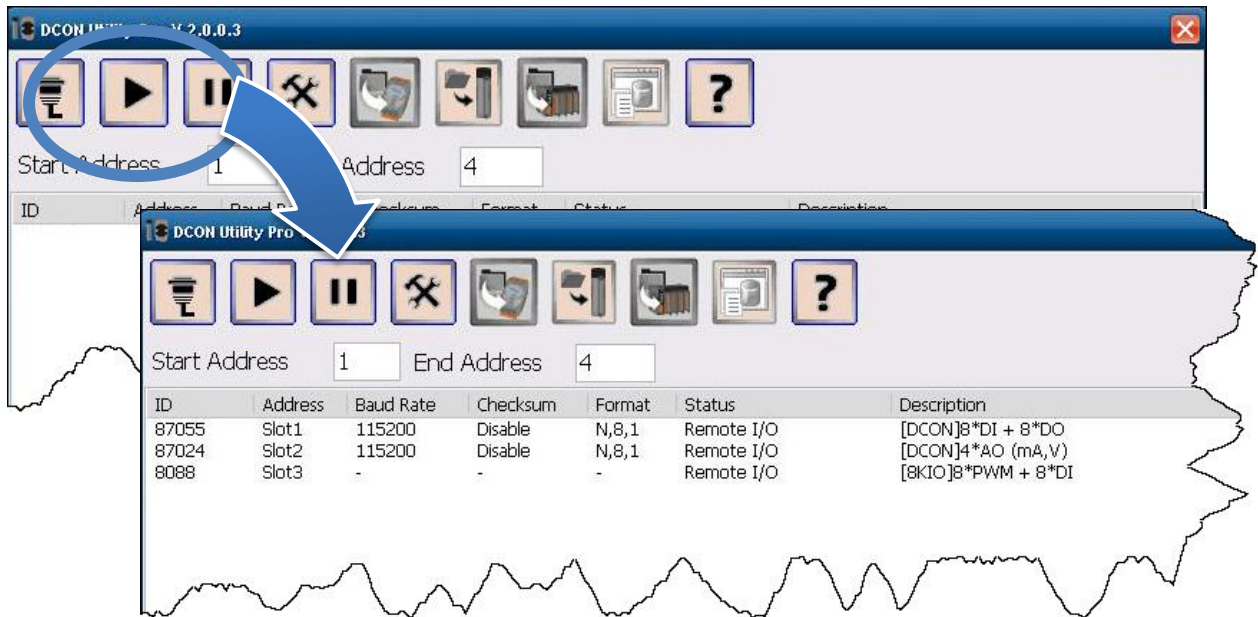

5) Click the module name to enter the I/O configuration form

