

# M2M RTU Library

## User's Manual

### **Warranty**

All products manufactured by ICP DAS are warranted against defective materials for a period of one year from the date of delivery to the original purchaser.

### **Warning**

ICP DAS assume no liability for damages consequent to the use of this product. ICP DAS reserves the right to change this manual at any time without notice. The information furnished by ICP DAS is believed to be accurate and reliable. However, no responsibility is assumed by ICP DAS for its use, nor for any infringements of patents or other rights of third parties resulting from its use.

### **Copyright**

Copyright 2010 by ICP DAS. All rights are reserved.

### **Trademark**

The names used for identification only maybe registered trademarks of their respective companies.

# Tables of Content

|  |           |
|--|-----------|
| <b>1. Overview .....</b>                   | <b>3</b>  |
| <b>2. Flowchart of using M2M APIs.....</b> | <b>7</b>  |
| <b>3. Install Library and Demo.....</b>    | <b>8</b>  |
| <b>4. Function Description .....</b>       | <b>12</b> |
| <b>5. Data format definiens .....</b>      | <b>34</b> |
| <b>6. Type code definiens .....</b>        | <b>35</b> |

## 1. Overview

ICP DAS M2M RTU Library is a software tool package for M2M RTU products. It provides the seamless connection with M2M RTU products (G-4500 RTU, GT-540...) of ICP DAS for the user-designed system. With the APIs in this library, programmer can access M2M RTU devices by public software development environments, like VC, VB, BCB, visual studio.Net... It is easy to integrate these GPRS RTU devices to various applications including real the remote data, database management system.

Therefore, the Library can help users to apply the ICP DAS M2M RTU products in their applications to monitor the data and sends them out in real time to the control center through GPRS or Ethernet Network. Also, by combining a GPS (optional) with M2M GPRS RTU, they suddenly become a tracking system which you can often find out in the car system, marine system, etc.

## Features

- Provide simple API functions for users to reduce the development time
- Easy to perform M2M RTU devices status monitoring and control
- Up to 128 M2M RTU devices can be managed
- Help users to connect to any Modbus device to GPRS/Ethernet
- Easily manage and control distributed remote devices via GPRS/Ethernet
- Support for M2M GPRS RTU products of ICP DAS

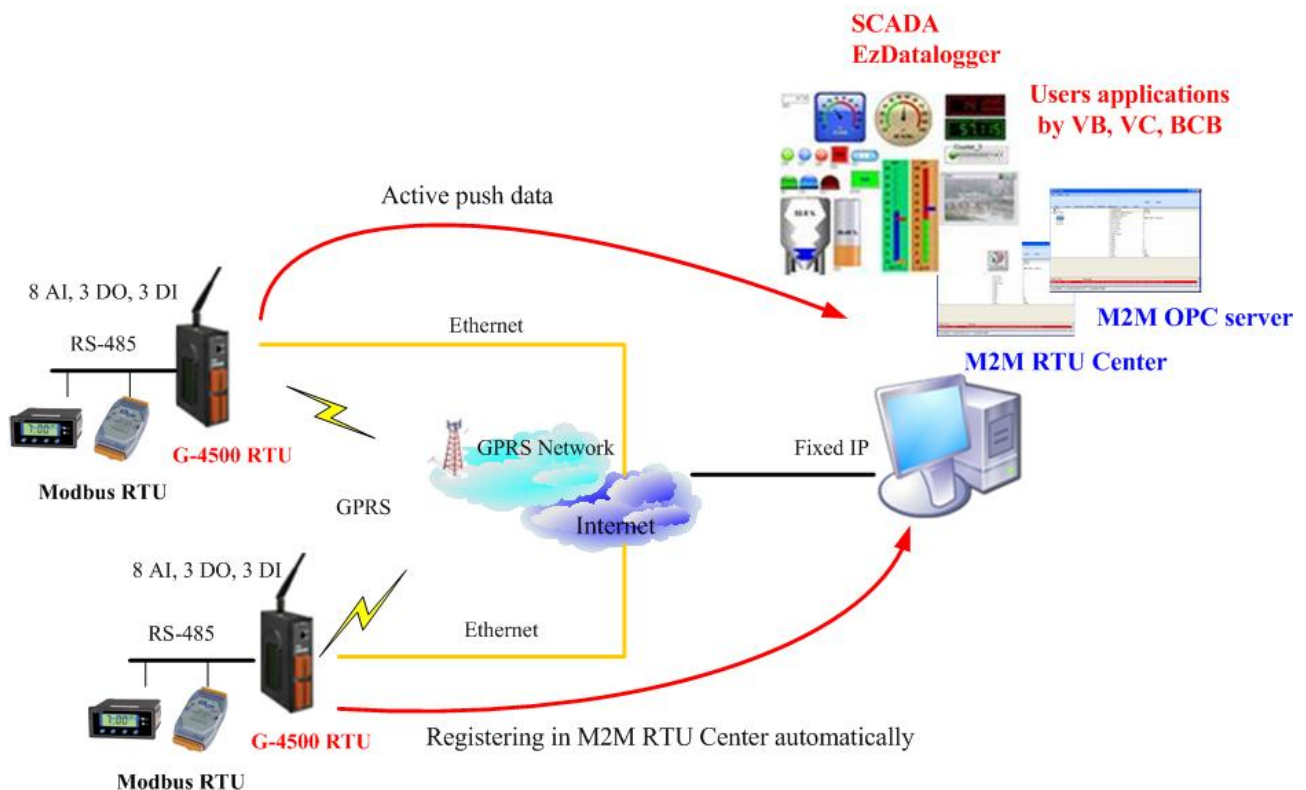

## Software Architecture

In order to reduce the load of developing application, the architecture of M2M RTU solutions for users is as the following figure. M2M RTU Center software would manage the connection from M2M RTU devices. M2M RTU Library can help engineers to access data from M2M RTU Center software. Therefore, programmer just focuses on the applications

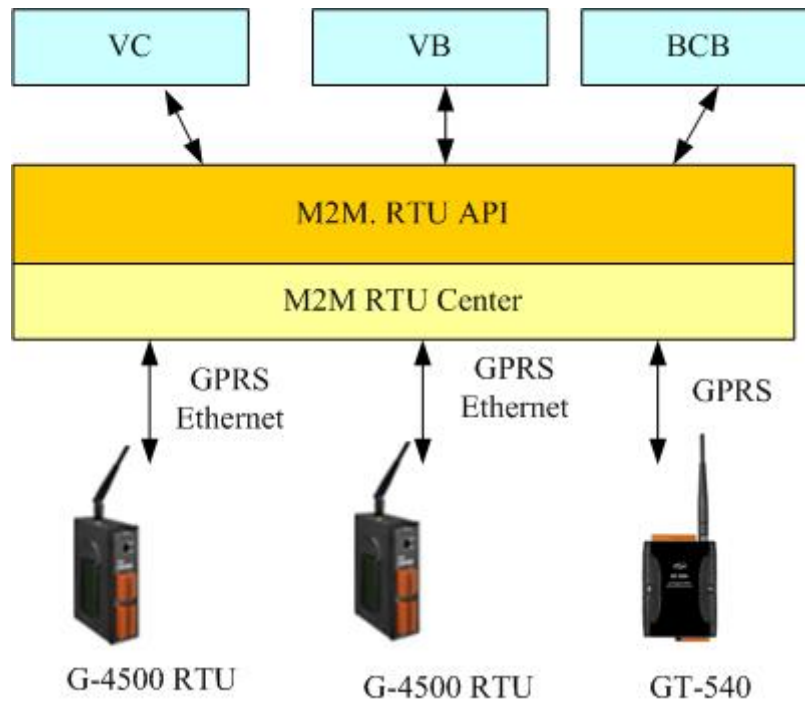

## Support Hardware

| Product Type              | Description   |
|---------------------------|---|
| <b>G-4500-SIM300 CR</b>   | Tri-band M2M Mini-Programmable Automation Controller (RoHS)                                   |
| <b>G-4500D-SIM300 CR</b>  | Tri-band M2M Mini-Programmable Automation Controller with LCD display (RoHS)                  |
| <b>G-4500P-SIM300 CR</b>  | Tri-band M2M Mini-Programmable Automation Controller with GPS function (RoHS)                 |
| <b>G-4500PD-SIM300 CR</b> | Tri-band M2M Mini-Programmable Automation Controller with LCD display and GPS function (RoHS) |
| <b>G-4500-SIM340 CR</b>   | Quad-band M2M Mini-Programmable Automation Controller (RoHS)                                  |
| <b>G-4500D-SIM340 CR</b>  | Quad-band M2M Mini-Programmable Automation Controller with LCD display (RoHS)                 |
| <b>G-4500P-SIM340 CR</b>  | Quad-band M2M Mini-Programmable Automation Controller with GPS function (RoHS)                |
| <b>G-4500PD-SIM340 CR</b> | Quad-band M2M Mini-Programmable Automation  |

|                            |  |
|----------------------------|--|
|                            | Controller with LCD display and GPS function (RoHS)  |
| <b>GD-4500-SIM340 CR</b>   | Quad-band M2M Mini-Programmable Automation Controller (RoHS)                                   |
| <b>GD-4500D-SIM340 CR</b>  | Quad-band M2M Mini-Programmable Automation Controller with LCD display (RoHS)                  |
| <b>GD-4500P-SIM340 CR</b>  | Quad-band M2M Mini-Programmable Automation Controller with GPS function (RoHS)                 |
| <b>GD-4500PD-SIM340 CR</b> | Quad-band M2M Mini-Programmable Automation Controller with LCD display and GPS function (RoHS) |

## System Requirements

### Hardware requirement

|     |                                    |
|-----|------------------------------------|
| CPU | Intel Pentium (Pentium 4 or above) |
| RAM | 512 MB                             |
| HD  | 500 MB                             |

### Software requirement

|    |  |
|----|--|
| OS | Windows 2000, Windows XP, Windows Vista, Windows 7 |
|    | Microsoft .NET Framework Version 2.0 or above      |

## Application

- Digital Signage
- Energy Management
- HVAC & Refrigeration
- Security & Access Control
- Vehicle tracking system

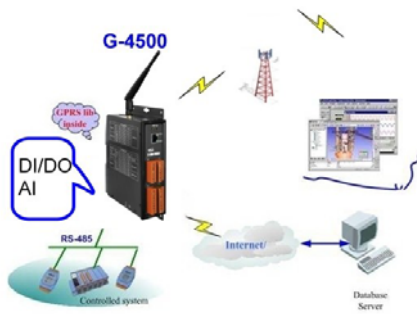

Remote Control/Monitor System

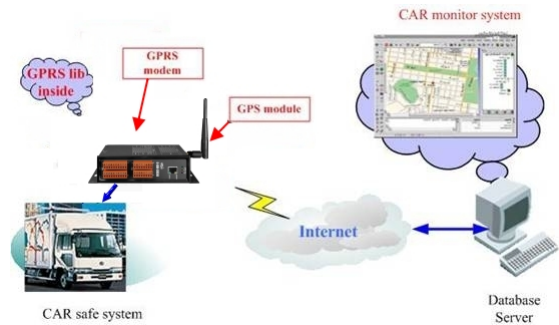

Car Monitor System

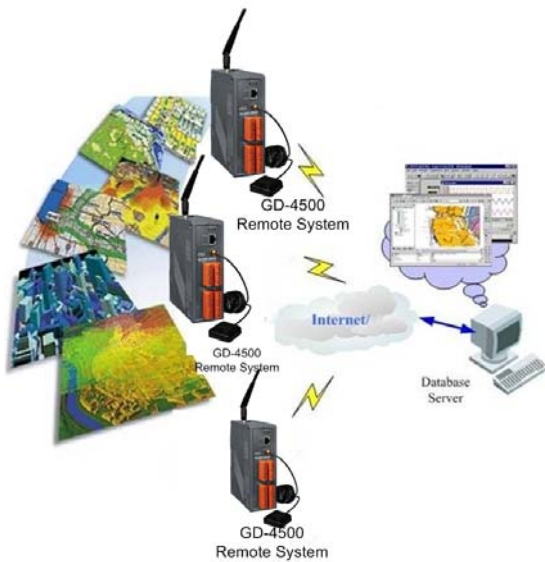

GIS system

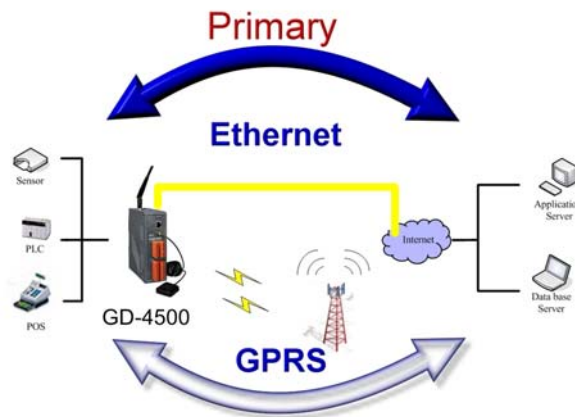

Redundant Communication System

## 2. Flowchart of using M2M APIs

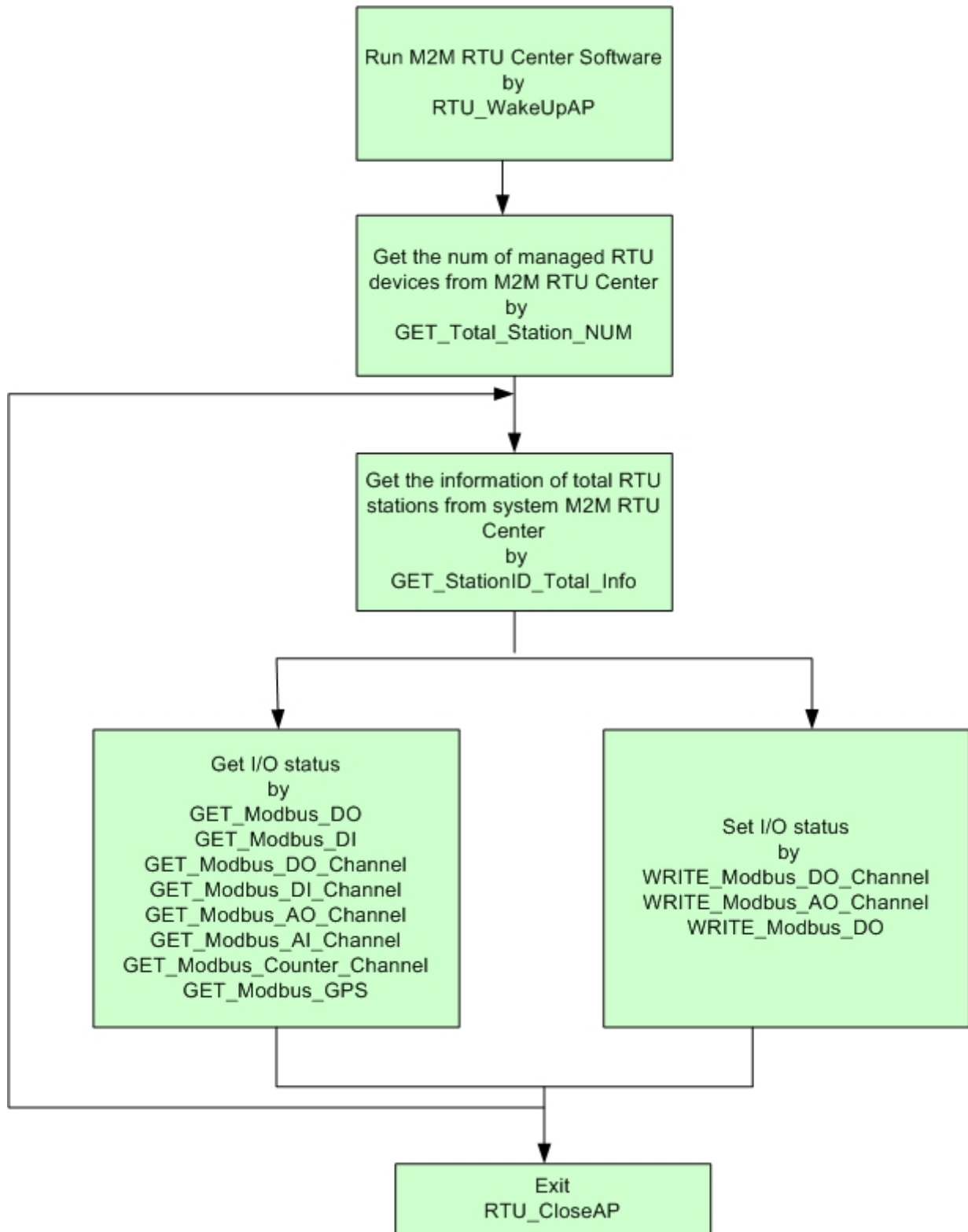

### 3. Install Library and Demo

```
M2M_RTU_API
|
|--\Manual
|   |--\M2M_RTU_API_Manual.pdf
|   |
|--\Software
|   |--\RTU_Center
|       |--\RTU_Center.exe
|       |--\M2M_RTU.dll
|       |
|   |--\Demo
|       |--\VB6
|       |--\VC6
|       |--\DOT_NET
```

The install figure is as follows:

- ◆ Press “Next” to the next step.

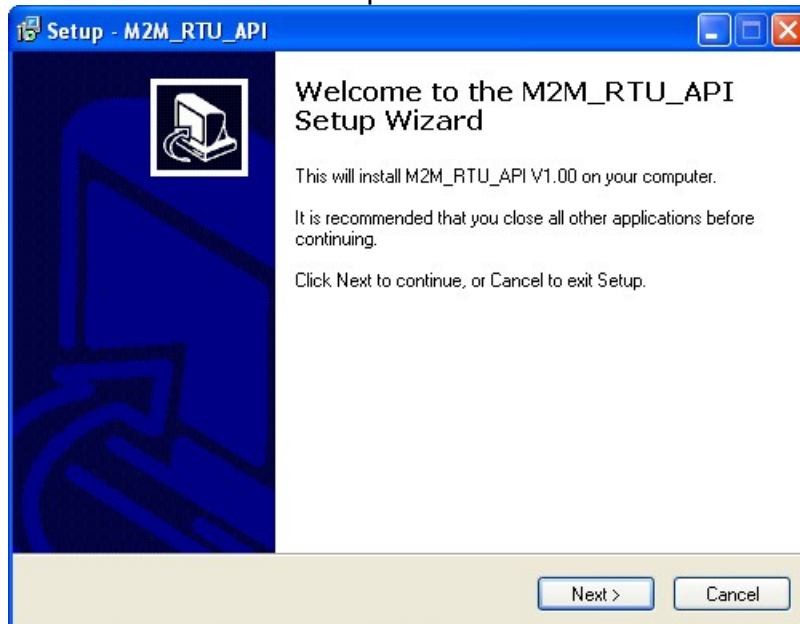



- ◆ Press "Next" to the next step.

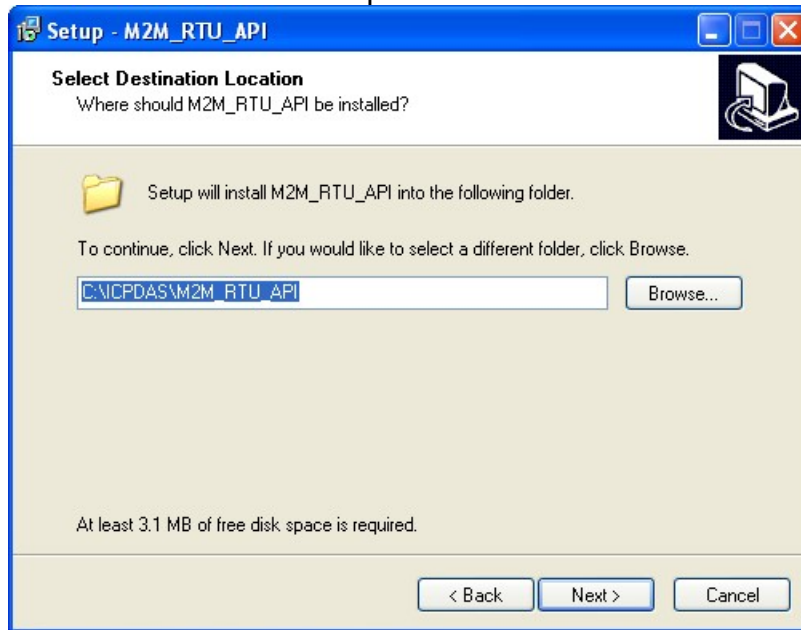

- ◆ Press "Next" to the next step.

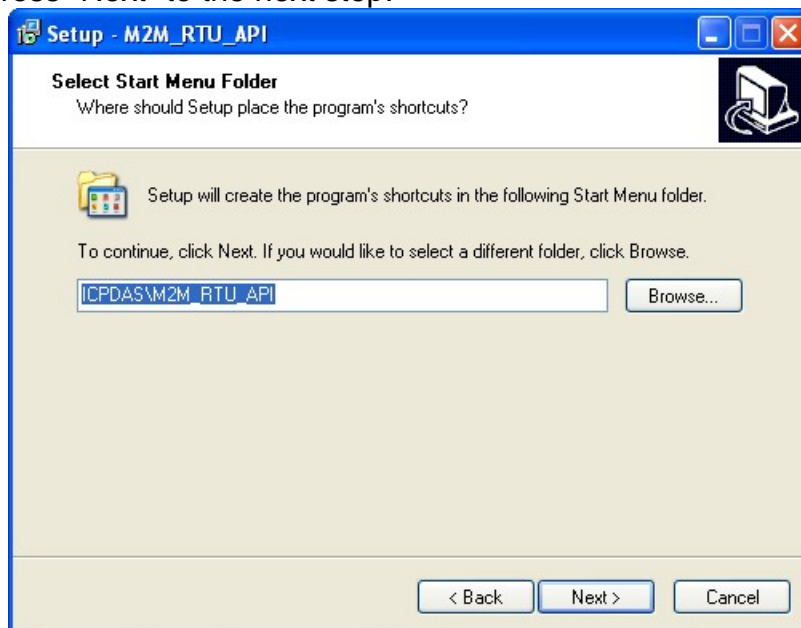

- ◆ Press "Install" to the next step.

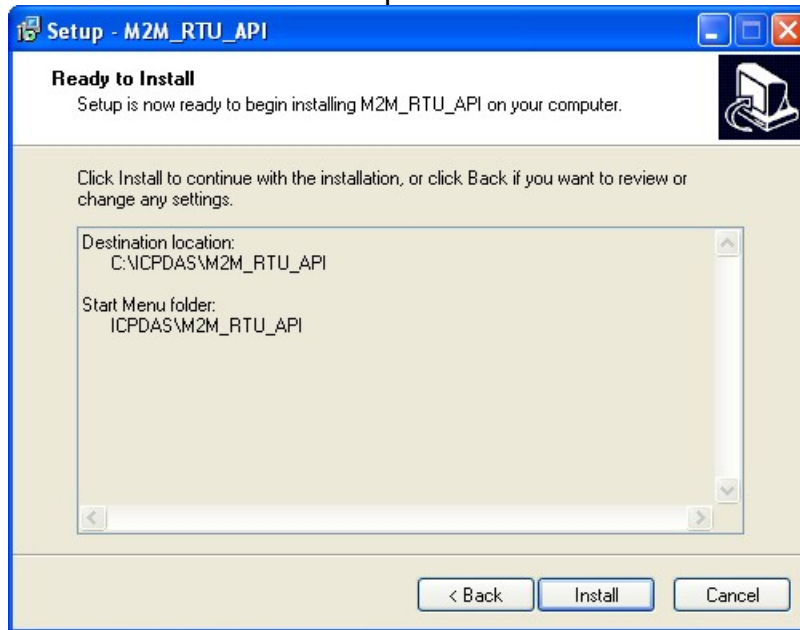

- ◆ Press "Finish".



- ◆ Launch M2M RTU API from the start menu "Start→All Programs→ICPDAS→M2M\_RTU\_API→ M2M\_RTU\_API".

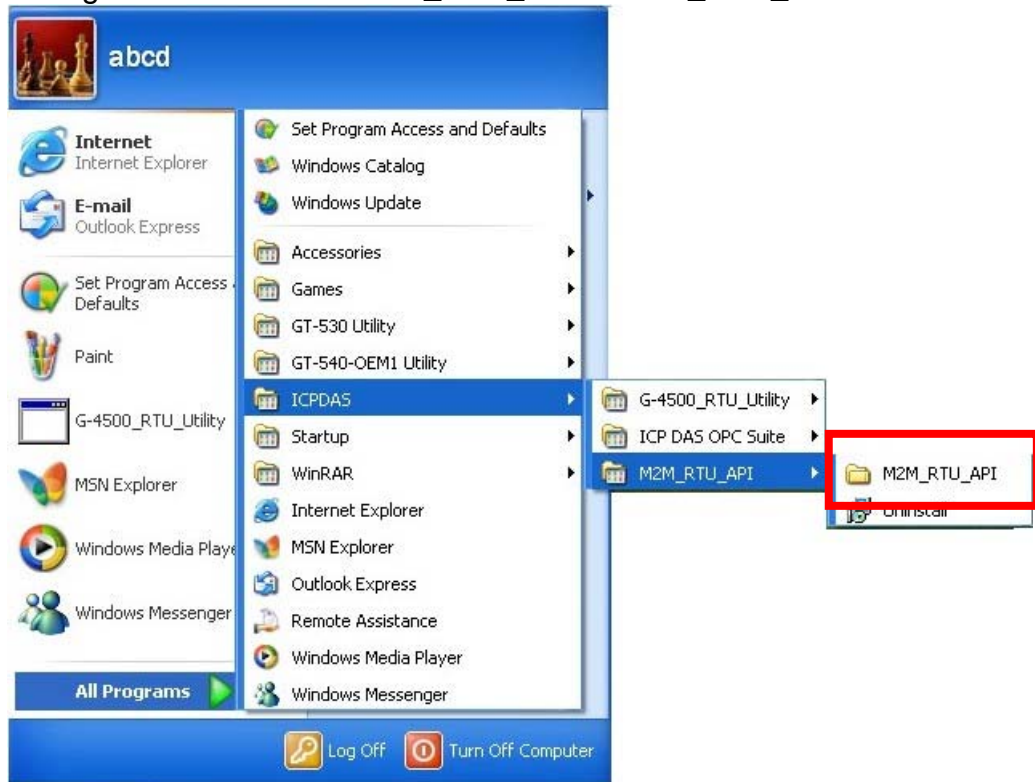

## 4. Function Description

### *DLL Function Definition and Description*

All the functions provided in the M2M\_RTU.dll are listed in the following table and detail information for every function is presented in the next sub-section. However, in order to make the descriptions more simply and clear, the attributes for the both the input and output parameter functions are given as **[input]** and **[output]** respectively, as shown in the following table.

| Keyword  | Set parameter by user before calling this function | Get the data from this parameter after calling this function |
|----------|--|--|
| [input]  | Yes  | No   |
| [output] | No   | Yes  |

### Functions Table

| No. | Function Name              | Description   |
|-----|----------------------------|---|
| 1   | GET_Total_Station_NUM      | Get the number of M2M RTU devices connecting to M2M RTU Center.                 |
| 2   | GET_StationID_Total_Info   | Get the information of total RTU stations from system M2M RTU Center.           |
| 3   | GET_Modbus_DO              | Get the DO status of the specified Modbus device of RTU devices.                |
| 4   | GET_Modbus_DI              | Get the DI status of the specified Modbus device of the RTU devices.            |
| 5   | GET_Modbus_DO_Channel      | Get the DO number of the specified Modbus device connecting the RTU devices.    |
| 6   | GET_Modbus_DI_Channel      | Get the DI number of the specified Modbus device connecting the RTU devices.    |
| 7   | GET_Modbus_AO_Channel      | Get the AO number of the specified Modbus device connecting the RTU devices.    |
| 8   | GET_Modbus_AI_Channel      | Get the AI number of the specified Modbus device connecting the RTU devices.    |
| 9   | GET_Modbus_Counter_Channel | Get the AI number of the specified Modbus device connecting the RTU devices.    |
| 10  | GET_Modbus_GPS             | Get the AI number of the specified Modbus device connecting the RTU devices.    |
| 11  | WRITE_Modbus_DO_Channel    | Write the DO channel of the specified Modbus device connecting the RTU devices. |
| 12  | WRITE_Modbus_AO_Channel    | Write the DO channel of the specified Modbus device connecting the RTU devices. |
| 13  | WRITE_Modbus_DO            | Write the DO total channels Modbus device connecting the RTU devices.           |
| 14  | RTU_WakeUpAP               | Open M2M RTU Center software  |

|    |               |   |
|----|---------------|---|
| 15 | RTU_CloseAP   | Close M2M RTU Center software                   |
| 16 | Get_RTUWDT    | Return the WDT value of the specified GPRS RTU. |
| 17 | GetDllVersion | Get the version of this DLL.                    |
| 18 | GetDllDate    | Get the date of this DLL                        |
| 19 | GET_DateTime  | Get data and time of last package               |

## Structure definition

```
struct OPC_Total_Info
```

```
{
    unsigned int iStationID;
    unsigned int iModbus_Num;
    unsigned int iModule;
    unsigned char cModule_Name[40];
    unsigned int uiModule_Name_Len;
    char Modbus_Module_Name[MODBUS_DEVICE_MAX_SIZE][24];
    BYTE Slave_ID[MODBUS_DEVICE_MAX_SIZE];
    BYTE DI_Num[MODBUS_DEVICE_MAX_SIZE];
    BYTE DO_Num[MODBUS_DEVICE_MAX_SIZE];
    BYTE AI_Num[MODBUS_DEVICE_MAX_SIZE];
    BYTE AO_Num[MODBUS_DEVICE_MAX_SIZE];
    BYTE Counter_Num[MODBUS_DEVICE_MAX_SIZE];
    BYTE bEnGPS[MODBUS_DEVICE_MAX_SIZE];
}
```

Return code of function

```
#define _NOERROR 0
#define _ERROR -1 //
#define _CON_FAILED 1 //Connection is fail
#define _MB_DATA_FAILED 2 //Modbus data is fail.
#define _INIT_FAILED 3 //Initial is fail.
#define _STATIONID_OR_SLAVEID_ERR 4 //can't find the match StationID or
SlaveID

#define STATION_NUM_MAX_SIZE 128 //support max. Station number
#define MODBUS_DEVICE_MAX_SIZE 11 //One station supports max. Modbus
devices.
```

#### 4.1 GET\_Total\_Station\_NUM

**Description:**

This function is used to get the number of M2M RTU devices connecting to M2M RTU Center.

**Syntax:**

```
int GET_Total_Station_NUM(unsigned int *iStation_Num);
```

**Parameter:**

iStation\_Num: [output] The total number of GPRS RTU devices connecting to M2M RTU Center.

**Return:**

0: No Error  
3: Initial Failed

**Example:**

```
unsigned Int iStation_Num = 0;  
GET_Total_Station_NUM(&iStation_Num);  
Print("The total station number are %d.", iSatation_Num);
```

## 4.2 GET\_StationID\_Total\_Info

### Description:

This function is used to get the information of the defined M2M RTU device connecting to M2M RTU Center.

### Syntax:

```
int GET_StationID_Total_Info(unsigned int iNum, struct OPC_Total_Info
*StationID_Total_Info)
```

### Parameter:

iNum: [input] The total number of GPRS RTU devices connecting to M2M RTU Center.

StationID\_Total\_Info: [output] The information of the specified GPRS RTU device.

```
struct OPC_Total_Info
{
    unsigned int iStationID;
    unsigned int iModbus_Num;
    unsigned int iModule;.
    char Modbus_Module_Name[MODBUS_DEVICE_MAX_SIZE][24];
    BYTE Slave_ID[MODBUS_DEVICE_MAX_SIZE];
    BYTE DI_Num[MODBUS_DEVICE_MAX_SIZE];
    BYTE DO_Num[MODBUS_DEVICE_MAX_SIZE];
    BYTE AI_Num[MODBUS_DEVICE_MAX_SIZE];
    BYTE AO_Num[MODBUS_DEVICE_MAX_SIZE];
    BYTE Counter_Num[MODBUS_DEVICE_MAX_SIZE];
    BYTE bEnGPS[MODBUS_DEVICE_MAX_SIZE];
};
```

| Item                                | Description                                |  |
|-------------------------------------|--|--|
| iStationID                          | The Station ID of module                   |  |
| iModbus_Num                         | The total number of Modbus of module       |  |
| Slave_ID[MODBUS_DEVICE_MAX_SIZE];   | The slave ID of assign modbus device       |  |
| DI_Num[MODBUS_DEVICE_MAX_SIZE]      | The DI number of assign modbus device      |  |
| DO_Num[MODBUS_DEVICE_MAX_SIZE];     | The DO number of assign modbus device      |  |
| AI_Num[MODBUS_DEVICE_MAX_SIZE]      | The AI number of assign modbus device      |  |
| AO_Num[MODBUS_DEVICE_MAX_SIZE]      | The AO number of assign modbus device      |  |
| Counter_Num[MODBUS_DEVICE_MAX_SIZE] | The Counter number of assign modbus device |  |
| bEnGPS[MODBUS_DEVICE_MAX_SIZE]      | The GPS number of assign modbus device     |  |

**Return:**

0: No Error  
 1: don't establish the connection  
 2: Modbus Data are invalid  
 4: Station ID or Modbus Slave ID is invalid.

**Example:**

```

unsigned int iStation_Num = 0;
unsigned int i = 0;
unsigned int j = 0;
struct OPC_Total_Info opc_total_info;

GET_Total_Station_NUM(&iStation_Num);
Print("The total station number are %d.\r\n", iSatation_Num);

for(i=0; i< iStation_Num; i++)
{
  GET_StationID_Total_Info(i, & opc_total_info);
  Print("StationID=%d\r\n", opc_total_info. iStationID);
  Print("The total number of Modbus of module=%d\r\n", opc_total_info. iModbus_Num);

  for(j=0; j< opc_total_info. iModbus_Num; j++)
  {
    Print("Slave_ID=%d\r\n", opc_total_info. Slave_ID[j]);
    Print(" DI_Num=%d\r\n", opc_total_info.DI_Num[j]);
    Print(" DO_Num=%d\r\n", opc_total_info.DO_Num[j]);
    Print(" AI_Num=%d\r\n", opc_total_info.AI_Num[j]);
    Print(" AO_Num=%d\r\n", opc_total_info.AO_Num[j]);
    Print(" Counter_Num=%d\r\n", opc_total_info. Counter_Num [j]);
    Print(" bEnGPS =%d\r\n", opc_total_info. bEnGPS [j]);
  }
}

```

**Note: If the Slave ID is 255, it represents the local IO of G-4500 or GT-540.**



### 4.3 GET\_Modbus\_DO

**Description:**

This function is used to get the DO value of the defined Modbus RTU in M2M RTU connecting to M2M RTU Center.

**Syntax:**

```
int GET_Modbus_DO(unsigned int iStationID, BYTE *bModbus_Module_Name, BYTE bModbus_SlaveID, unsigned long *Value);
```

**Parameter:**

bModbus\_Module\_Name: [input]  
iStationID: [input]  
bModbus\_SlaveID: [input]  
Value: [output]

**Return:**

0: No Error  
1: don't establish the connection  
2: Modbus Data are invalid  
4: Station ID or Modbus Slave ID is invalid.

**Example:**

```
unsigned int iStationID = 1; //StationID: 1  
BYTE bModbus_Module_Name[] = "Local IO";  
BYTE bModbus_SlaveID = 255; //local IO  
unsigned long Value = 0;
```

```
GET_Modbus_DO(iStationID, bModbus_Module_Name, bModbus_SlaveID, &Value);  
Print("StationID:1,SlaveID:255(local total DO)=%lu\r\n", Value);
```

**Note: If the Slave ID is 255, it represents the local IO of G-4500 or GT-540.**

## 4.4 GET\_Modbus\_DI

### Description:

This function is used to get the DI value of the defined the Modbus RTU devices in M2M RTU connecting to M2M RTU Center.

### Syntax:

```
int GET_Modbus_DI(unsigned int iStationID, BYTE *bModbus_Module_Name, BYTE bModbus_SlaveID, unsigned long *Value);
```

### Parameter:

iStationID: [input]  
bModbus\_Module\_Name: [input]  
bModbus\_SlaveID: [input]  
Value: [output]

### Return:

0: No Error  
1: don't establish the connection  
2: Modbus Data are invalid  
4: Station ID or Modbus Slave ID is invalid.

### Example:

```
unsigned int iStationID = 1; //StationID: 1  
BYTE bModbus_Module_Name[] = "Local IO";  
BYTE bModbus_SlaveID = 255; //local IO  
unsigned long Value = 0;
```

```
GET_Modbus_DI(iStationID, bModbus_Module_Name, bModbus_SlaveID, &Value);  
Print("StationID:1,SlaveID:255(local total DI)=%lu\r\n", Value);
```

**Note: If the Slave ID is 255, it represents the local IO of G-4500 or GT-540.**

## 4.5 GET\_Modbus\_DO\_Channel

### Description:

This function is used to get the specified DO channel value of the defined Modbus RTU devices in M2M RTU connecting to M2M RTU Center.

### Syntax:

```
int GET_Modbus_DO_Channel(unsigned int iStationID, BYTE *bModbus_Module_Name,
BYTE bModbus_SlaveID, BYTE channel, BYTE *Value);
```

### Parameter:

iStationID: [input]  
bModbus\_Module\_Name: [input]  
bModbus\_SlaveID: [input]  
channel: [input]  
Value: [output]

### Return:

0: No Error  
1: don't establish the connection  
2: Modbus Data are invalid  
4: Station ID or Modbus Slave ID is invalid.

### Example:

```
unsigned int iStationID = 1; //StationID: 1
BYTE bModbus_Module_Name[] = "Local IO";
BYTE bModbus_SlaveID = 255; //local DO
BYTE channel = 1; //Ch1 of local DO
BYTE Value = 0;
```

```
GET_Modbus_DO_Channel(iStationID, bModbus_Module_Name, bModbus_SlaveID,
channel, &Value);
Print("StationID:1,SlaveID:255(local DO ch1)=%d\r\n", Value);
```

**Note: If the Slave ID is 255, it represents the local IO of G-4500 or GT-540.**

## 4.6 GET\_Modbus\_DI\_Channel

### Description:

This function is used to get the specified DI channel value of the defined Modbus RTU in M2M RTU connecting to M2M RTU Center.

### Syntax:

```
int GET_Modbus_DI_Channel(unsigned int iStationID, BYTE *bModbus_Module_Name,
BYTE bModbus_SlaveID, BYTE channel, BYTE *Value);
```

### Parameter:

iStationID: [input]  
bModbus\_Module\_Name: [input]  
bModbus\_SlaveID: [input]  
channel: [input]  
Value: [output]

### Return:

0: No Error  
1: don't establish the connection  
2: Modbus Data are invalid  
4: Station ID or Modbus Slave ID is invalid.

### Example:

```
unsigned int iStationID = 1; //StationID: 1
BYTE bModbus_Module_Name[] = "Local IO";
BYTE bModbus_SlaveID = 255; //local DO
BYTE channel = 0; //Ch1 of local DO
BYTE Value = 0;
```

```
GET_Modbus_DI_Channel(iStationID, bModbus_Module_Name, bModbus_SlaveID,
channel, &Value);
Print("StationID:1,SlaveID:255(local DI ch0)=%d\r\n", Value);
```

**Note: If the Slave ID is 255, it represents the local IO of G-4500 or GT-540.**

## 4.7 GET\_Modbus\_AO\_Channel

### Description:

This function is used to get the specified AO channel value of the defined Modbus RTU in M2M RTU connecting to M2M RTU Center.

### Syntax:

```
int GET_Modbus_AO_Channel(unsigned int iStationID, BYTE *bModbus_Module_Name,
BYTE bModbus_SlaveID, BYTE channel, BYTE *DataFormat, BYTE *Type, unsigned short
*Value);
```

### Parameter:

iStationID: [input]  
bModbus\_Module\_Name: [input]  
bModbus\_SlaveID: [input]  
channel: [input]  
DataFormat: [output]  
Value: [output]

### Return:

0: No Error  
1: don't establish the connection  
2: Modbus Data are invalid  
4: Station ID or Modbus Slave ID is invalid.

### Example:

```
unsigned int iStationID = 1; //StationID: 1
BYTE bModbus_Module_Name[] = "Local IO";
BYTE bModbus_SlaveID = 255; //local AO
BYTE channel = 1; //Ch1 of local AO
BYTE DataFormat;
BYTE Type;
unsigned short Value = 0;
```

```
GET_Modbus_AO_Channel(iStationID, bModbus_Module_Name, bModbus_SlaveID,
channel, &DataFormat, &Type, &Value);
Print("StationID:1,SlaveID:255(local AO ch1)=%d\r\n", Value);
```

**Note: If the Slave ID is 255, it represents the local IO of G-4500 or GT-540.**

## 4.8 GET\_Modbus\_AI\_Channel

### Description:

This function is used to get the specified AI channel value of the defined Modbus RTU in M2M RTU connecting to M2M RTU Center.

### Syntax:

```
int GET_Modbus_AI_Channel(unsigned int iStationID, BYTE *bModbus_Module_Name,
BYTE bModbus_SlaveID, BYTE channel, BYTE *DataFormat, BYTE *Type, unsigned short
*Value);
```

### Parameter:

iStationID: [input]  
bModbus\_Module\_Name: [input]  
bModbus\_SlaveID: [input]  
channel: [input]  
DataFormat: [output]  
Value: [output]

### Return:

0: No Error  
1: don't establish the connection  
2: Modbus Data are invalid  
4: Station ID or Modbus Slave ID is invalid.

### Example:

```
unsigned int iStationID = 1; //StationID: 1
BYTE bModbus_Module_Name[] = "Local IO";
BYTE bModbus_SlaveID = 255; //local AI
BYTE channel = 0; //Ch0 of local AI
BYTE DataFormat;
BYTE Type;
unsigned short Value = 0;
```

```
GET_Modbus_AI_Channel(iStationID, bModbus_Module_Name, bModbus_SlaveID,
channel, &DataFormat, &Type, &Value);
Print("StationID:1,SlaveID:255(local AI ch0)=%d\r\n", Value);
```

**Note: If the Slave ID is 255, it represents the local IO of G-4500 or GT-540.**

## 4.9 GET\_Modbus\_Counter\_Channel

### Description:

This function is used to get the specified counter channel value of the defined Modbus RTU in M2M RTU connecting to M2M RTU Center.

### Syntax:

```
int GET_Modbus_Counter_Channel(unsigned int iStationID, BYTE
*bModbus_Module_Name, BYTE bModbus_SlaveID, BYTE channel, unsigned int *Value);
```

### Parameter:

iStationID: [input]  
bModbus\_Module\_Name: [input]  
bModbus\_SlaveID: [input]  
channel: [input]  
Value: [output]

### Return:

0: No Error  
1: don't establish the connection  
2: Modbus Data are invalid  
4: Station ID or Modbus Slave ID is invalid.

### Example:

```
unsigned int iStationID = 1; //StationID: 1
BYTE bModbus_Module_Name[] = "Local IO";
BYTE bModbus_SlaveID = 255; //local Counter
BYTE channel = 0; //Ch0 of local Counter
unsigned int Value = 0;
```

```
GET_Modbus_Counter_Channel(iStationID, bModbus_Module_Name, bModbus_SlaveID,
channel, &Value);
Print("StationID:1,SlaveID:255(local Counter ch0)=%lu\r\n", Value);
```

**Note: If the Slave ID is 255, it represents the local IO of G-4500 or GT-540.**

## 4.10 GET\_Modbus\_GPS

### Description:

This function is used to get the GPS information of the M2M RTU connecting to M2M RTU Center.

### Syntax:

```
int GET_Modbus_GPS(unsigned int iStationID, BYTE *bModbus_Module_Name, BYTE bModbus_SlaveID, char *Value);
```

### Parameter:

iStationID: [input]  
bModbus\_Module\_Name: [input]  
bModbus\_SlaveID: [input]  
Value: [output]

### Return:

0: No Error  
1: don't establish the connection  
2: Modbus Data are invalid  
4: Station ID or Modbus Slave ID is invalid  
5: Module didn't enable GPS function

### Example:

```
unsigned int iStationID = 1; //StationID: 1  
BYTE bModbus_Module_Name[] = "Local IO";  
BYTE bModbus_SlaveID = 255; //local Counter  
char Value[255];
```

```
GET_Modbus_GPS(iStationID, bModbus_Module_Name, bModbus_SlaveID, Value);  
Print("StationID:1,SlaveID:255(local GPS)=%s\r\n", Value);
```

**Note: If the Slave ID is 255, it represents the local IO of G-4500 or GT-540.**



## 4.11 WRITE\_Modbus\_DO\_Channel

### Description:

This function is used to set the specified DO channel value of the defined Modbus RTU in M2M RTU connecting to M2M RTU Center.

### Syntax:

```
int WRITE_Modbus_DO_Channel(unsigned int iStationID, BYTE *bModbus_Module_Name,
BYTE bModbus_SlaveID, BYTE bChannel, BYTE bValue);
```

### Parameter:

iStationID: [input]  
bModbus\_Module\_Name: [input]  
bModbus\_SlaveID: [input]  
bChannel: [input]  
Value: [output]

### Return:

0: No Error  
1: don't establish the connection  
2: Modbus Data are invalid  
4: Station ID or Modbus Slave ID is invalid.

### Example:

```
unsigned int iStationID = 1; //StationID: 1
BYTE bModbus_Module_Name[] = "Local IO";
BYTE bModbus_SlaveID = 255; //local Counter
BYTE bChannel = 0;
BYTE Value = 1;
int iRet = 0;
```

```
iRet = WRITE_Modbus_DO_Channel(iStationID, bModbus_Module_Name,
bModbus_SlaveID, bChannel, Value);
Print("WRITE_Modbus_DO_Channel(StationID:1,SlaveID:255)(local DO ch0)=%d\r\n",
iRet);
```

**Note: If the Slave ID is 255, it represents the local IO of G-4500 or GT-540.**

## 4.12 WRITE\_Modbus\_AO\_Channel

### Description:

This function is used to set the specified AO channel value of the defined Modbus RTU in M2M RTU connecting to M2M RTU Center.

### Syntax:

```
int WRITE_Modbus_AO_Channel(unsigned int iStationID, BYTE *bModbus_Module_Name,
BYTE bModbus_SlaveID, BYTE bChannel, unsigned short usValue);
```

### Parameter:

iStationID: [input]  
bModbus\_Module\_Name: [input]  
bModbus\_SlaveID: [input]  
bChannel: [input]  
usValue: [output]

### Return:

0: No Error  
1: don't establish the connection  
2: Modbus Data are invalid  
4: Station ID or Modbus Slave ID is invalid.

### Example:

```
unsigned int iStationID = 1; //StationID: 1
BYTE bModbus_Module_Name[] = "Local IO";
BYTE bModbus_SlaveID = 255; //local Counter
BYTE bChannel = 0;
unsigned short Value = 1;
int iRet = 0;
```

```
iRet = WRITE_Modbus_AO_Channel(iStationID, bModbus_Module_Name,
bModbus_SlaveID, bChannel, Value);
Print("WRITE_Modbus_AO_Channel(StationID:1,SlaveID:255)(local AO ch0)=%d\r\n",
iRet);
```

**Note: If the Slave ID is 255, it represents the local IO of G-4500 or GT-540.**

### 4.13 WRITE\_Modbus\_DO

**Description:**

This function is used to set the specified DO value of the defined Modbus RTU in M2M RTU connecting to M2M RTU Center.

**Syntax:**

```
int WRITE_Modbus_DO(unsigned int iStationID, BYTE *bModbus_Module_Name, BYTE bModbus_SlaveID, unsigned long ulValue);
```

**Parameter:**

iStationID: [input]  
bModbus\_Module\_Name: [input]  
bModbus\_SlaveID: [input]  
bChannel: [input]  
usValue: [output]

**Return:**

0: No Error  
1: don't establish the connection  
2: Modbus Data are invalid  
4: Station ID or Modbus Slave ID is invalid.

**Example:**

```
unsigned int iStationID = 1; //StationID: 1  
BYTE bModbus_Module_Name[] = "Local IO";  
BYTE bModbus_SlaveID = 255; //local Counter  
BYTE bChannel = 0;  
unsigned long Value = 7;  
int iRet = 0;
```

```
iRet = WRITE_Modbus_DO(iStationID, bModbus_Module_Name, bModbus_SlaveID,  
Value);  
Print("WRITE_Modbus_DO(StationID:1,SlaveID:255)(total local DO)=%d\r\n", iRet);
```

**Note: If the Slave ID is 255, it represents the local IO of G-4500 or GT-540.**

#### 4.14 RTU\_WakeUpAP

**Description:**

This function is used to open M2M RTU Center software.

**Syntax:**

```
int RTU_WakeUpAP(BYTE bMethod);
```

**Parameter:**

bMethod: [input]

0: from OPC Server

1: from Other Server

**Return:**

0: No Error

**Example:**

```
BYTE bMethod = 1;  
RTU_WakeUpAP(1);
```

## 4.15 RTU\_CloseAP

### **Description:**

This function is used to close M2M RTU Center software.

### **Syntax:**

```
int RTU_CloseAP(void);
```

### **Parameter:**

### **Return:**

0: No Error

### **Example:**

```
RTU_CloseAP();
```

## 4.16 Get\_RTUWDT

### **Description:**

This function is used to get the WDT value of M2M RTU Center. The M2M RTU Center will add 1 every second. If the Get\_RTUWDT function doesn't receive add 1 every second, please restart the M2M RTU Center software.

### **Syntax:**

```
unsigned int Get_RTUWDT(void);
```

### **Parameter:**

### **Return:**

0: No Error

### **Example:**

```
Get_RTUWDT ();
```

## 4.17 GetDllVersion

### Description:

This function is used to get the Dll version of API.

### Syntax:

```
unsigned int GetDllVersion(void);
```

### Parameter:

### Return:

0: No Error

### Example:

```
int iLib = 0;  
iLib = GetDllVersion();  
Print("GPRS_RTU.dll version %X.%02X\r\n", iLib>>8, iLib&0xff);
```

#### 4.18 GetDIIDate

**Description:**

This function is used to get the DII date of API.

**Syntax:**

```
void GetDIIDate(char *cDate);
```

**Parameter:**

**Return:**

0: No Error

**Example:**

```
char cDate[20];  
GetDIIDate(cDate);  
Print("GPRS_RTU.dll date:%s\r\n", cDate);
```



---

## 4.19 GET\_DateTime

**Description:**

This function is used to get last package date and time.

**Syntax:**

```
Int GET_DateTime(unsigned int iStationID, int *iYear, int *iMonth, int *iDay, int *iHour, int *iMinute, int *iSec);
```

**Parameter:**

iStationID: [input]

iYear: [output]

iMonth: [output]

iDay: [output]

iHour: [output]

iMinute: [output]

iSec: [output]

**Return:**

0: No Error

1: don't establish the connection

4: Station ID is invalid.

**Example:**

```
unsigned int iStationID = 1; //StationID: 1
```

```
int iYear = 0;
```

```
int iMonth = 0;
```

```
int iDay = 0;
```

```
int iHour = 0;
```

```
int iMinute = 0;
```

```
int iSec = 0;
```

```
GET_DateTime(iStationID, &iYear, &iMonth, &iDay, &iHour, &iMinute, &iSec);
```

```
Print("Year=%d\r\nMonth=%d\r\nDay=%d\r\nHour=%d\r\nMinute=%d\r\nSec=%d\r\n", iYear, iMonth, iDay, iHour, iMinute, iSec);
```

## 5. Data format definiens

| Data format | Description       |
|-------------|-------------------|
| 0           | engineering unit. |
| 1           | 2's complement    |
| 2           | hexadecimal       |
| 3           | % of FSR          |
| 254         | Counter hex       |
| 255         | Unknown           |

## 6. Type code definiens

AI Type code

| AI Type Code | Input Type      | Data Format      | +F.S     | -F.S.    |
|--------------|-----------------|------------------|----------|----------|
| 00           | -15 to +15 mV   | Engineering unit | +15.000  | -15.000  |
|              |                 | % of FSR         | +100.00  | -100.00  |
|              |                 | 2's comp HEX     | 7FFF     | 8000     |
| 01           | -50 to +50 mV   | Engineering unit | +50.000  | -50.000  |
|              |                 | % of FSR         | +100.00  | -100.00  |
|              |                 | 2's comp HEX     | 7FFF     | 8000     |
| 02           | -100 to +100 mV | Engineering unit | +100.000 | -100.000 |
|              |                 | % of FSR         | +100.00  | -100.00  |
|              |                 | 2's comp HEX     | 7FFF     | 8000     |
| 03           | -500 to +500 mV | Engineering unit | +500.00  | -500.00  |
|              |                 | % of FSR         | +100.00  | -100.00  |
|              |                 | 2's comp HEX     | 7FFF     | 8000     |
| 04           | -1 to +1 V      | Engineering unit | +1.0000  | -1.0000  |
|              |                 | % of FSR         | +100.00  | -100.00  |
|              |                 | 2's comp HEX     | 7FFF     | 8000     |
| 05           | -2.5 to +2.5 V  | Engineering unit | +2.5000  | -2.5000  |
|              |                 | % of FSR         | +100.00  | -100.00  |
|              |                 | 2's comp HEX     | 7FFF     | 8000     |
| 06           | -20 to +20 mA   | Engineering unit | +20.000  | -20.000  |
|              |                 | % of FSR         | +100.00  | -100.00  |
|              |                 | 2's comp HEX     | 7FFF     | 8000     |
| 07           | 4 to 20 mA      | Engineering unit | +20.000  | +04.000  |
|              |                 | % of FSR         | +100.00  | -100.00  |
|              |                 | 2's comp HEX     | 7FFF     | 8000     |
| 08           | -10 to +10 V    | Engineering unit | +10.000  | -10.000  |
|              |                 | % of FSR         | +100.00  | -100.00  |
|              |                 | 2's comp HEX     | 7FFF     | 8000     |
| 09           | -5 to +5 V      | Engineering unit | +5.0000  | -5.0000  |
|              |                 | % of FSR         | +100.00  | -100.00  |
|              |                 | 2's comp HEX     | 7FFF     | 8000     |
| 10           | -1 to +1 V      | Engineering unit | +1.0000  | -1.0000  |
|              |                 | % of FSR         | +100.00  | -100.00  |
|              |                 | 2's comp HEX     | 7FFF     | 8000     |

|    |                    |                  |         |          |
|----|--------------------|------------------|---------|----------|
| 11 | -500 to +500<br>mV | Engineering unit | +500.00 | -500.00  |
|    |                    | % of FSR         | +100.00 | -100.00  |
|    |                    | 2's comp HEX     | 7FFF    | 8000     |
| 12 | -150 to +150<br>mV | Engineering unit | +150.00 | -150.00  |
|    |                    | % of FSR         | +100.00 | -100.00  |
|    |                    | 2's comp HEX     | 7FFF    | 8000     |
| 13 | -20 to +20 mA      | Engineering unit | +20.000 | -20.000  |
|    |                    | % of FSR         | +100.00 | -100.00  |
|    |                    | 2's comp HEX     | 7FFF    | 8000     |
| 14 | -210 to 760 °C     | Engineering unit | +760.00 | -210.00  |
|    |                    | % of FSR         | +100.00 | -027.63  |
|    |                    | 2's comp HEX     | 7FFF    | DCA2     |
| 15 | -270 to 1372 °C    | Engineering unit | +1372.0 | -0270.0  |
|    |                    | % of FSR         | +100.00 | -019.68  |
|    |                    | 2's comp HEX     | 7FFF    | E6D0     |
| 16 | -270 to 400 °C     | Engineering unit | +400.00 | -270.00  |
|    |                    | % of FSR         | +100.00 | -067.5   |
|    |                    | 2's comp HEX     | 7FFF    | A99A     |
| 17 | -270 to 1000 °C    | Engineering unit | +1000.0 | -0270.0  |
|    |                    | % of FSR         | +100.00 | -027.00  |
|    |                    | 2's comp HEX     | 7FFF    | DD71     |
| 18 | 0 to 1768 °C       | Engineering unit | +1768.0 | +0000.0  |
|    |                    | % of FSR         | +100.00 | +000.00  |
|    |                    | 2's comp HEX     | 7FFF    | 0000     |
| 19 | 0 to 1768 °C       | Engineering unit | +1768.0 | +0000.0  |
|    |                    | % of FSR         | +100.00 | +000.00  |
|    |                    | 2's comp HEX     | 7FFF    | 0000     |
| 20 | 0 to 1802 °C       | Engineering unit | +1820.0 | +0000.0  |
|    |                    | % of FSR         | +100.00 | +000.00  |
|    |                    | 2's comp HEX     | 7FFF    | 0000     |
| 21 | -270 to 1300 °C    | Engineering unit | +1300.0 | -0270.00 |
|    |                    | % of FSR         | +100.00 | -020.77  |
|    |                    | 2's comp HEX     | 7FFF    | E56B     |
| 22 | 0 to 2320 °C       | Engineering unit | +2320.0 | +0000.0  |
|    |                    | % of FSR         | +100.00 | +000.00  |
|    |                    | 2's comp HEX     | 7FFF    | 0000     |
| 23 | -200 to 800 °C     | Engineering unit | +800.00 | -200.00  |
|    |                    | % of FSR         | +100.00 | -025.00  |
|    |                    | 2's comp HEX     | 7FFF    | E000     |

|    |                |                  |         |         |
|----|----------------|------------------|---------|---------|
| 24 | -200 to 100 °C | Engineering unit | +100.00 | -200.00 |
|    |                | % of FSR         | +050.00 | -100.00 |
|    |                | 2's comp HEX     | 4000    | 8000    |
| 25 | -200 to 900 °C | Engineering unit | +900.00 | -200.00 |
|    |                | % of FSR         | +100.00 | -022.22 |
|    |                | 2's comp HEX     | 7FFF    | E38E    |
| 26 | 0 to 20 mA     | Engineering unit | +20.000 | +00.000 |
|    |                | % of FSR         | +100.00 | +000.00 |
|    |                | 2's comp HEX     | FFFF    | 0000    |
| 27 | -150 to +150 V | Engineering unit | +150.00 | -150.00 |
|    |                | % of FSR         | +100.00 | -100.00 |
|    |                | 2's comp HEX     | 7FFF    | 8000    |
| 28 | -50 to +50 V   | Engineering unit | +50.000 | -50.000 |
|    |                | % of FSR         | +100.00 | -100.00 |
|    |                | 2's comp HEX     | 7FFF    | 8000    |
| 32 | -100 to 100 °C | Engineering unit | +100.00 | -100.00 |
|    |                | % of FSR         | +100.00 | -100.00 |
|    |                | 2's comp HEX     | 7FFF    | 8000    |
| 33 | 0 to 100 °C    | Engineering unit | +100.00 | -100.00 |
|    |                | % of FSR         | +100.00 | -100.00 |
|    |                | 2's comp HEX     | 7FFF    | 0000    |
| 34 | 0 to 200 °C    | Engineering unit | +200.00 | +000.00 |
|    |                | % of FSR         | +100.00 | +000.00 |
|    |                | 2's comp HEX     | 7FFF    | 0000    |
| 35 | 0 to 600 °C    | Engineering unit | +600.00 | +000.00 |
|    |                | % of FSR         | +100.00 | +000.00 |
|    |                | 2's comp HEX     | 7FFF    | 0000    |
| 36 | -100 to 100 °C | Engineering unit | +100.00 | -100.00 |
|    |                | % of FSR         | +100.00 | -100.00 |
|    |                | 2's comp HEX     | 7FFF    | 8000    |
| 37 | 0 to 100 °C    | Engineering unit | +100.00 | +000.00 |
|    |                | % of FSR         | +100.00 | +000.00 |
|    |                | 2's comp HEX     | 7FFF    | 0000    |
| 38 | 0 to 200 °C    | Engineering unit | +200.00 | +000.00 |
|    |                | % of FSR         | +100.00 | +000.00 |
|    |                | 2's comp HEX     | 7FFF    | 0000    |
| 39 | 0 to 600 °C    | Engineering unit | +600.00 | +000.00 |
|    |                | % of FSR         | +100.00 | +000.00 |

|     |                |                  |         |         |
|-----|----------------|------------------|---------|---------|
|     |                | 2's comp HEX     | 7FFF    | 0000    |
| 40  | -80 to 100 °C  | Engineering unit | +100.00 | -080.00 |
|     |                | % of FSR         | +100.00 | -080.00 |
|     |                | 2's comp HEX     | 7FFF    | 999A    |
| 41  | 0 to 100 °C    | Engineering unit | +100.00 | +000.00 |
|     |                | % of FSR         | +100.00 | +000.00 |
|     |                | 2's comp HEX     | 7FFF    | 0000    |
| 42  | -200 to 600 °C | Engineering unit | +600.00 | -200.00 |
|     |                | % of FSR         | +100.00 | -033.33 |
|     |                | 2's comp HEX     | 7FFF    | D556    |
| 43  | -20 to 150 °C  | Engineering unit | +150.00 | -020.00 |
|     |                | % of FSR         | +100.00 | -013.33 |
|     |                | 2's comp HEX     | 7FFF    | EEEE    |
| 44  | 0 to 200 °C    | Engineering unit | +200.00 | +000.00 |
|     |                | % of FSR         | +100.00 | +000.00 |
|     |                | 2's comp HEX     | 7FFF    | 0000    |
| 45  | -20 to 150 °C  | Engineering unit | +150.00 | -020.00 |
|     |                | % of FSR         | +100.00 | -013.33 |
|     |                | 2's comp HEX     | 7FFF    | EEEE    |
| 46  | -200 to 200 °C | Engineering unit | +200.00 | -200.00 |
|     |                | % of FSR         | +100.00 | -100.00 |
|     |                | 2's comp HEX     | 7FFF    | 8000    |
| 47  | -200 to 200 °C | Engineering unit | +200.00 | -200.00 |
|     |                | % of FSR         | +100.00 | -100.00 |
|     |                | 2's comp HEX     | 7FFF    | 8000    |
| 128 | -200 to 600 °C | Engineering unit | +600.00 | -200.00 |
|     |                | % of FSR         | +100.00 | -033.33 |
|     |                | 2's comp HEX     | 7FFF    | D556    |
| 129 | -200 to 600 °C | Engineering unit | +600.00 | -200.00 |
|     |                | % of FSR         | +100.00 | -033.33 |
|     |                | 2's comp HEX     | 7FFF    | D556    |
| 130 | -50 to 150 °C  | Engineering unit | +150.00 | -050.00 |
|     |                | % of FSR         | +100.00 | -033.33 |
|     |                | 2's comp HEX     | 7FFF    | D556    |
| 131 | -60 to 180 °C  | Engineering unit | +180.00 | -060.00 |
|     |                | % of FSR         | +100.00 | -033.33 |
|     |                | 2's comp HEX     | 7FFF    | D556    |

|                   |                    |                 |                    |                    |
|-------------------|--------------------|-----------------|--------------------|--------------------|
| 254<br>(Counter)  | 0 to<br>4294967295 | Counter Value   | Counter Value      | Counter Value      |
| 255<br>(Customer) | 0 to 0             | Customer define | Customer<br>define | Customer<br>define |

## AOType code

| AO Type Code      | Input Type   | Data Format      | +F.S            | -F.S.           |
|-------------------|--------------|------------------|-----------------|-----------------|
| 00                | 0 to 20 mA   | Engineering unit | +20.000         | 00.000          |
|                   |              | % of FSR         | +100.00         | +000.00         |
|                   |              | 2's comp HEX     | FFF             | 0000            |
| 01                | 4 to 20 mA   | Engineering unit | +20.000         | 04.000          |
|                   |              | % of FSR         | +100.00         | +000.00         |
|                   |              | 2's comp HEX     | FFF             | 0000            |
| 02                | 0 to 10 V    | Engineering unit | +10.000         | 00.000          |
|                   |              | % of FSR         | +100.00         | +000.00         |
|                   |              | 2's comp HEX     | FFF             | 0000            |
| 48                | 0 to 20 mA   | Engineering unit | +20.000         | 00.000          |
|                   |              | % of FSR         | +100.00         | +000.00         |
|                   |              | 2's comp HEX     | FFF             | 0000            |
| 49                | 4 to 20 mA   | Engineering unit | +20.000         | 04.000          |
|                   |              | % of FSR         | +100.00         | +000.00         |
|                   |              | 2's comp HEX     | FFF             | 0000            |
| 50                | 0 to 10 V    | Engineering unit | +10.000         | 00.000          |
|                   |              | % of FSR         | +100.00         | +000.00         |
|                   |              | 2's comp HEX     | FFF             | 0000            |
| 51                | -10 to +10 V | Engineering unit | +10.000         | -10.000         |
|                   |              | % of FSR         | +100.00         | +000.00         |
|                   |              | 2's comp HEX     | FFF             | 0000            |
| 52                | 0 to +5V     | Engineering unit | +05.000         | -05.000         |
|                   |              | % of FSR         | +100.00         | +000.00         |
|                   |              | 2's comp HEX     | FFF             | 0000            |
| 53                | -5 to +5V    | Engineering unit | +05.000         | -05.000         |
|                   |              | % of FSR         | +100.00         | +000.00         |
|                   |              | 2's comp HEX     | FFF             | 0000            |
| 255<br>(Customer) | 0 to 0       | Customer define  | Customer define | Customer define |



## History of version

### Revision

| Version | By   | Date       | Description |
|---------|------|------------|-------------|
| 1.00    | Yide | 2010/03/28 |             |
| 1.01    | Yide | 2010/06/02 |             |
| 1.02    | Yide | 2010/08/11 |             |
| 1.03    | Yide | 2011/11/16 |             |
|         |      |            |             |