



TPD-433-M2 Quick Start

v1.1, Jan. 2019

What's in the box?

Thanks for buying ICPDAS TPD-433-M2 device. This shipping package contains the following items:



TPD-433-M2 x 1



Quick Start x 1 (This Document)



Back Piece x 1



Round Head Screws x 2

Related Information

If you are new to TPD-433-M2, please read the “**Chapter 3. Getting Started**” of the **TouchPAD Hardware User Manual** for detailed information about install the free development tool – HMIWorks and how to create your first project.

- Documents, such as the User Manuals, the API References, etc.: <http://ftp.icpdas.com/pub/cd/touchpad/document/>
- Free Development Software, HMIWorks v2.10.10 or above: <http://ftp.icpdas.com/pub/cd/touchpad/setup/>

If you have any questions, please feel free to contact us via email.

1 Appearance

Front View

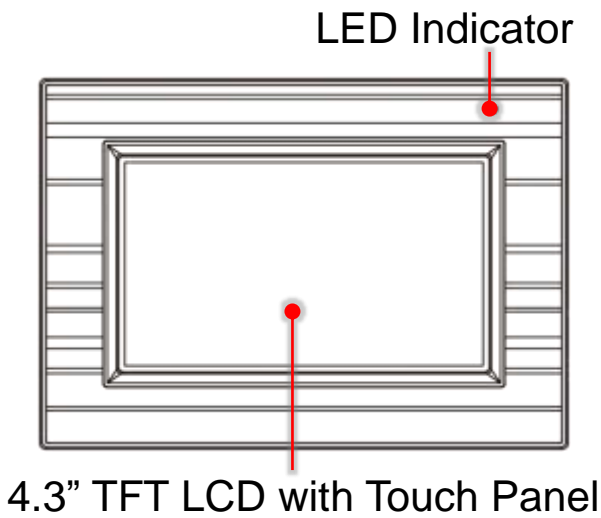

Rear View

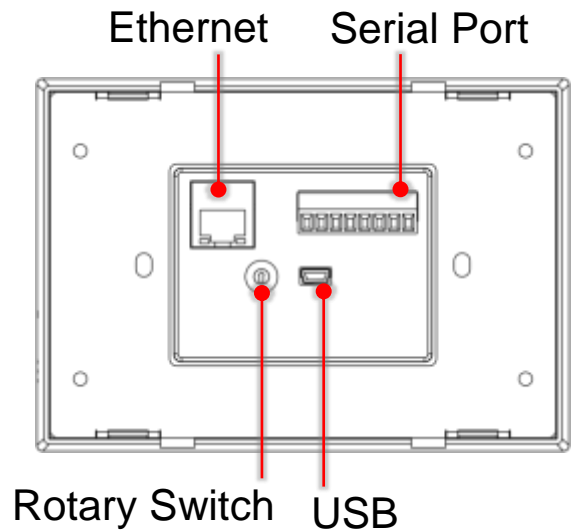

2 Pin Assignments

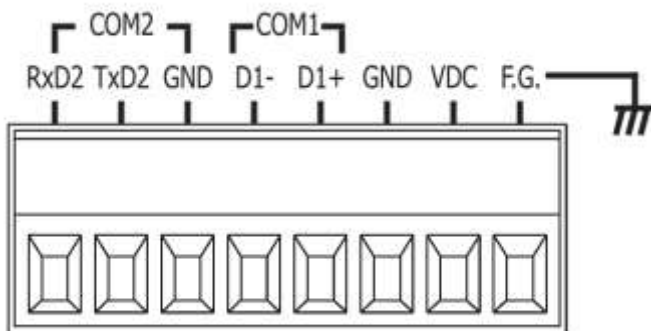

Pin	Description
F.G.	Frame Ground. F.G. is connected to the inside EMI or ESD suppression circuits. Make sure that F.G. is connected to the Earth
VDC	DC input Voltage (range: +12 V ~ +48 V)
GND	Connected to the power supply's ground pin
D1+	The positive data line of the RS-485 network
D1-	The negative data line of the RS-485 network
GND	Ground pin
TxD2	The pin of transmitted data of the RS-232
RxD2	The pin of received data of the RS-232

3

Rotary Switch & Default Settings

The definition of the rotary switch:

	No	Mode	Description
	0	Run & Update (Ethernet)	This is a special run mode which is used in the development stage. The TouchPAD device can be updated by a PC from the remote side through Ethernet. (Default)
	1	Ethernet Force Update	While the application run on the TouchPAD device seriously crashes, use this mode to update a new application to the TouchPAD device through Ethernet.
	2	Run Only	Run the program.
	9	USB Force Update	Update a new application to the TouchPAD device through USB.

Network Default Settings

IP Address	192.168.255.1
Subnet Mask	255.255.0.0
Gateway	192.168.0.1

4

First Use of the TPD-433-M2

1. Connect wires as the below figure or prepare an Ethernet cable which will be used to supply power through PoE if there's a RJ-45 Ethernet port on it. And set the rotary switch to 0 (At this point, the power is not yet supplied).

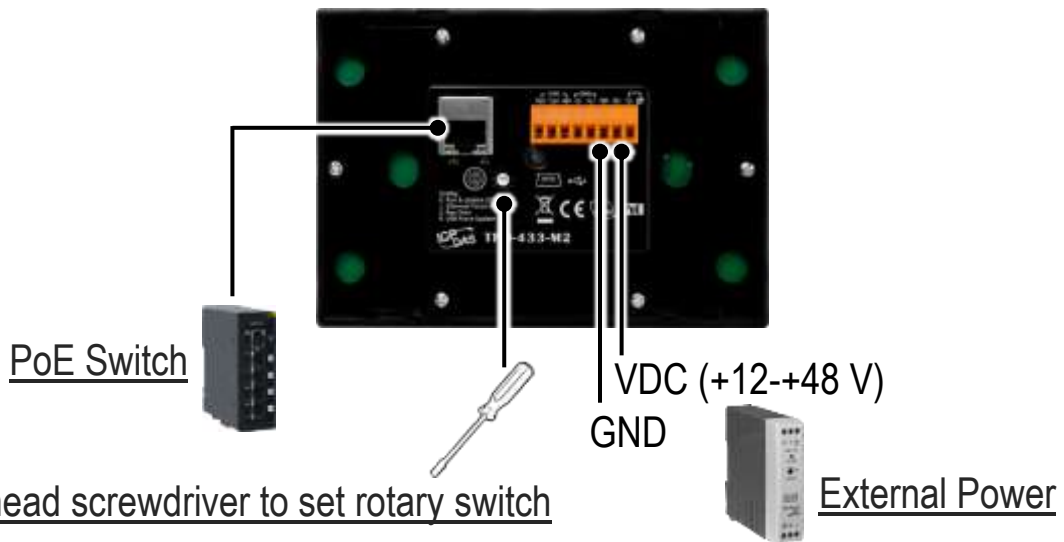

2. Supply power to the TPD-433-M2, wait for several seconds and then you can see the default program run on it.

3. Try to touch on the icons on the bottom-right corner of the screen of the TPD-433-M2 and you can find that TPD-433-M2 switches to the setting pages.

5 Hardware Installation

External Wall Box, EWB-T43F (optional)	Outlet Box, OB120 (optional)	Outlet Box, OB140F (optional)	Outlet Box, OB140FP (optional)

檢查配件

感謝您購買泓格的 TPD-433-M2 產品。產品包裝內應包含下列配件：



TPD-433-M2 x 1



產品須知 x 1 (本文件)



面板蓋 x 1



圓頭螺絲 x 2

參考資訊

如果您是第一次使用 TPD-433-M2，請參閱 **TouchPAD 硬體使用手冊** 的“**第 3 章 啟動 TouchPAD**”來了解如何安裝免費的開發軟體 HMIWorks 並建立第一個專案以及更多詳細的相關資訊。

- 相關文件，如使用手冊、應用程式介面指南(API Reference) 等：
<http://ftp.icpdas.com/pub/cd/touchpad/document/>
- 免費開發軟體，HMIWorks 版本 2.10.10 或以上版本：
<http://ftp.icpdas.com/pub/cd/touchpad/setup/>

如有任何問題歡迎使用 E-mail 聯繫我們，我們將會為您提供完善的諮詢服務。

1

外觀

前配置圖

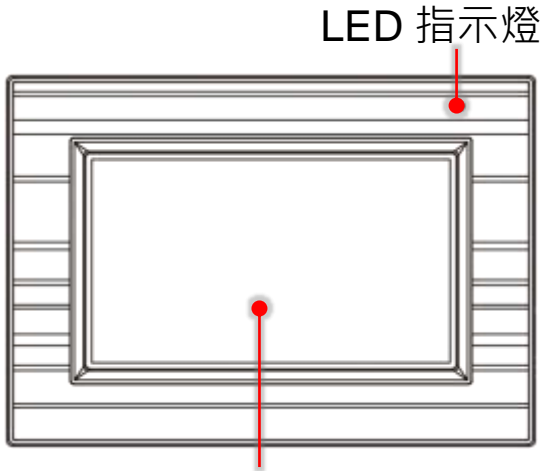

後配置圖

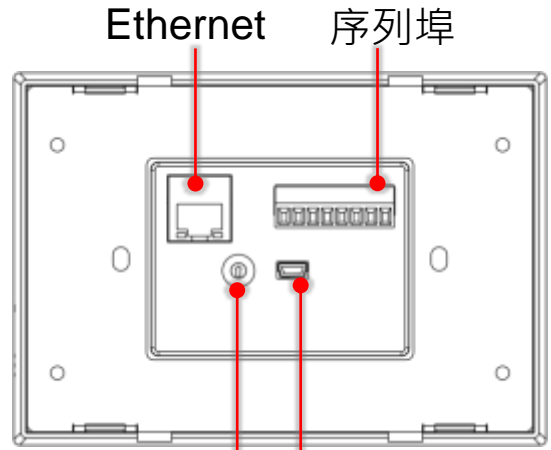

2

腳位定義

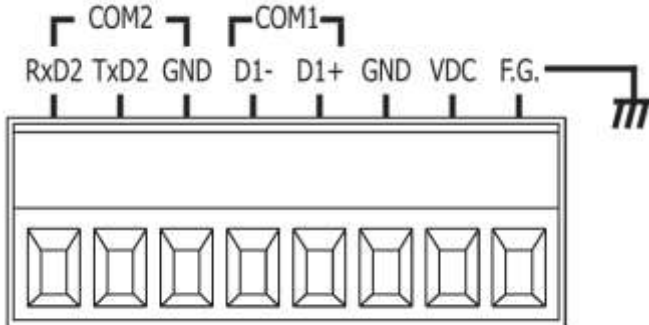

Pin	說明
F.G.	機架接地，F.G. (連接到內部的 EMI 或 ESD 保護電路)，請接到大地
VDC	直流電壓輸入 (範圍：+12 V ~ +48 V)
GND	連到電源的接地端
D1+	RS-485 網路的正訊號線
D1-	RS-485 網路的負訊號線
GND	接地端
TxD2	RS-232 的傳送資料腳位
RxD2	RS-232 的接收資料腳位

3

旋轉開關及出廠預設值

旋轉開關的配置模式定義:

	No	模式	說明
	0	Run & Update (Ethernet)	執行/更新程式，用於程式開發階段 (能執行程式，也能進行更新)。(出廠預設)
	1	Ethernet Force Update	強制更新，當 TouchPAD 上的程式嚴重毀損時可用此模式透過 Ethernet 更新。
	2	Run Only	執行程式。
	9	USB Force Update	透過 USB 更新程式。

網路設定出廠預設如下表:

IP Address	192.168.255.1
Subnet Mask	255.255.0.0
Gateway	192.168.0.1

4

第一次使用 TPD-433-M2

1. 如下圖所示，將電源和接地線連接完成。或是有 RJ-45 的乙太網路接孔，可以準備一條網路線，透過乙太網路供電 (PoE)。然後將旋轉開關 (Rotary Switch) 轉到 0 (此時尚未供電)。

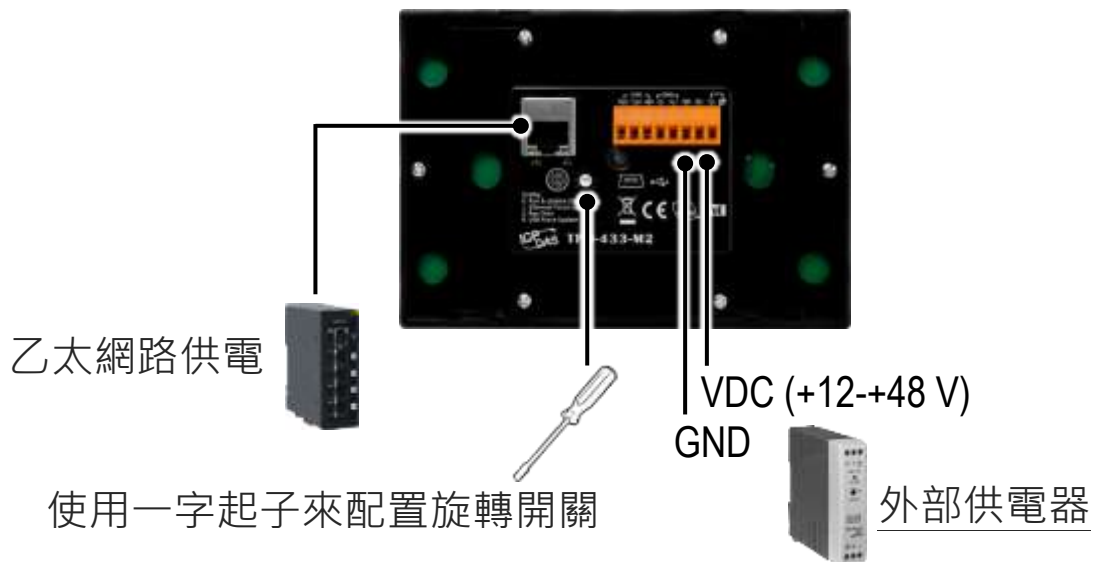

2. 開始供電給 TPD-433-M2，等待約數秒的開機時間，接著可以看到 TPD-433-M2 執行出貨預附的程式如左圖所示。

3. 試著按一下 TPD-433-M2 螢幕上面的圖示，TPD-433-M2 會切到其他的頁面。

5 硬體安裝

安裝於明盒 EWB-T43F (選購)	安裝於暗盒 OB120 (選購)	安裝於暗盒 OB140F (選購)	安裝於暗盒 OB140FP (選購)
