

# XP-8000-Atom-CE6 Series

## User Manual

(Windows CE-Based Family)



**XP-8041-Atom-CE6**



**XP-8141-Atom-CE6**



**XP-8341-Atom-CE6**



**XP-8741-Atom-CE6**

## ► Warranty

---

All products manufactured by ICP DAS are under warranty regarding defective materials for a period of one year, beginning from the date of delivery to the original purchaser.

## ► Warning

---

ICP DAS assumes no liability for any damage resulting from the use of this product. ICP DAS reserves the right to change this manual at any time without notice. The information furnished by ICP DAS is believed to be accurate and reliable. However, no responsibility is assumed by ICP DAS for its use, not for any infringements of patents or other rights of third parties resulting from its use.

## ► Copyright

---

Copyright © 2011 by ICP DAS Co., Ltd. All rights are reserved.

## ► Trademark

---

The names used for identification only may be registered trademarks of their respective companies.

## Contact US

---

If you have any problem, please feel free to contact us.

You can count on us for quick response.

Email: [service@icpdas.com](mailto:service@icpdas.com)

---

# Table of Contents

# Table Of Contents

Industrial Communication Products

<b>1. Introduction .....</b>	<b>7</b>
1.1. Features.....	9
1.2. Specifications.....	13
1.3. Overview.....	15
1.4. Dimension.....	24
1.5. Companion CD .....	29
1.6. Rescue CF Card .....	30
<b>2. Getting Started .....</b>	<b>31</b>
2.1. Mounting the Hardware.....	33
2.1.1. Mounting the XP-8000-Atom-CE6 .....	34
2.1.2. Deploying a Basic XP-8000-Atom-CE6 System .....	37
2.1.3. Inserting the I/O Modules.....	38
2.1.4. Powering up the XP-8000-Atom-CE6 .....	40
2.2. Installing the Tools and Utilities.....	44
2.3. Configure the Boot Mode .....	45
2.4. Changing the User Interface Language .....	47
2.5. Using XPAC Utility to Configure XP-8000-Atom-CE6 Basic Functionality .....	49
2.6. Using Remote Display to Control the XP-8000-Atom-CE6 Remotely .....	50
2.7. Using DCON Utility to Configure the I/O Module.....	52
<b>3. Tools and Tasks .....</b>	<b>56</b>
3.1. Tools and Tasks on XPAC.....	58
3.1.1. DCON_CE .....	58
3.1.2. ISQLW35.....	59
3.1.3. modbus_master_tool .....	60
3.1.4. NAPOPC_CE6 .....	61
3.1.5. INotepad.....	62

- 3.1.6. RegEdit..... 63
- 3.1.7. Remote\_Display ..... 64
- 3.1.8. Send ToCOM..... 65
- 3.1.9. TaskMgr..... 66
- 3.1.10. XPAC\_Utility ..... 67
  - 3.1.10.1. Menu Bar.....68
  - 3.1.10.2. Property Tabs.....70
- 3.2. Tools and Tasks on PC..... 82
  - 3.2.1. DCON\_Utility ..... 82
  - 3.2.2. Remote\_Display ..... 83

## 4. Your First XP-8000-Atom-CE6 Program... 84

- 4.1. Selecting a Development Tools ..... 86
- 4.2. Installing the XP-8000-Atom-CE6 SDKs ..... 87
- 4.3. Creating Your First XP-8000-Atom-CE6 Program.... 92
  - 4.3.1. Your First XP-8000-Atom-CE6 Program with the VB.net 93
    - 4.3.1.1. Creating a New Project .....94
    - 4.3.1.2. Specifying the Path of the XPAC Reference 97
    - 4.3.1.3. Adding the Control to the Form .100
    - 4.3.1.4. Adding the Event Handling to the Control 102
    - 4.3.1.5. Uploading the Application to XP-8000-Atom-CE6 104
    - 4.3.1.6. Executing the Application on XP-8000-Atom-CE6 106
  - 4.3.2. Your First XP-8000-Atom-CE6 Program with the Visual C# 107
    - 4.3.2.1. Creating a New Project ..... 108
    - 4.3.2.2. Specifying the Path of the XPAC Reference 111
    - 4.3.2.3. Adding the Control to the Form .114
    - 4.3.2.4. Adding the Event Handling to the Control 116
    - 4.3.2.5. Uploading the Application to XP-8000-Atom-CE6 118
    - 4.3.2.6. Executing the Application on XP-8000-Atom-CE6 120
  - 4.3.3. Your First XP-8000-Atom-CE6 Program with the Visual C++ 121



- 4.3.3.1. Creating a New Project ..... 122
- 4.3.3.2. Configuring the Platform..... 127
- 4.3.3.3. Specifying the Path of the XPAC Reference 128
- 4.3.3.4. Adding the Control to the Form . 130
- 4.3.3.5. Adding the Event Handling to the Control 133
- 4.3.3.6. Uploading the Application to XP-8000-Atom-CE6 135
- 4.3.3.7. Executing the Application on XP-8000-Atom-CE6 137

## **5. Rescue and Backup ..... 138**

- 5.1. Restoring the XP-8000-Atom-CE6 ..... 140
- 5.2. Restoring the Rescue CF Card ..... 144

## **6. XP-8000-Atom-CE6 Updates ..... 148**

- 6.1. OS updates ..... 150
  - 6.1.1. OS Updates from Files ..... 151
  - 6.1.2. OS Updates using the Rescue CF Card ..... 152
- 6.2. SDK updates..... 153

## **Appendix A. Application of RS-485 Network 154**

- A.1. Basic RS-485 Network ..... 156
- A.2. Daisy Chain RS-485 Network ..... 157
- A.3. Star Type RS-485 Network..... 158
- A.4. Random RS-485 Network..... 160
- A.5. Master/Slave Settings..... 161
  - A.1.1. XPAC as a Master (Default) ..... 162
  - A.1.1. XPAC as a Slave..... 164

## **Appendix B. Tips & FAQ..... 166**

- B1. How to use the Printer ..... 169
  - B.1.1. How to use the network printer..... 170

# Table Of Contents

Industrial Communication Products

B.1.2. How to use the USB printer.....	172
B.2. How to Online Debug the XP-8000-Atom-CE6 ...	173
B.3. How to automatically synchronize the XPAC clock with an Internet Time Server .....	181
B.4. How to add a user account to remote login the XPAC from PC	183
B.4.1. How to add a user account.....	184
B.4.2. How to Use telnet to remote login the XPAC from PC	186
B.4.3. How to remove the user from the login list .	188
B.5. How to use XPacSDK to program the XP-8000-Atom-CE6	189
B.5.1. How to Read the XPAC Mode with XPacSDK	190
B.5.2. How to Read the Module ID with XPAC API ..	191
B.5.3. How to Use the Multi-IO Module with XPAC API	192
B.6. How to update software from XP-8000-CE6 to XP-8000-Atom-CE	194
<b>Appendix C. Revision History.....</b>	<b>195</b>

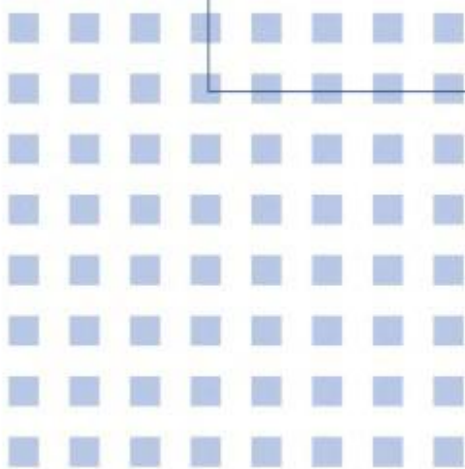
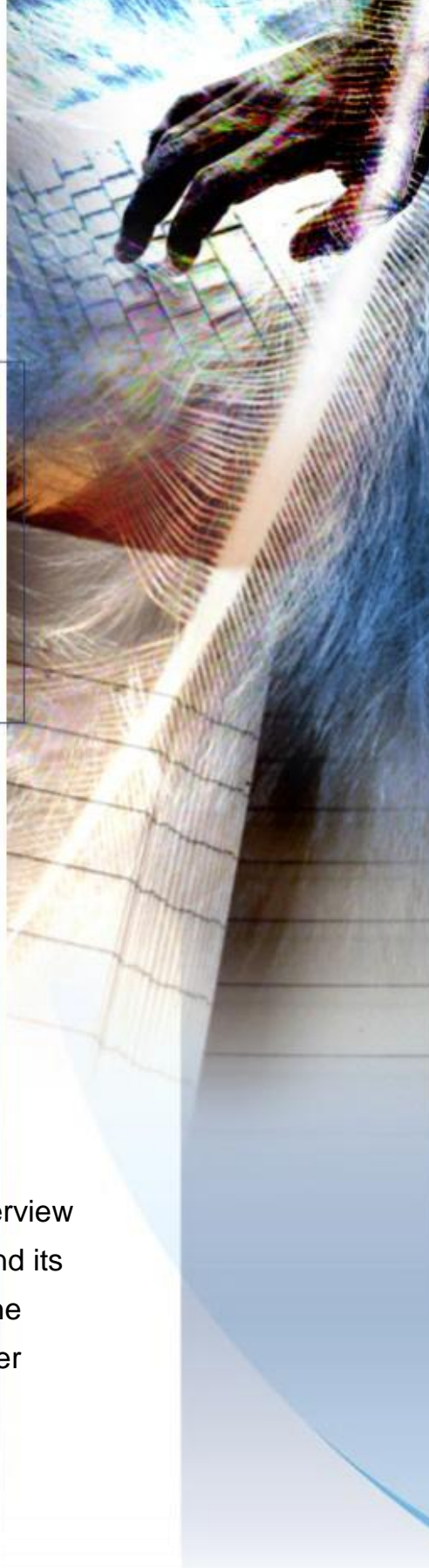

# 1. Introduction

This chapter provides an overview of the XP-8000-Atom-CE6 and its components that introduce the fundamental concepts for user familiar with the XP-8000-Atom-CE6.

XP-8000-Atom-CE6 family is the new generation Windows CE 6.0 based PACs of ICP DAS. It is equipped with an Intel Atom Z500 Series CPU, various connectivity (VGA, USB, Ethernet, RS-232/485) and 0/1/3/7 I/O slots for high performance parallel I/O modules (high profile I-8K Series) and serial I/O modules (high profile I-87K series).

The benefits of running Windows CE 6.0 on XP-8000-Atom-CE6 include hard real-time capability, small core size, fast boot speed, interrupt handling at a deeper level and achievable deterministic control.

XP-8000-Atom-CE6 is also capable of running PC-based control software such as Visual Basic .NET, Visual C# ..., etc. It has all of the best features of both traditional PLCs and Windows capable PCs.



For software copy protection, programmers can design software based on the 64-bit hardware serial number for making software copy protected.

# 1.1. Features

The XP-8000-Atom-CE6 family offers the most comprehensive configuration and remote system upgrade solutions to meet specific application requirements. The following list shows the hardware and software features designed to simplify installation, configuration and application.

## Hardware Features

### Power CPU Module

The most important features of the CPU module are

1. Intel Atom Z510 CPU (1.1 GHz)
2. DDR (512 MB), Built-in Flash Disk (2 GB)
3. EEPROM (16 KB), CF Card (2 GB)

### Built-in 1 VGA Port and 4 USB 2.0 Port

The built-in VGA port and USB port enables connection to a regular LCD display and USB equipment (keyboard, mouse, memory stick), it can allow you to operate the HMI or SCADA software (running on the XP-8000-Atom-CE6) with display, keyboard and mouse just as how they usually did on regular PCs.

### Audio with Microphone and Earphone jacks

The microphone and earphone jack enables connection to external audio device for playing and recording sounds.



### 64-bit Hardware Serial Number

The 64-bit hardware serial number is unique and individual. Every serial number of XP-8000-Atom-CE6 is different. It can allow you to add a checking mechanism to their AP to prevent software from pirating.

## **Built-in Flash Disk (2 GB)**

In normal situation, you can store the AP or data to the CF card or USB flash disk. But in some vibration environment (for example, like driving ships), the two storage media would be in bad connection. Then the built-in Flash disk will be the best storage media in such the vibration environment.

## **Rich I/O Expansion Ability (RS-232/485, Ethernet, FRnet, CAN)**

Beside the local I/O slots, XP-8000-Atom-CE6 also equips several RS-232/485 ports, two Ethernet ports to connect serial I/O and Ethernet I/O. And with FRnet and CAN communication module in local slot, FRnet I/O and CAN devices are easy to be integrated.

## **Dual Watchdog Timer**

A system could be hanged up when the OS or the AP fails. There are two watchdogs (OS watchdog and Hardware watchdog) designed to automatically reset the CPU when the situations happen. The design will increase the reliability of the system.

## **Dual Battery-Backup SRAM (512 KB)**

To maintain important data while power off, non-volatile memory is the ideal design. The XP-8000-Atom-CE6 equips a 512 KB SRAM with two Li-batteries to maintain data while power off.

The two Li-batteries can continually supply power to the 512 KB SRAM to retain the data for 5 years; and the dual-battery design can avoid data loss while replacing a new battery.

## **Dual Ethernet Ports**

XP-8000-Atom-CE6 provides two Ethernet ports. The two Ethernet ports can be used to implement redundant Ethernet communication and separate Ethernet communication (one for global Internet, one for private Ethernet).

## **Redundant Power Input**

To prevent the XP-8000-Atom-CE6 from failing by the power loss, the power module is designed with two input connectors. Once a power input fails, the power module switches to the other power input immediately. And there is a relay output for informing the power failure.



## Ventilated Housing Design Allows Operation Between -25 ~ +75 °C

Each XP-8000-Atom-CE6 is housed in a plastic-based box with a column-like ventilator that can help to cool the working environment inside the box and allow the XP-8000-Atom-CE6 operating between -25 °C and +75 °C

## Software Features

### Windows Compact Edition CE 6.0

Most of the popular features in MS software are included, such as

1. FTP Server
2. HTTP Server
3. ASP (Java script, VB script)
4. SQL Server Compact Edition 3.5
5. .NET Compact Framework 3.5



### System Rescue Mechanism

The XP-8000-Atom-CE6 supports Ghost solution suite. Ghost is a popular data backup and recovery utility that can be used to restore your XP-8000-Atom-CE6 hard drive in the event of a hard-drive crash, or any other catastrophe that leaves your computer out of commission.

For more information about backing up and restoring data via Ghost, please refer to "Chapter 5. Restore and Recover".

### Remote Display (VCEP)

ICPDAS VCEP is designed for managing your XP-8000-Atom-CE6 anywhere. No matter where you are, ICPDAS VCEP provides a convenient environment on the Desktop PC and lets you control your XP-8000-Atom-CE6 remotely.



## Built-In OPC Server

**NAPOPC\_CE6** is an OPC server and SCADA software can easily integrate I/O modules through it. Furthermore, it also provides a library which users can use to develop their AP by VC++, C# or VB.Net.

**NAPOPC\_CE6 not only supports I/O modules in local slots, but also supports remote I/O modules with the following protocols via the RS-232/485 or Ethernet:**

1. Modbus/RTU
2. Modbus/ASCII
3. Modbus/TCP
4. DCON

## Rich Software Solutions

On the XP-8000-Atom-CE6, ICP DAS provides the following software solutions to fit in different applications.

### 1. Visual Studio .NET 2005/2008 solution:

SDK as well as demo programs for Visual C# .NET, Visual Basic .NET and Visual C++ are provided.

### 2. SoftPLC solution:

A. ISaGRAF supports IEC61131-3 languages, Ladder Diagram (LD), Structured Text (ST), Function Block Diagram (FBD), Sequential Function Chart (SFC), Instruction List (IL), and Flow Chart (FC).

B. KW-software supports IEC61131-3 languages and HMI features.

### 3. SCADA solution:

Indusoft provides simple “drag and drop”, “point and click” developing environment for HMI and SCADA applications.

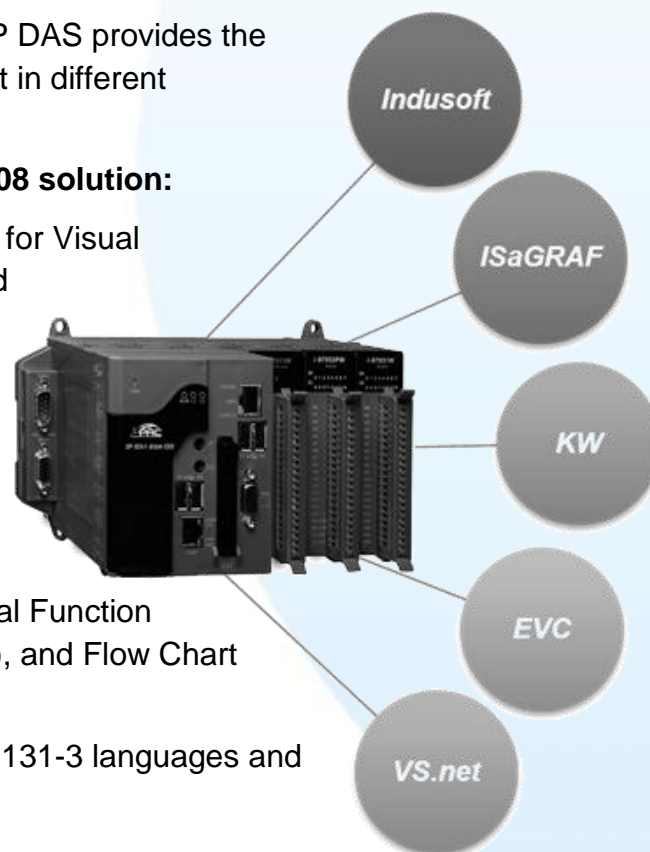



## 1.2. Specifications

The table below summarizes the specifications of the XP-8000-Atom-CE6, and lists the accessories that XP-8000-Atom-CE6 supports.

		Specification		
Model	XP-8041-Atom-CE6	XP-8141-Atom-CE6	XP-8341-Atom-CE6	XP-8741-Atom-CE6
<b>Software System</b>				
Operating System	Windows CE 6.0 core version			
.Net Compact Framework	3.5			
Embedded Service	FTP server, ASP Web server (supports VB script, JAVA script), SQL compact edition 3.5			
SDK Provided	DII for Visual Studio.Net 2003/2005/2008			
Multilanguage Support	English, German, French, Spanish, Russian, Italian, Japanese, Simplified Chinese, Traditional Chinese, Korean, Portuguese			
<b>CPU Module</b>				
CPU	Intel Atom Z510 CPU (1.1 GHz)			
System Memory	512 MB DDR2			
Dual Battery Backup SRAM	512 KB (for 5 years data retain while power off)			
Flash	2 GB as IDE Master			
EEPROM	16 KB, Data Retention: 40 years, 1,000,000 erase/write cycles			
CF Card	2 GB (support up 32 GB)			
RTC (Real Time Clock)	Provide seconds, minutes, hours, day of week/month, month and year			
LED Indicator	4			
64-bit Hardware Serial Number	Yes, for software copy protection			
Dual Watchdog Timers	Yes			
Rotary Switch	Yes (0 ~ 9)			
DIP Switch	-	Yes (8 bits)		
Audio	Microphone-In and Earphone-Out			
<b>VGA &amp; Communication Ports</b>				
VGA	Yes (resolution: 1400 x 1050, 1280 x 1024, 1024 x 768, 800 x 600, 640 x 480)			
Ethernet (Giga bit)	RJ-45 x 2, 10/100/1000 Base-T (Auto-negotiating, Auto MDI/MDI-X, LED indicators)			
USB 2.0	4			
COM 1	RS-485 (D2+, D2-); non-isolated Internal communication with the high profile I-87K series modules in slots			
COM 2	RS-232 (RXD, TXD and GND); non-isolated			
COM 3	RS-485	D2+, D2-; self-tuner ASIC inside		
	Isolation	3000 V <sub>DC</sub>		
COM 4	RS-232/RS-485 (Rx/D, Tx/D, CTS, RTS and GND for RS-232, Data+ and Data – for RS-485); non-isolated			

COM 5	RS-232 (Rx, Tx, CTS, RTS, DSR, DTR, CD, RI and GND); non-isolated			
<b>I/O Expansion Slots (for high profile I-8K and I-87K modules only)</b>				
Slot Number	0 slot	1 slot	4 slots	8 slots
Hot Swap * will be available	For high profile I-87K modules only			
<b>Mechanical</b>				
Dimensions (W x L x H)	95 x 132 x 111 mm	N/A	231 x 132 x 111 mm	355 x 132 x 111 mm
Installation	DIN-Rail or wall mounting			
<b>Environmental</b>				
Operating Temperature	-25 ~ +75 °C			
Storage Temperature	-30 ~ +85 °C			
Ambient Relative Humidity	5 ~ 90 % RH, non-condensing			
<b>Power</b>				
Input Range	+10 ~ +30 V <sub>DC</sub>			
Isolation	1 kV			
Redundant Power Inputs	Yes, with one power relay (1A @ 24 V <sub>DC</sub> ) for alarm			
Capacity	8 W	N/A	30 W	30 W
Consumption	7.3 W (0.3 A @ 24 V <sub>DC</sub> )	N/A	9.1 W (0.38 A @ 24 V <sub>DC</sub> )	9.6 W (0.4 A @ 24 V <sub>DC</sub> )

## Accessories

Model	
DRS-125	125 mm length , Stainless 35 mm DIN-Rail
DRS-240	240 mm length , Stainless 35 mm DIN-Rail
DRS-360	360 mm length , Stainless 35 mm DIN-Rail
DP-660	24 V <sub>DC</sub> /2.5 A, 60 W and 5 VDC/0.5 A, 2.5 W Power Supply with DIN-Rail Mounting
DP-1200	24 V <sub>DC</sub> /5.0 A, 120 W Power Supply with DIN-Rail Mounting
MDR-20-24	24 V <sub>DC</sub> /1.0 A, 24 W Power Supply with DIN-Rail Mounting
MDR-60-24	24 V <sub>DC</sub> /2.5 A, 60 W Power Supply with DIN-Rail Mounting

# 1.3. Overview

The XP-8000-Atom-CE6 contains several interfaces and peripherals that can be integrated with external systems. Here is an overview of the components and its descriptions. The details of these items are as follows:

## XP-8041-Atom-CE6

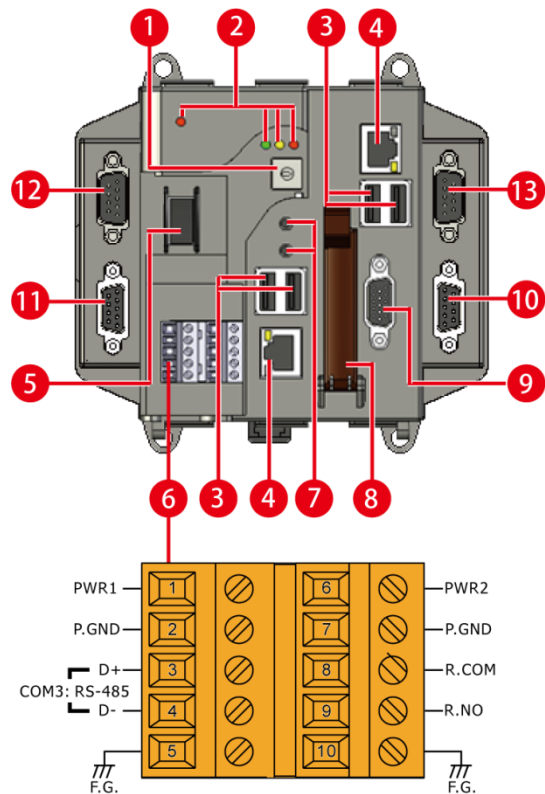

## XP-8141-Atom-CE6

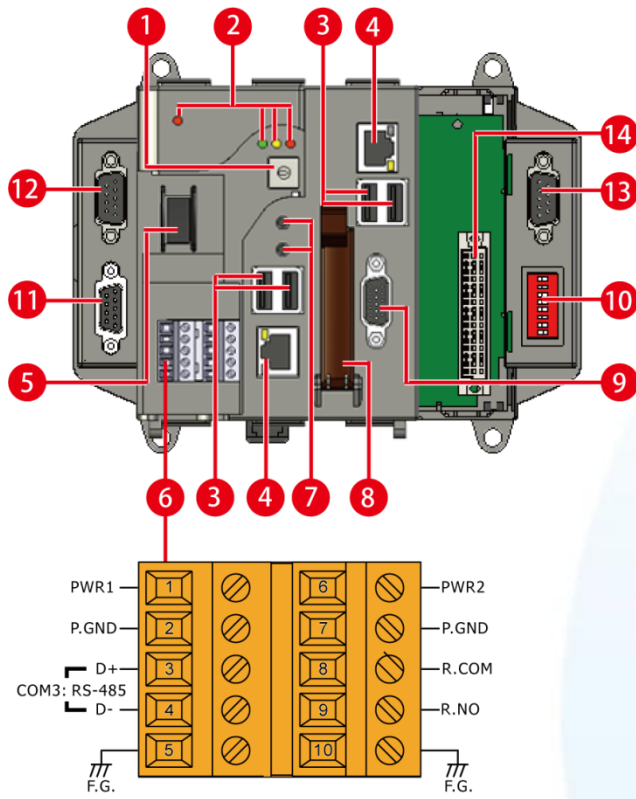

## XP-8341-Atom-CE6

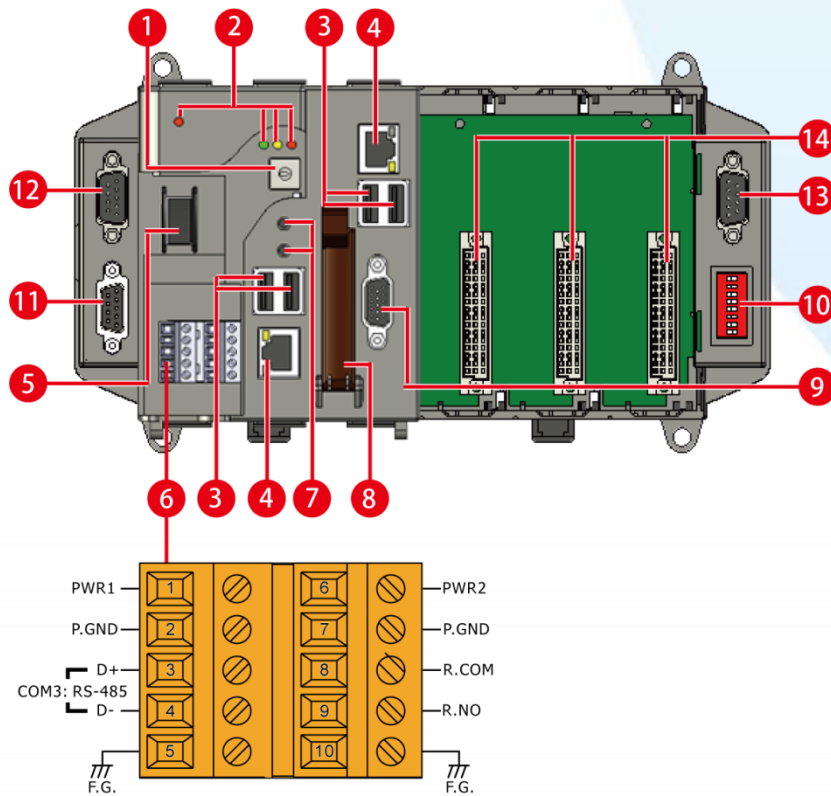

# XP-8741-Atom-CE6

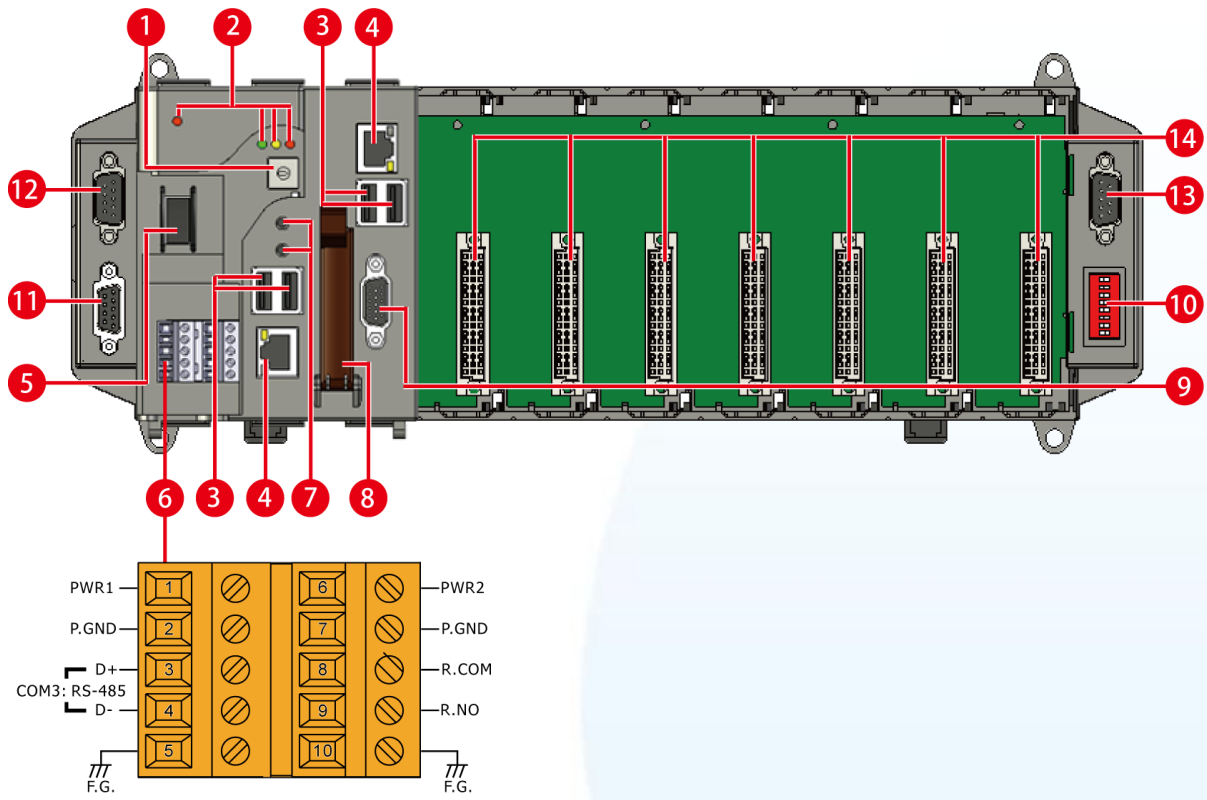

## 1. Rotary Switch

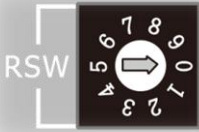

The Rotary Switch is an operating mode selector switch which provides four functions, the selection of operating mode and authorization control for the XP-8000-Atom-CE6.

For more information about the operating mode, please refer to “2.3. Configuring the Boot Mode”

## 2. LED Indicators

The XP-8000-Atom-CE6 contains four LED indicators. The first is labeled PWR, located near the power switch and shows the power status. The three others are located next the rotary switch, the left one is labeled RUN and shows the operation status, the two others are denoted L1 and L2 and used for user defined.

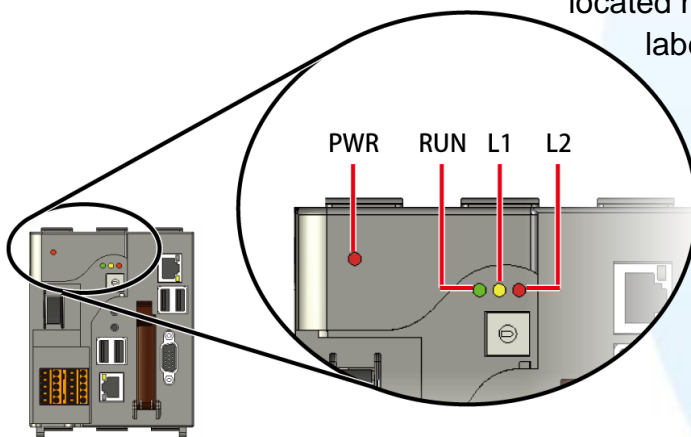

LED Indicator	Color (On state)	Meaning
PWR	Red	Power is on
RUN	Green	OS is running
L1	Yellow	User programmable LED
L2	Red	User programmable LED

### 3. USB Ports (P1 ~ P4)

The XP-8000-Atom-CE6 contains four USB ports that allow support for the USB devices such as mouse, keyboard or an external USB hard drive. These ports are denoted P1, P2, P3 and P4.

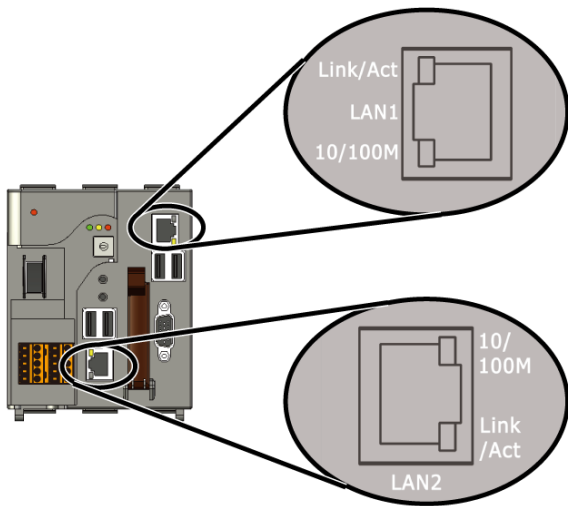
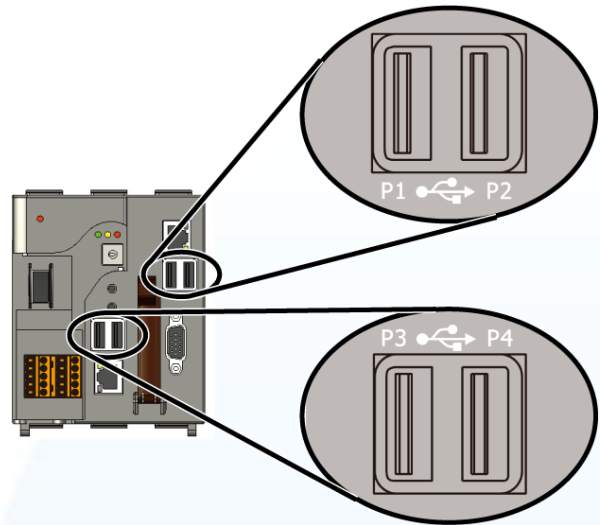

### 4. Ethernet Port (LAN1, LAN2)

The XP-8000-Atom-CE6 contains two Ethernet ports for using with network devices, and denoted as LAN1 and LAN2.



### 5. Power Switch

The power switch is a small switch that enables or disables power to electric circuits and loads in the XP-8000-Atom-CE6.

## 6. Connector

The connector has 10 pins arranged in 2 rows, as follows:

The pin assignments of the connector are as follows:

Pin	Signal	Description
1	PWR1	Power input 1
2	P.GND	
3	D+	COM3: RS-485
4	D-	
5	F.G.	Frame ground
6	PWR2	Power input 2
7	P.GND	
8	R.COM	Relay output
9	R.NO	
10	F.G.	Frame ground



## 7. Microphone and Earphone Jacks

The XP-8000-Atom-CE6 contains the microphone and earphone jack to the input and output of sound system.



## 8. CF Card Expansion Slot

The CF card expansion slot is an interface that can access and download information on a CF card to a XP-8000-Atom-CE6. The CF card can expand the memory up to 32 GB.





## 9. VGA Connector

A VGA connector is a 3-row 15-pin connector that can be used with a variety of supported VGA resolutions, ranging from 640 x 400 to 1400 x 1050 px.

## 10. COM1 (Only for XP-8041-Atom)

**Port Type:** Female

**Baud Rate:** 115200, 57600, 38400, 19200, 9600, 4800, 2400, 1200 bps

**Data Bit:** 5, 6, 7, 8

**Parity:** None, Even, Odd, Mark (Always 1), Space (Always 0)

**Stop Bit:** 1, 2, 1.5

**FIFO:** 16 bytes

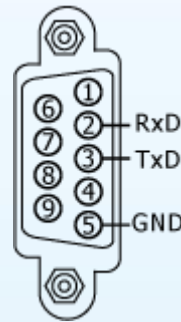

## 10. DIP Switch (For XP-8141-Atom, XP-8341-Atom and XP-8741-Atom)

The DIP switch can be used to set the Module ID to a number from 0 to 255. Do not use Module ID 0 for communication.

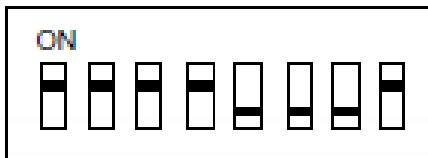

## 11. COM2 (RS-232)

**Port Type:** Female

**Baud Rate:** 115200, 57600, 38400, 19200,  
9600, 4800, 2400, 1200 bps

**Data Bit:** 5, 6, 7, 8

**Parity:** None, Even, Odd

**Stop Bit:** 1, 2, 1.5

**FIFO:** 1 byte

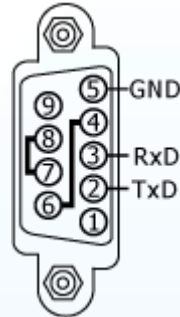

## 12. COM4 (RS-232/RS-485)

**Port Type:** Male

**Baud Rate:** 115200, 57600, 38400, 19200, 9600, 4800, 2400, 1200 bps

**Data Bit:** 5, 6, 7, 8

**Parity:** None, Even, Odd, Mark (Always 1), Space (Always 0)

**Stop Bit:** 1, 2, 1.5

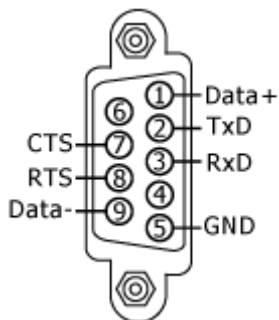

COM4 can be configured as either RS-232 or RS-485, that only can select one at a time and its configuration depends on the pin connections as follows:

**RS-232** (RXD, TXD, CTS, RTS and GND)

**RS-485** (Data+ and Data-)

There is no software configuration or hardware jumper needed.

## 13. COM5 (RS-232)

**Port Type:** Male

**Baud Rate:** 115200, 57600, 38400, 19200,  
9600, 4800, 2400, 1200 bps

**Data Bit:** 5, 6, 7, 8

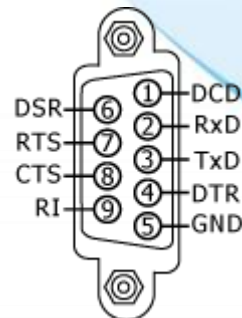

**Parity:** None, Even, Odd, Mark (Always 1), Space (Always 0)

**Stop Bit:** 1, 2, 1.5

**FIFO:** 16 bytes

The table below shows the data bit of each COM port and their corresponding stop bit.

data bit	stop bit
5, 6, 7, 8	1
5	1.5
6	2
7	2
8	2

## 14. I/O Slots

The XP-8000-Atom-CE6 contains some extra I/O slots except the XP-8041-Atom. The XP-8000-Atom-CE6 use I/O slots that can be expanded. They can serve in local and local expansion. The number of each type of the expansion I/O slot:

XP-8141: 1 I/O slot (Slot 0)

XP-8341: 3 I/O slots (Slot 0 ~ 2)

XP-8741: 7 I/O slots (Slot 0 ~ 6)

## 1.4. Dimension

The diagrams below provide the dimensions of the XP-8000-Atom-CE6 to use in defining your enclosure specifications. Remember to leave room for potential expansion if you are using other components in your system.

The height dimension is the same for all XP-8000-Atom-CE6. The width depending on your choose of I/O expansion slots. All dimensions are in millimeters.

# XP-8041-Atom-CE6

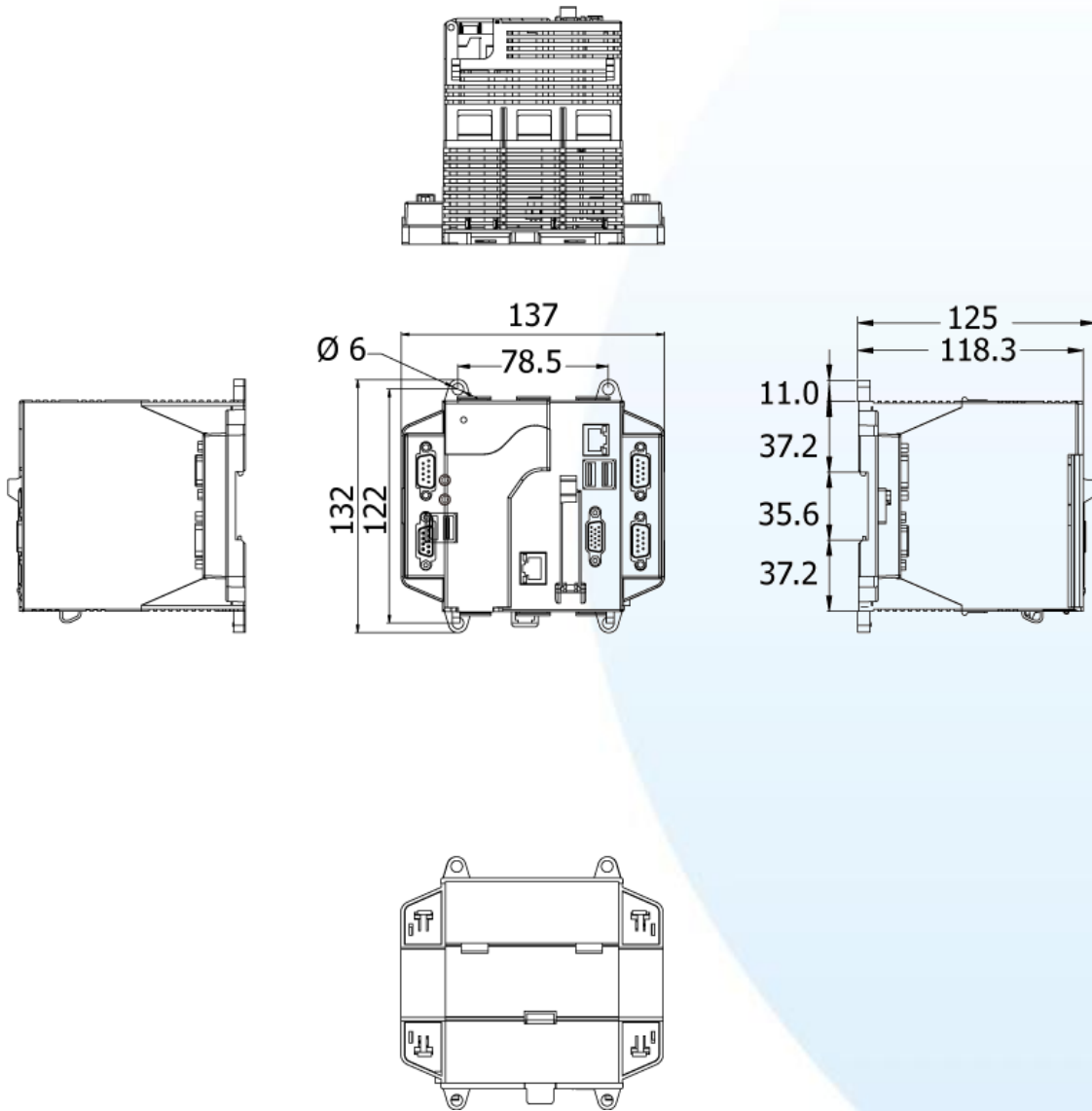

# XP-8141-Atom-CE6

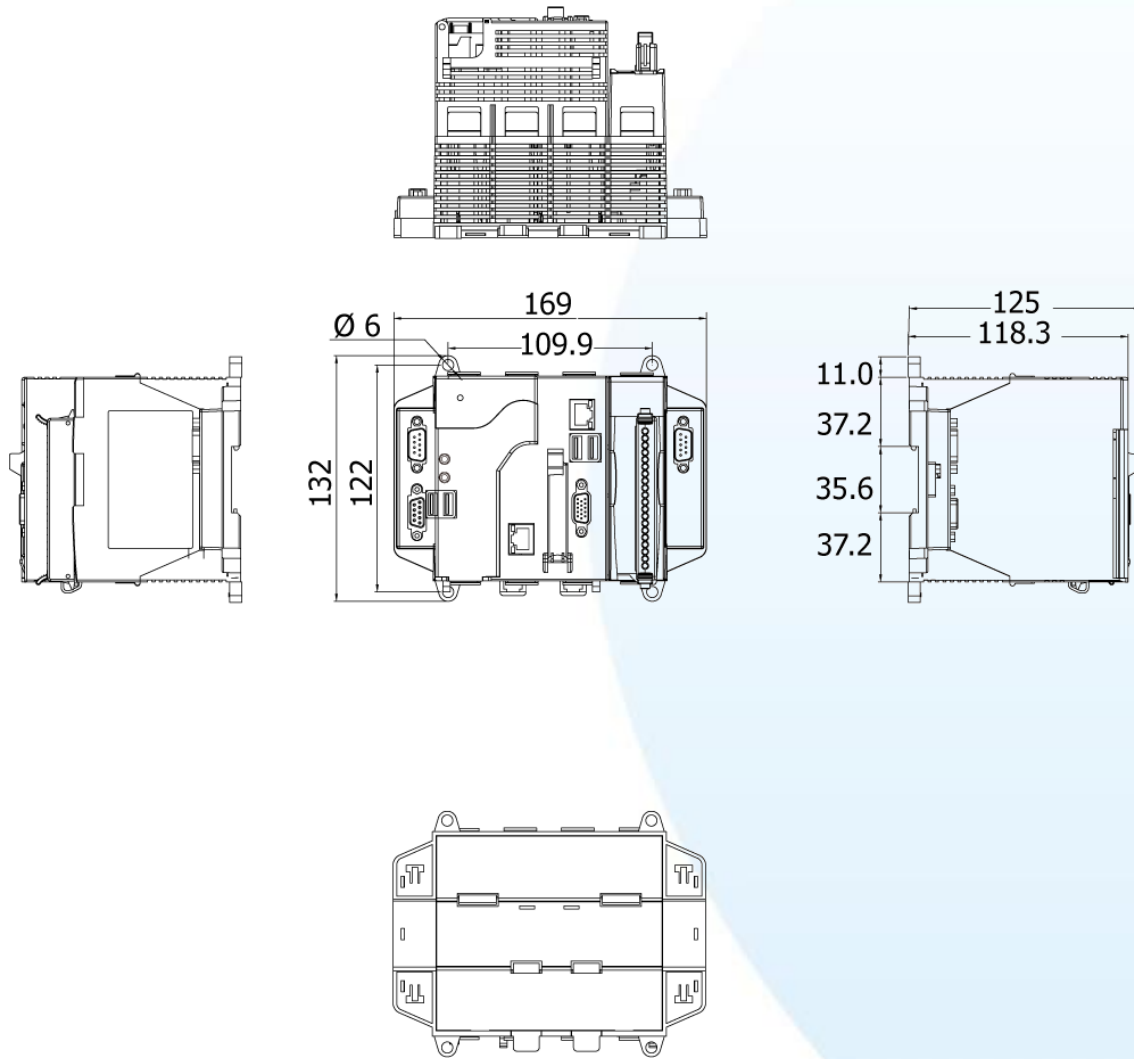

# XP-8341-Atom-CE6

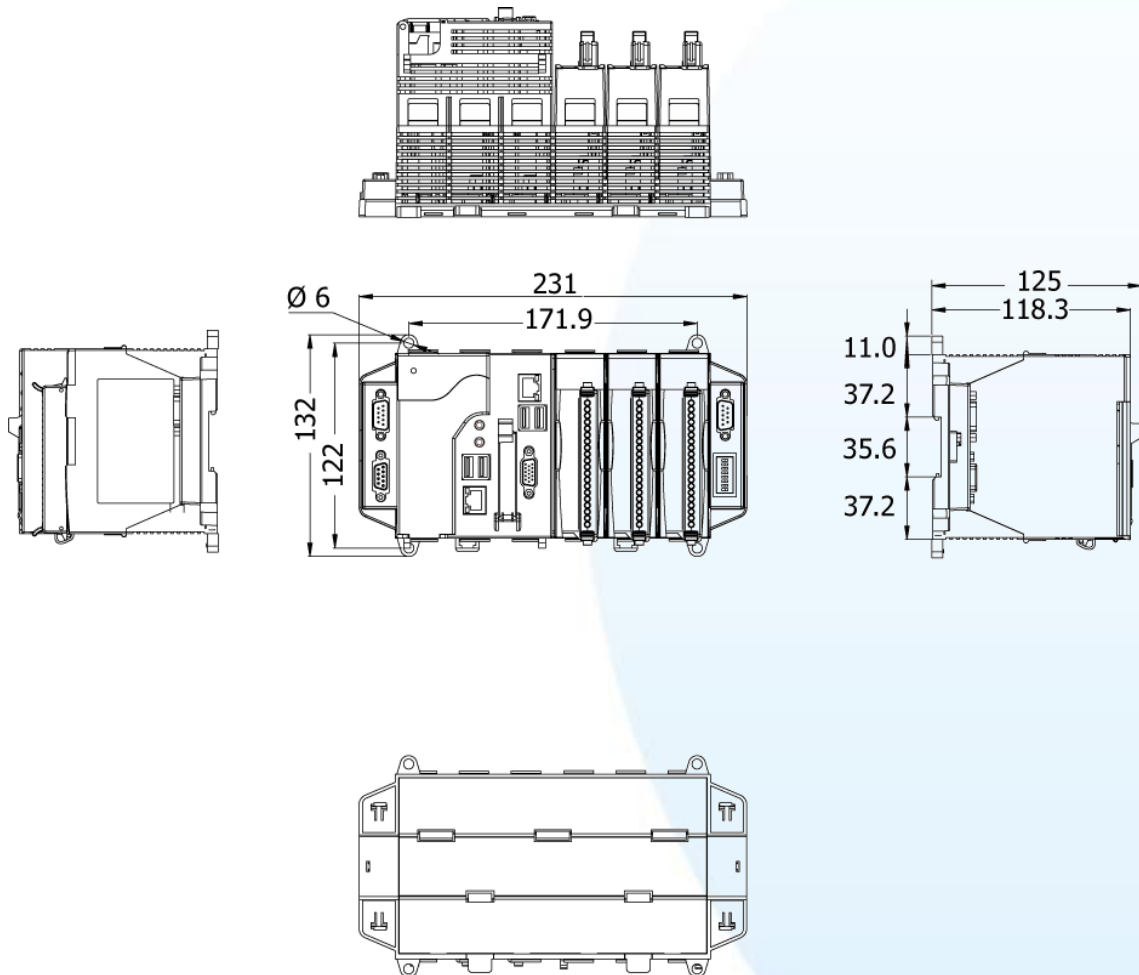

## XP-8741-Atom-CE6

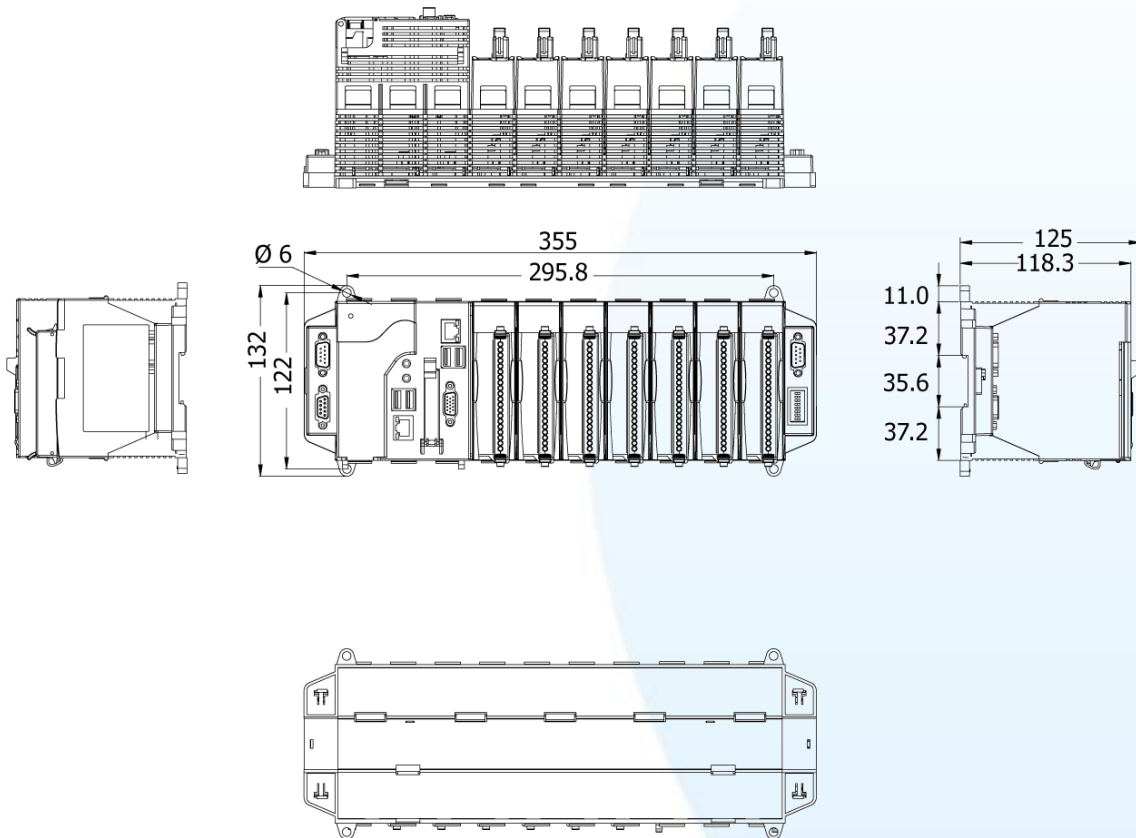



## 1.5. Companion CD

This package comes with a CD that provides a collection of the software utility, documentation, drivers, demo program and application. The CD contains several subdirectories located in \XPAC-Atom-CE6\ directory. All of them are listed below.

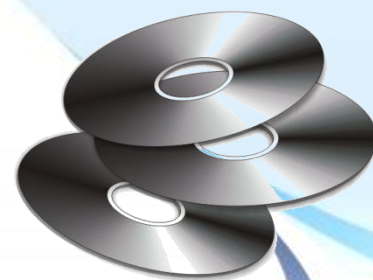
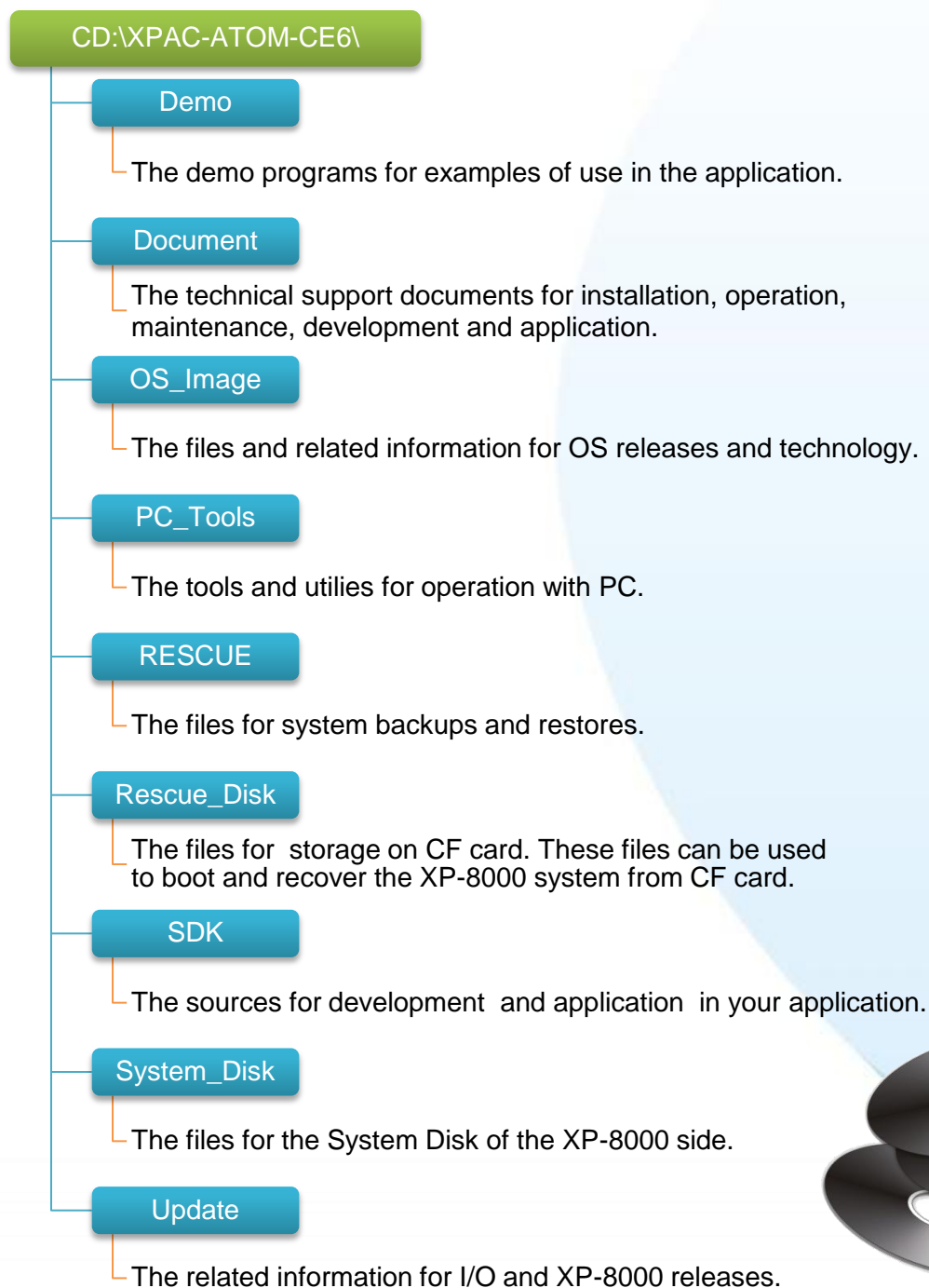

## 1.6. Rescue CF Card

The XP-8000-Atom-CE6 comes with a Rescue Compact Flash Card that not only supports rescue mechanism but also contains full usage documents, software tools and development resources related to the XP-8000-Atom-CE6. All of them are listed below.

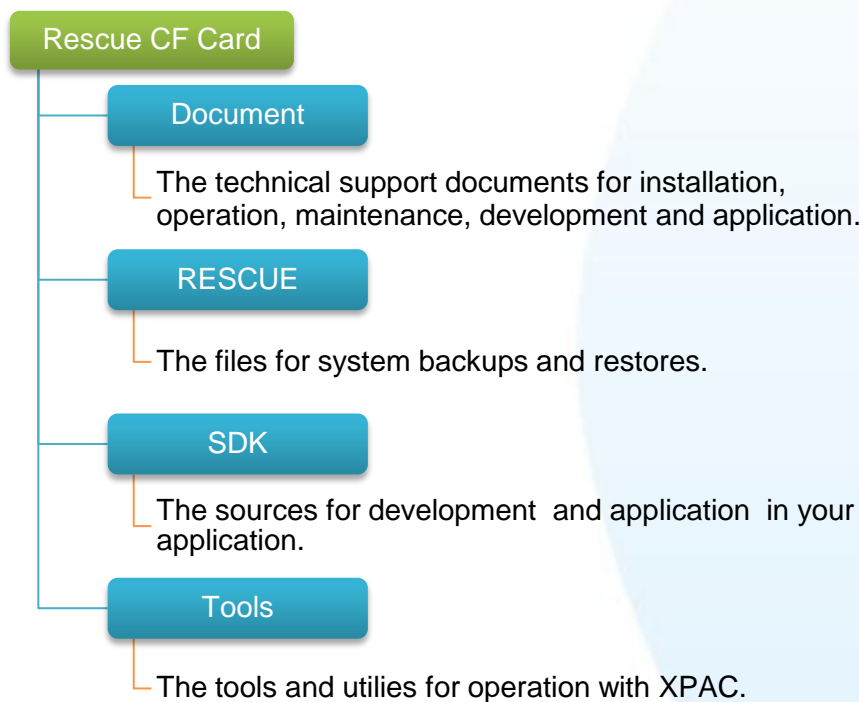

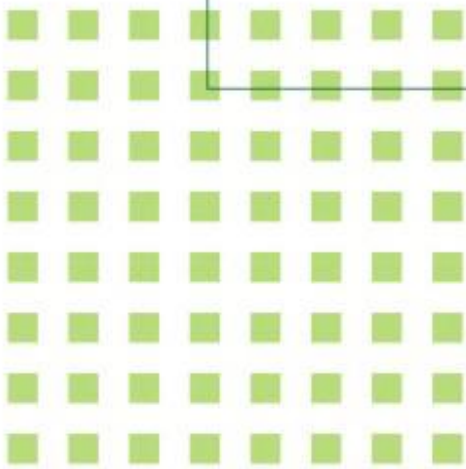
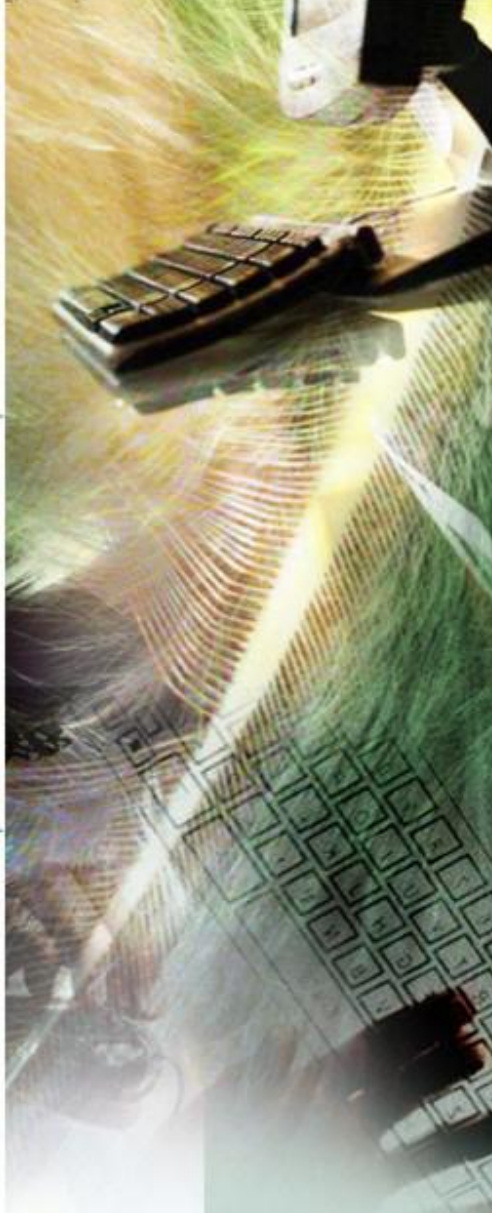

## 2. Getting Started

This chapter provides a guided tour that describes the steps needed to download, install, configure, and run the basic procedures for user working with the XP-8000-Atom-CE6 for the first time.

Before starting any task, please check the package contents. If any of the following package contents are missing or damaged, contact your dealer, or distributor.



**XP-8000-Atom-CE6 Series Module**

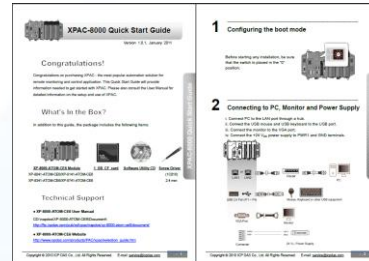

**Quick Start Guide**



**Software Utility CD**



**Screw Driver (1C016)**



## 2.1. Mounting the Hardware

Before you work with the XP-8000-Atom-CE6, you should have a basic understanding of hardware specification, such as the dimensions, the usable input-voltage range of the power supply, and the type of communication interfaces.

For more information about the hardware details, see section 1.2., “Specifications.”

For more information about the hardware dimensions, see section 1.4., “Dimension.”

## 2.1.1. Mounting the XP-8000-Atom-CE6

The XP-8000-Atom-CE6 can be mounted with the bottom of the chassis in the standard 35 mm DIN rail, or any other screw-mountable surface.

### Tips & Warnings

---



There must be a minimum clearance of 50mm between the XP-8000-Atom-CE6 and the top and bottom side of the enclosure panels must be provided.

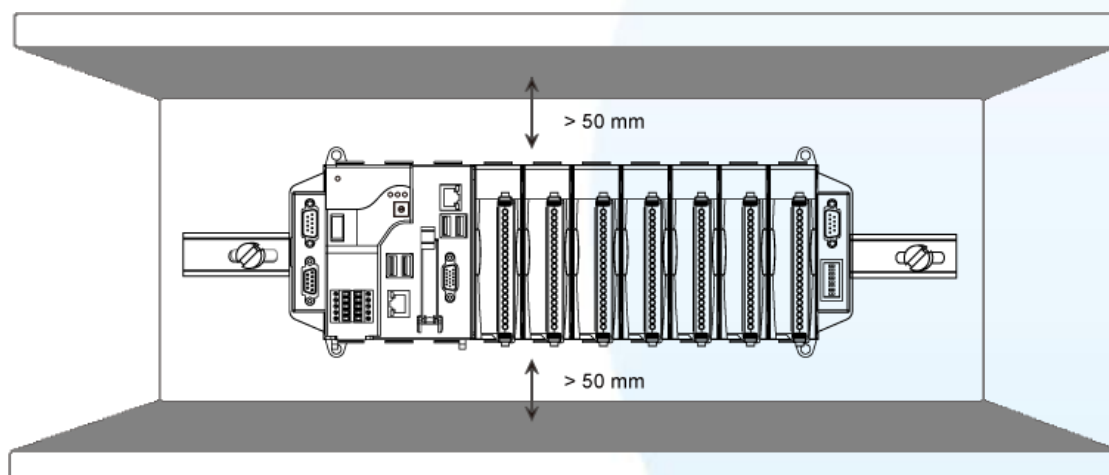

## Mount the Chassis on a DIN Rail

- i. Hook upper tab over upper flange of DIN rail.
- ii. Tilt the module toward DIN rail until it snaps securely to DIN rail.
- iii. Push up retaining clips

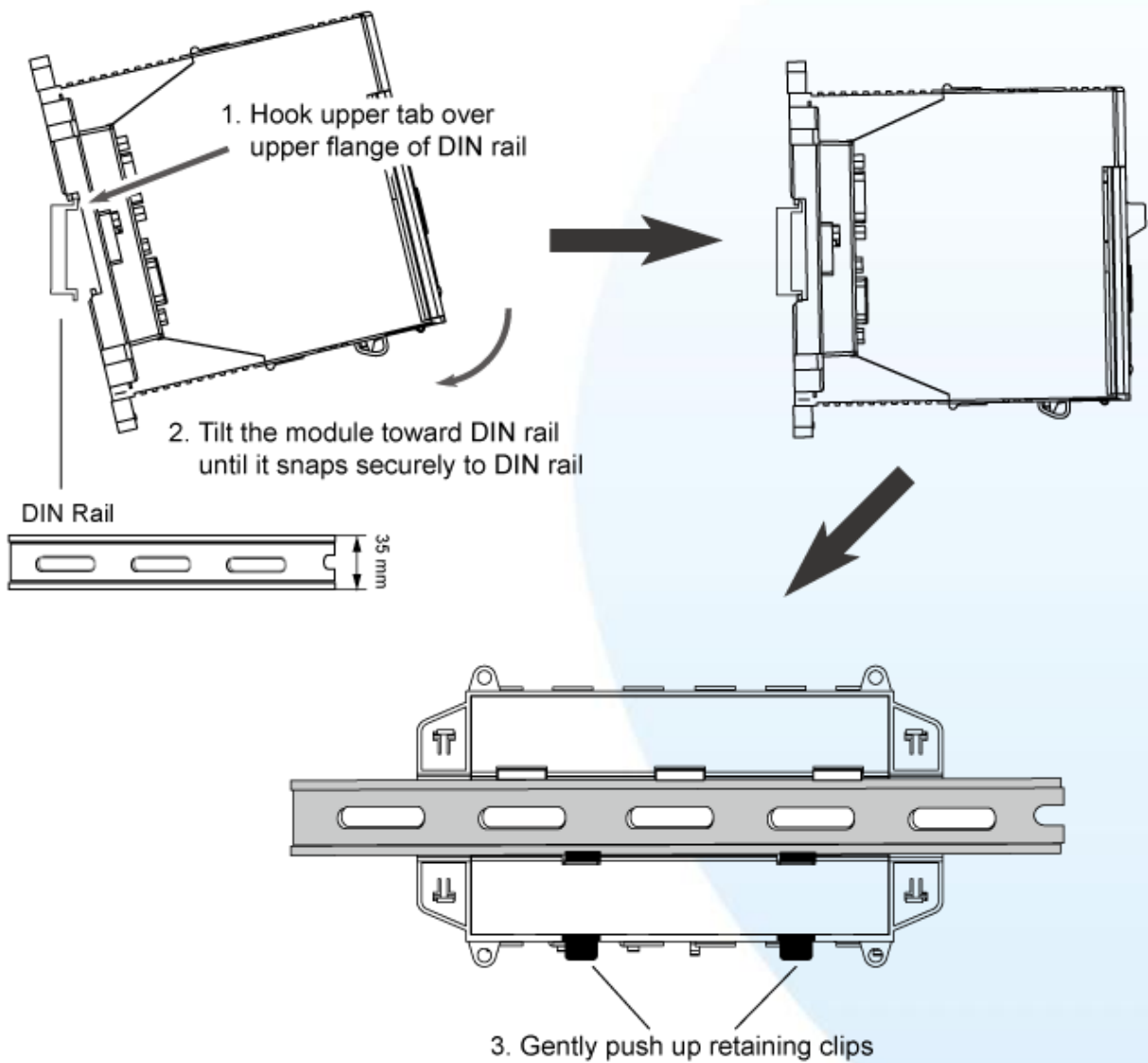



## Tips & Warnings

---



Connect the ground lead to the ground screw

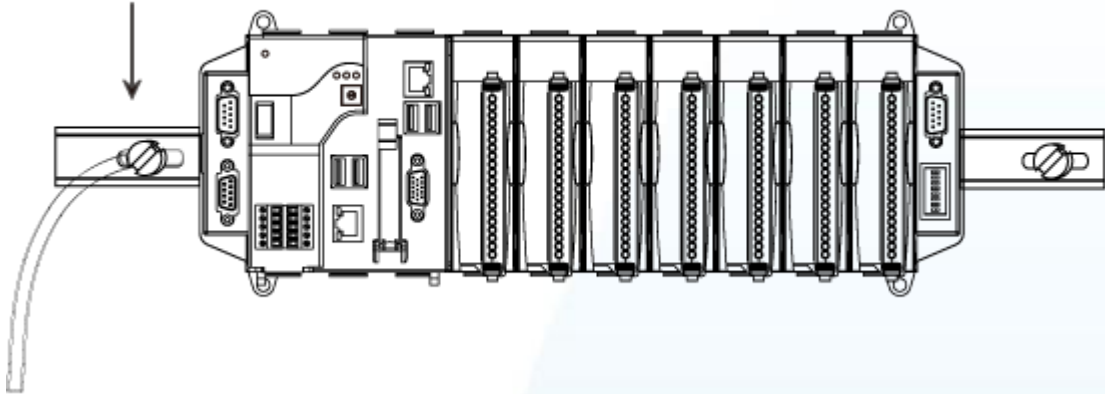

## Grounding

A good common ground reference (earth ground) is essential for proper operation of the XP-8000-Atom-CE6. One side of all control circuits, power circuits and the ground lead must be properly connected to earth ground by either installing a ground rod in close proximity to the enclosure or by connecting to the incoming power system ground. There must be a single-point ground (i.e. copper bus bar) for all devices in the enclosure that require an earth ground.

---

## Surface Mounting

- i. Install the four mounting screws into the 4 keyhole mounting holes.
- ii. Fasten the screws securely.

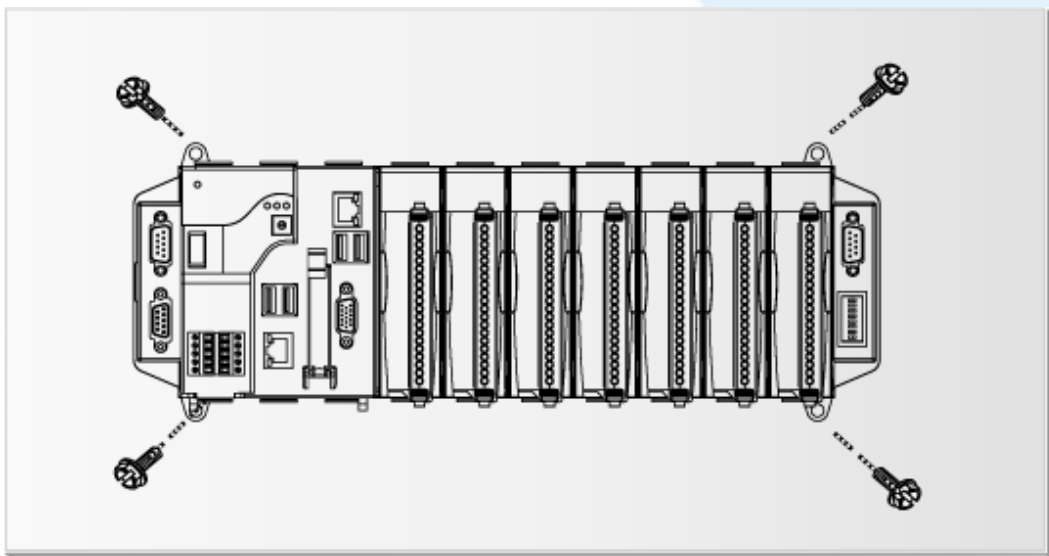



## 2.1.2. Deploying a Basic XP-8000-Atom-CE6 System

The XP-8000-Atom-CE6 provides a variety of communication interface to suit a range of applications. Here is a simple application for using the XP-8000-Atom-CE6 that is shown below.

- i. Use the LAN1 or LAN2 to connect to PC via the router.
- ii. Use USB 2.0 ports to connect to the USB mouse and keyboard.
- iii. Use the VGA port to connect to the monitor.

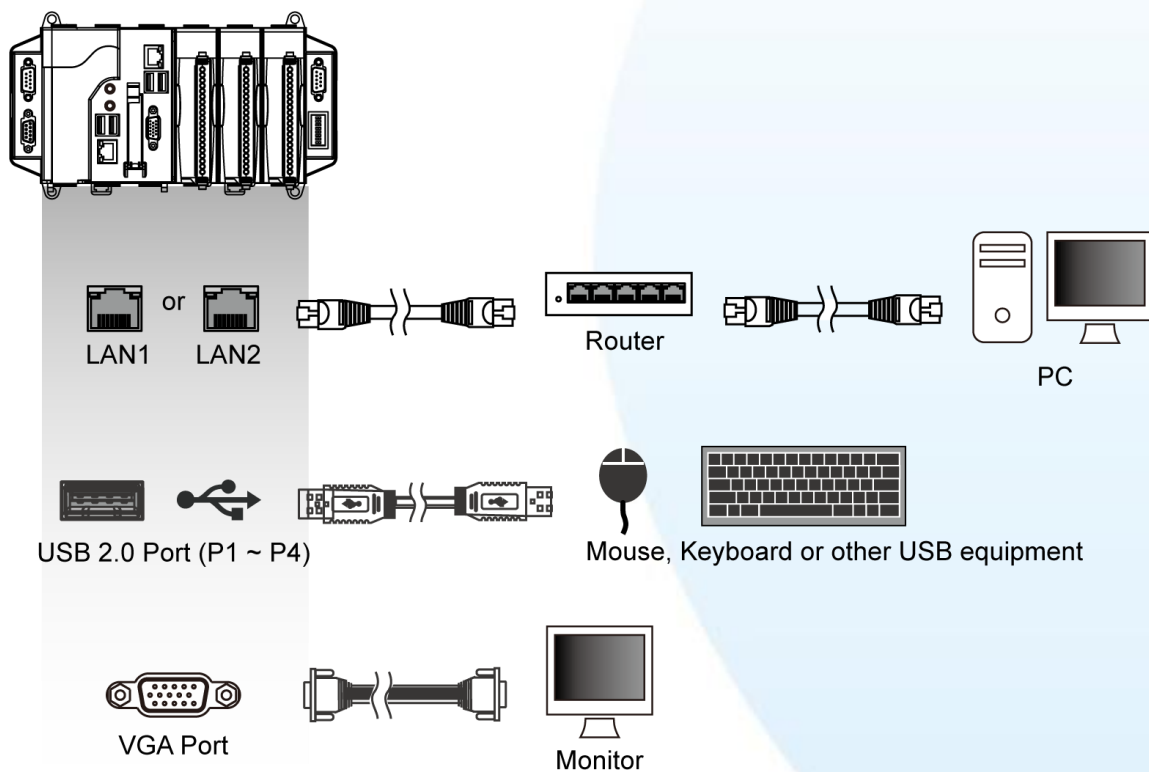

## 2.1.3. Inserting the I/O Modules

Except for XP-8041-Atom-CE6, the XP-8000-Atom-CE6 has 1/3/7 I/O expansion slots to expand the functions of the XP-8000-Atom-CE6, allowing it to communicate with external I/O modules. Before choosing the right I/O modules, you first need to know the I/O expansion capacities in order to choose the best expansion module for achieving maximal efficiency.

There are more than 30 high profile I/O modules available for interfacing many different measurements, including temperature, voltage, RTD, current, resistance, strain ... etc. For using them, please refer to the corresponding manual of those I/O modules.

For more information about the I/O expansion modules that are compatible with the XP-8000-Atom-CE6, please refer to

[http://www.icpdas.com/products/PAC/i-8000/8000\\_IO\\_modules.htm#i87](http://www.icpdas.com/products/PAC/i-8000/8000_IO_modules.htm#i87)

Here are step by step instructions on how to inserting the I/O modules.

**Step 1** Align circuit card with slot and press firmly to seat module into connector

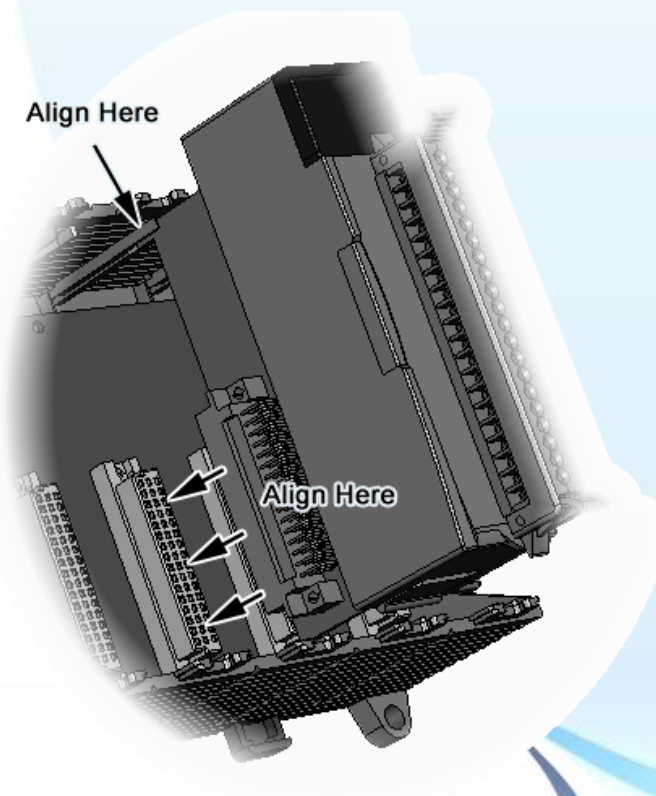

**Step 2** Pull top and bottom locking tabs toward module face. Click indicates lock is engaged

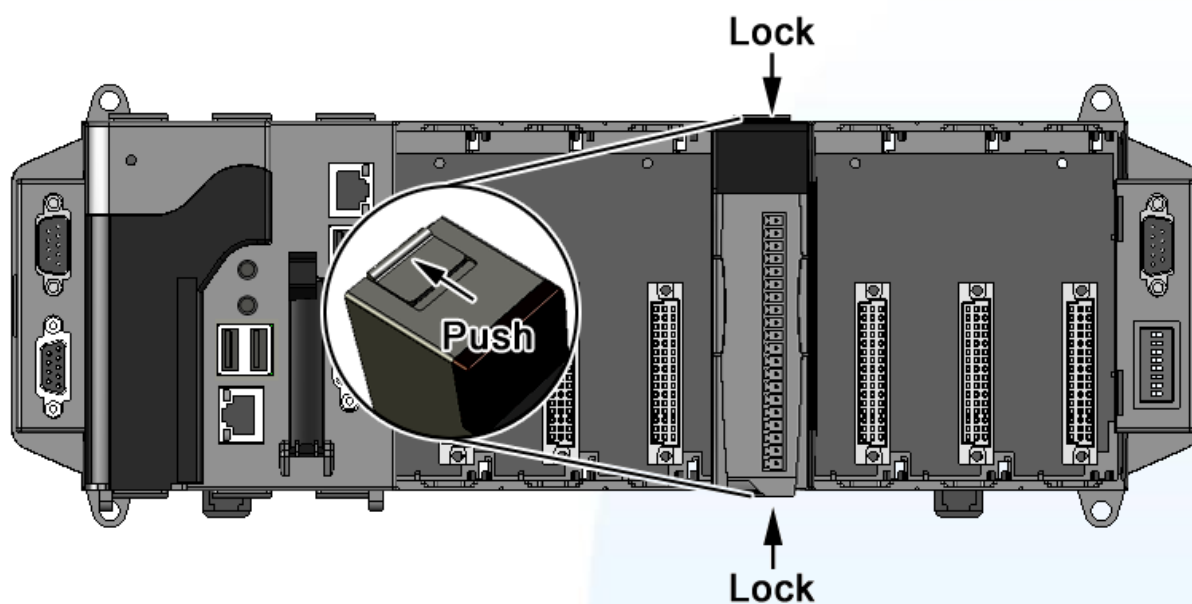

**Step 3** Attach field wiring using the terminal block, and then insert the terminal block

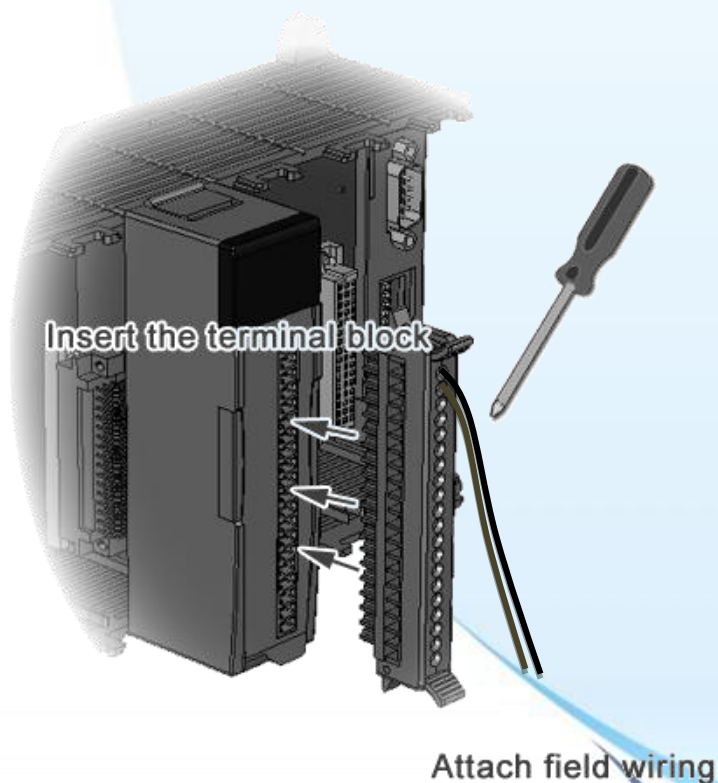

## 2.1.4. Powering up the XP-8000-Atom-CE6

The XP-8000-Atom-CE6 works with 24 VDC power, has redundant power inputs, provides two terminal blocks for PWR1 and PWR2 input.

### Step 1 Wire to power supply

There are two ways to supply power to the XP-8000-Atom-CE6.

#### Single power supply

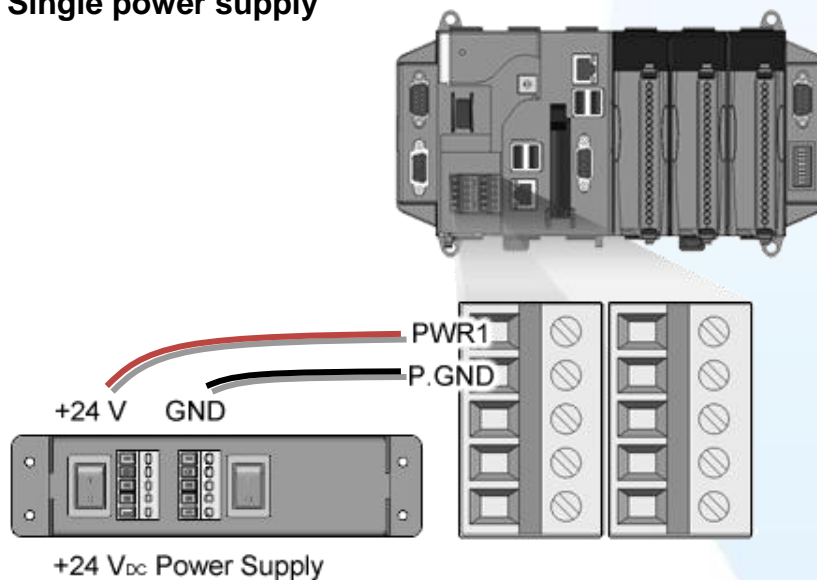

#### Tips & Warnings



Once you wire and power up the power supply, confirm the PWR indicator (Red LED) on the CPU module is on.

If the indicator is not on, check the voltage on the terminal block with a voltage meter. If you measure 24 VDC on the terminal block, the CPU module may be defective. Please contact us.

## Redundant power supply

The redundant power can be used single and used two self-governed power to supply to the system, PWR1 and PWR2 input at the same time. When one power fails, the other power acts as a backup, and automatically supplies power needs.

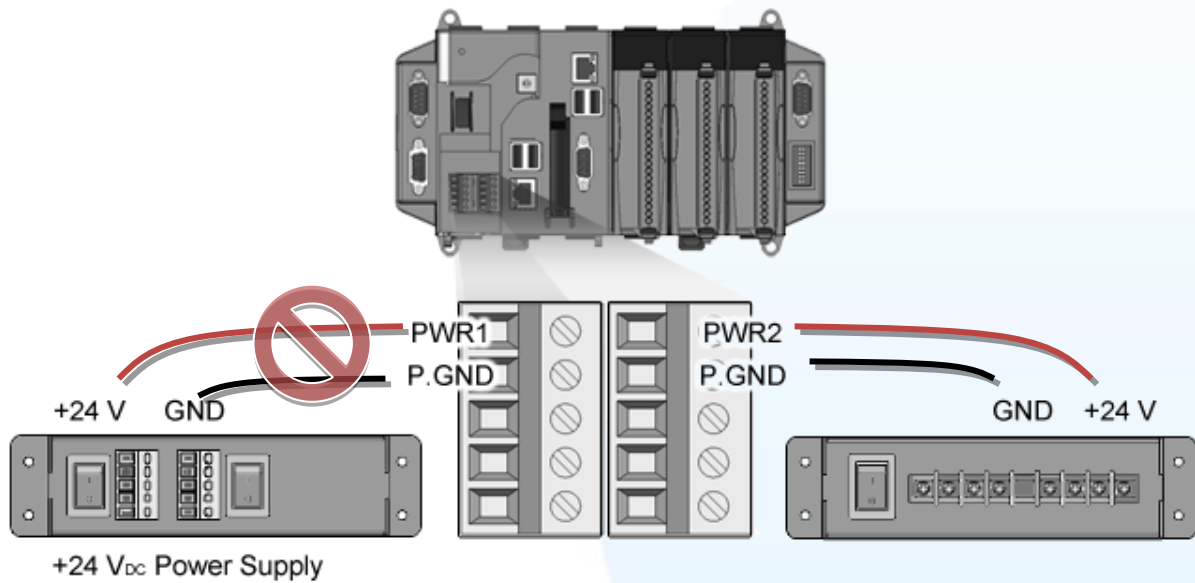

## Step 2 Check the boot status

After supplying the power to the unit, turn on the power. Here please note the four LED statuses to make sure the boot is correct. The boot process will take about 40~50 seconds.

i. Switch the power switch to the on position

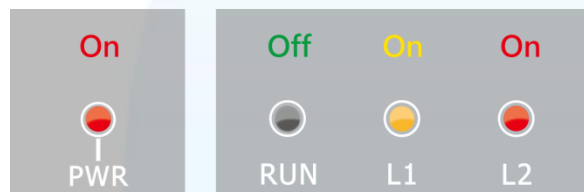
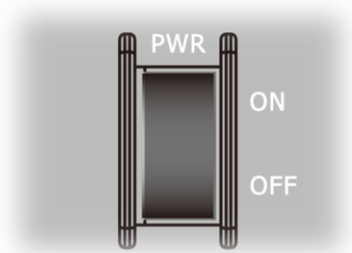

After waiting 2.5 seconds, the RUN LED indicator will be on

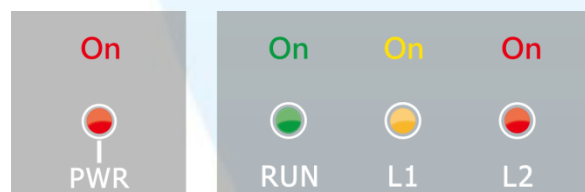

ii. Load BIOS

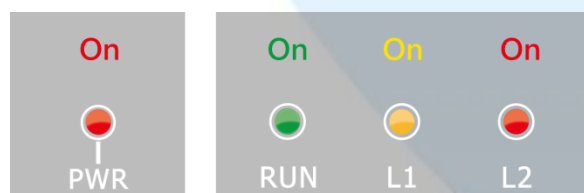

iii. Enter the welcome screen

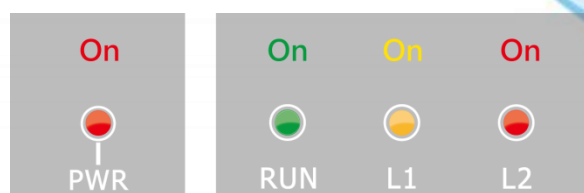

---

iv. Start to load OS



---

v. OS load successfully

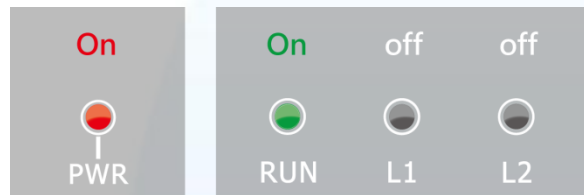

---

vi. The boot process has been finished successfully.

---

### Tips & Warnings



After the boot process has been finished, the L1 and L2 LED indicators will be released. The user can use XPAC API to control them.

## 2.2. Installing the Tools and Utilities

The XP-8000-Atom-CE6 has several tools and utility that allows and supports you quickly and easily to manage the XP-8000-Atom-CE6. Here we will introduce two practical of them and guide you through the installation.



cerhost.exe

interface.

**Remote Display** is one of the Windows CE operating system toolkits. If your XP-8000-Atom-CE6 is connected to PC through the network, you can use this utility to display the device screen on the host PC and control the XP-8000-Atom-CE6 remotely through this

interface. For more information on how to use Remote Display to control the XP-8000-Atom-CE6 remotely, please refer to section 2.6. Using Remote Display to Control the XP-8000-Atom-CE6 Remotely.



DCON\_Utili...

DCON Utility is a toolkit that is designed to configure, manage and monitor the I/O modules from PC via COM port or Ethernet.

For more information on how to use DCON Utility to configure the I/O module, please refer to section 2.7. Using DCON Utility to Configure the I/O Module.

### Step 1 Get the DCON Utility and Remote Display

The DCON Utility and Remote Display can be installed from the CD that was provided with the package or by downloading the latest version from ICP DAS web site.

CD:\XPAC-ATOM-CE6\PC\_Tools

[ftp://ftp.icpdas.com/pub/cd/xpac-atom-ce6/pc\\_tools/](ftp://ftp.icpdas.com/pub/cd/xpac-atom-ce6/pc_tools/)

### Step 2 Follow the prompts until the installation is complete



## 2.3. Configuring the Boot Mode

The XP-8000-Atom-CE6 has the following main operating modes, which can be selected by a rotary switch.



Rotary Switch Position	Operating Mode
0	Normal mode (Default)
1	Safe mode
2~7	(For user defined mode)
8	DCON_CE mode
9	Remote Display mode

The following is a brief introduction of these modes.

### Normal Mode (Default mode)

Normal mode is the default mode of operation and the one you will use most of the time. Use this mode for more tasks and configurations. Programs also are executed in this mode.

### Safe Mode

Safe mode is a trouble shooting. All settings will be set to factory default on this mode.

If you have malicious software or a program caused the XP-8000-Atom-CE6 cannot be boot or run the normal mode, you can boot in safe mode to solve the problem.

### DCON\_CE

In this mode, the VCEP will be run automatically, and other settings are same as the normal mode.

For more information about the DCON CE, please refer to section 3.1.1. DCON CE.

## **Remote Display**

In this mode, the cerdisp.exe will be run automatically, and other settings are same as the normal mode.

For more information about the Remote Display, please refer to section 2.6. Using Remote Display to Control the XP-8000-Atom-CE6 Remotely.

## **User Mode**

The positions 2, 3, 4, 5, 6, 7 of rotary switch are reserved for user's applications.

When XP-8000-Atom-CE6 is boot with one of these positions, it is boot at normal mode. User's application can check the rotary switch position to run at different mode.

## 2.4. Changing the User Interface Language

The "Regional Settings" is a Windows CE functionality that allows users to easily change the XP-8000-Atom-CE6 user interface to your native language.

Here are step by step instructions on how to change the XP-8000-Atom-CE6 user interface language.

### Step 1 Click Start menu, point to Settings, click Control Panel, and then click Regional Options

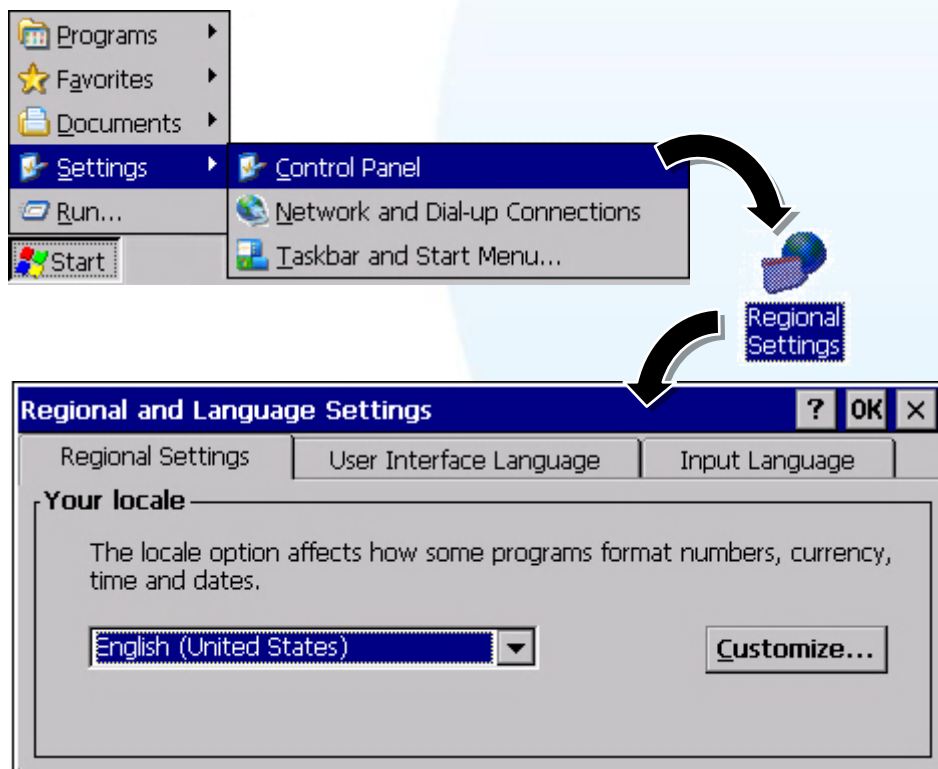

**Step 2** Click **User Interface Language** tab, choose to your local language, and then click **OK**

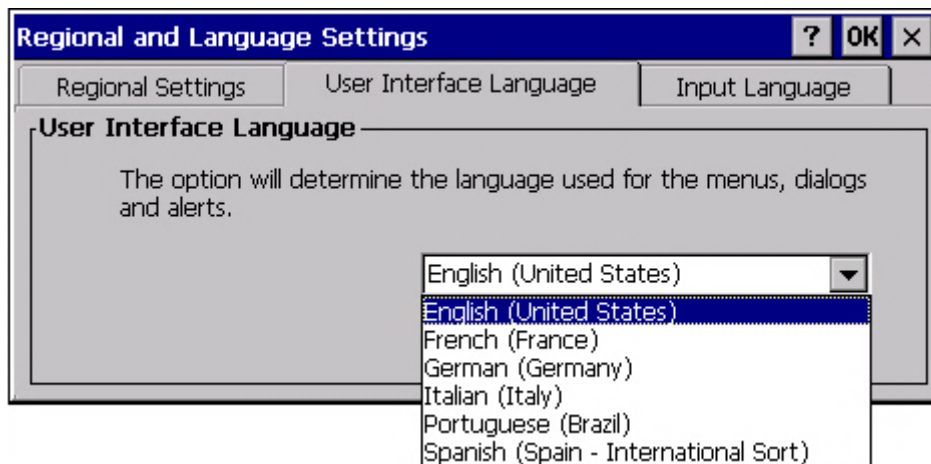

**Step 3** Click **OK**, and then reboot **XP-8000-Atom-CE6** for changes to take effect

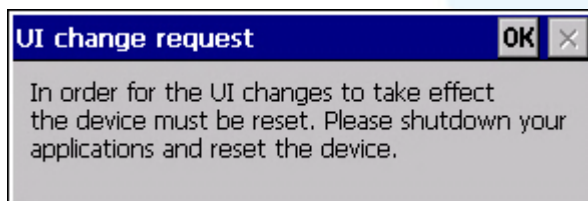

## 2.5. Using XPAC Utility to Configure XP-8000-Atom-CE6 Basic Functionality

The XPAC Utility is a collection of the XP-8000-Atom-CE6 system tool that allows user quickly and easily manage and configure the XP-8000-Atom-CE6.

Here are step by step instructions on how to use XPAC Utility to configure XP-8000-Atom-CE6 basic functionality.

### Step 1 Run the XPAC Utility

### Step 2 Configure IP(DHCP), FTP Server, Auto Execution..., etc

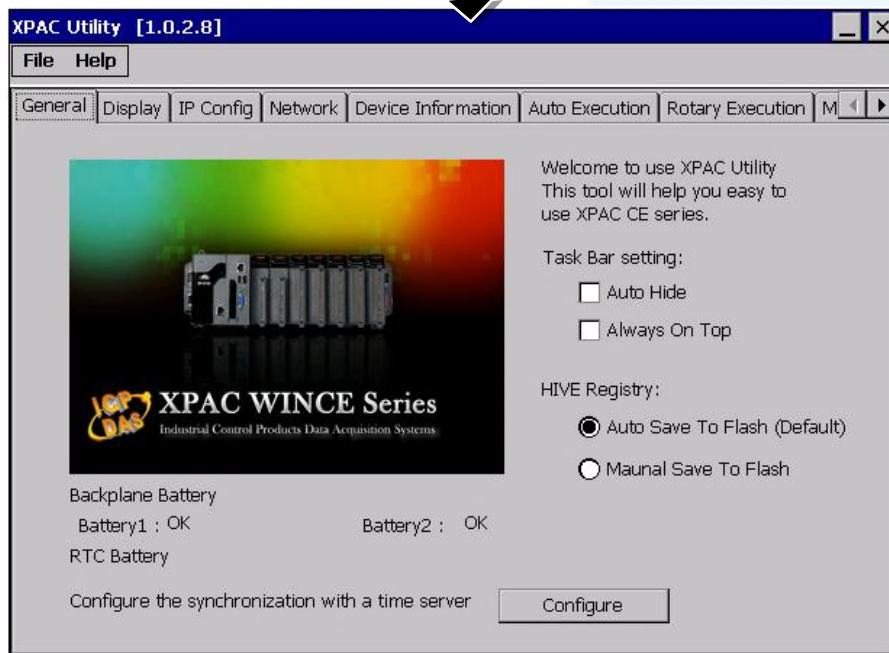
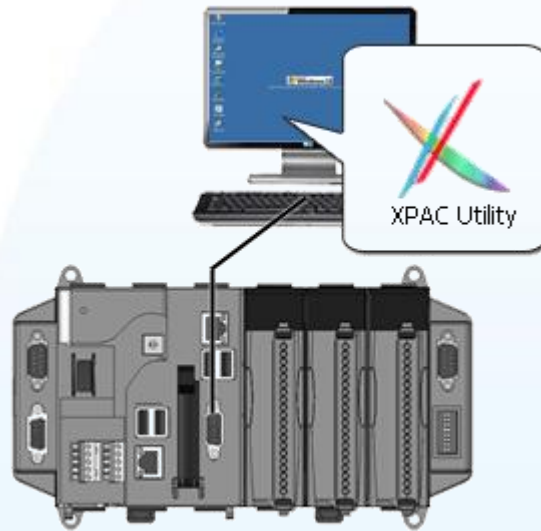

For more information about the XP-8000-Atom-CE6 basic functionality, please refer to section 3.1.10. XPAC Utility.

## 2.6. Using Remote Display to Control the XP-8000-Atom-CE6 Remotely

The "Remote Display" is a Windows CE functionality that allows XP-8000-Atom-CE6 to be controlled and monitored from a remote location. This tool is composed of two parts, a client and a server. The server is a program named cerdisp.exe running on XP-8000-Atom-CE6. The client is a PC-based program named cerhost.exe running on the PC.

Here are step by step instructions on how to use Remote Display to control XP-8000-Atom-CE6 remotely.

### Step 1 On PC side, click client program, cerhost.exe

The Remote Display can be installed from the CD that was provided with the package or by downloading the latest version from ICP DAS web site.

CD:\XPAC-ATOM-CE6\PC\_Tools\Remote\_Display\

[ftp://ftp.icpdas.com/pub/cd/xpac-atom-ce6/pc\\_tools/remote\\_display/](ftp://ftp.icpdas.com/pub/cd/xpac-atom-ce6/pc_tools/remote_display/)



### Step 2 On XPAC side, click server program, cerdisp.exe

The cerdisp.exe are pre-installed on the XP-8000-Atom-CE6, located under \System\_Disk\Tools\Remote\_Display

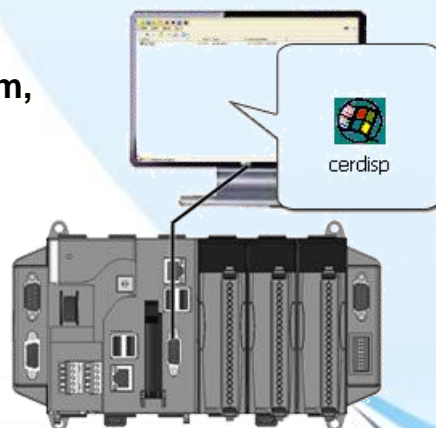

**Step 3** Click OK button, click Connect button, type the IP address of the host PC

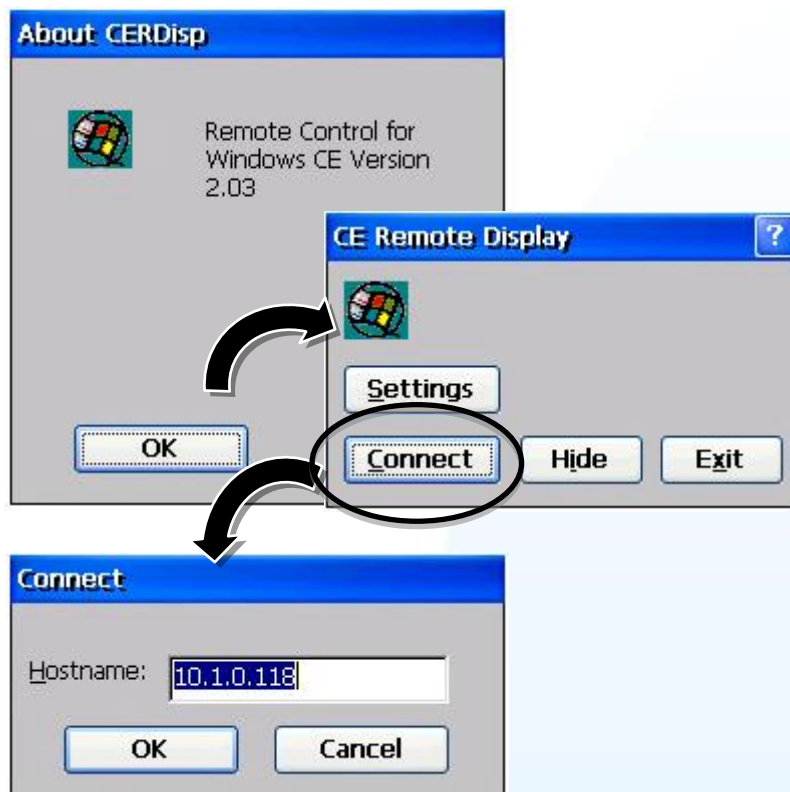

**Step 4** The remote connection has been established

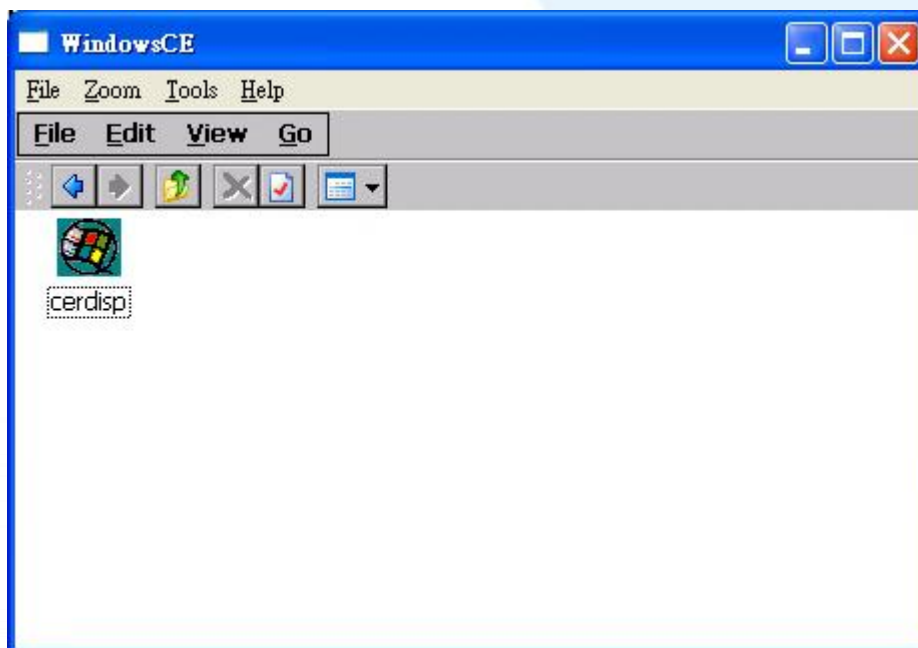



## 2.7. Using DCON Utility to Configure the I/O Module

The DCON Utility is a client utility that runs on PC, and communicates with XP-8000-Atom-CE6 via DCON protocol. The DCON Utility allows users to remotely connect to I-7K and I-87K series I/O modules for management through the COM port and Ethernet port.

This tool is composed of two parts, a client and a server. The server is a program named DCON\_CE\_Vxxx running on XP-8000-Atom-CE6. The client is a PC-based program named DCON Utility running on the PC.

Here are step by step instructions on how to use DCON Utility to configure the I/O modules.

### Step 1 On XPAC side, click server program, DCON\_CE\_Vxxx

The DCON\_CE\_Vxxx are pre-installed on the XP-8000-Atom-CE6, located under \System\_Disk\Tools\DCON\_CE

#### Tips & Warnings



Please remember the port number appearing in the right-hand window. Sometimes XP-8000-Atom-CE6 will block a port through the firewall. You can use this information to open these ports so you can use certain applications.

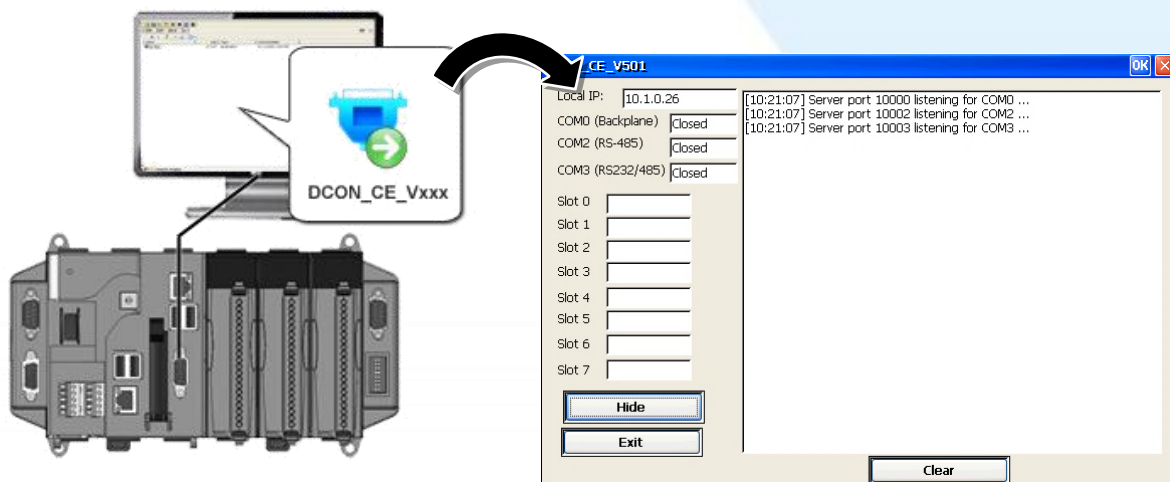



## Step 2 On PC side, Run the DCON Utility

The DCON Utility can be installed from the CD that was provided with the package or by downloading the latest version from ICP DAS web site.

CD:\XPAC-ATOM-CE6\PC\_Tools\DCON\_Utility\

[ftp://ftp.icpdas.com/pub/cd/xpac-atom-ce6/pc\\_tools/dcon\\_utility/](ftp://ftp.icpdas.com/pub/cd/xpac-atom-ce6/pc_tools/dcon_utility/)

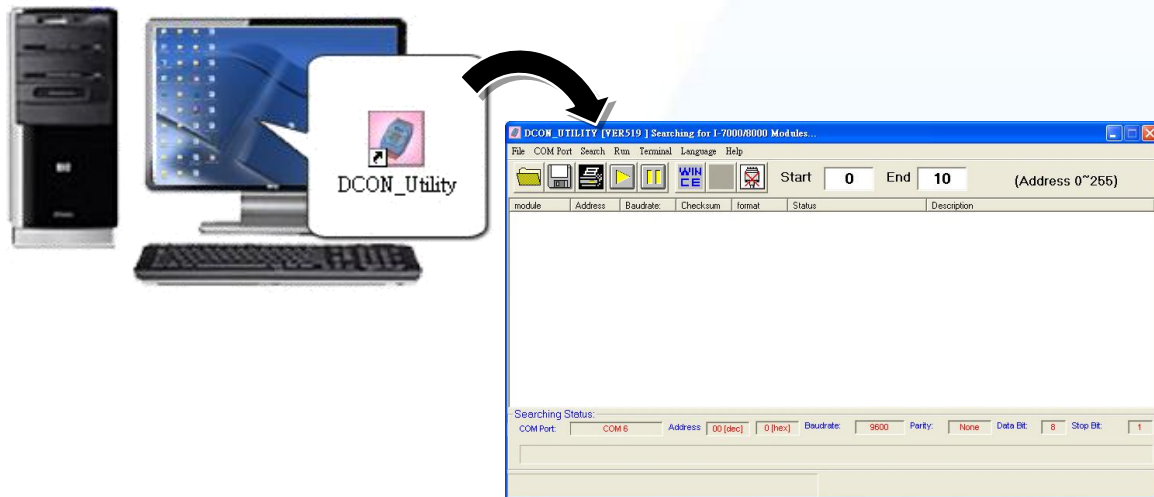

## Step 3 Click WINCE common button

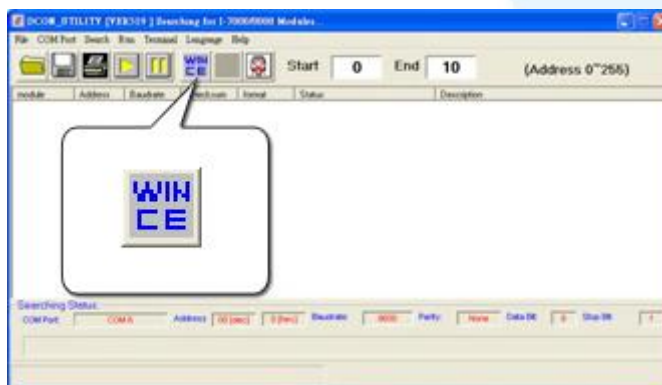

**Step 4** Click XPAC\_CE tab, type the IP address of the XPAC, and then click Connect to XPAC\_CE button

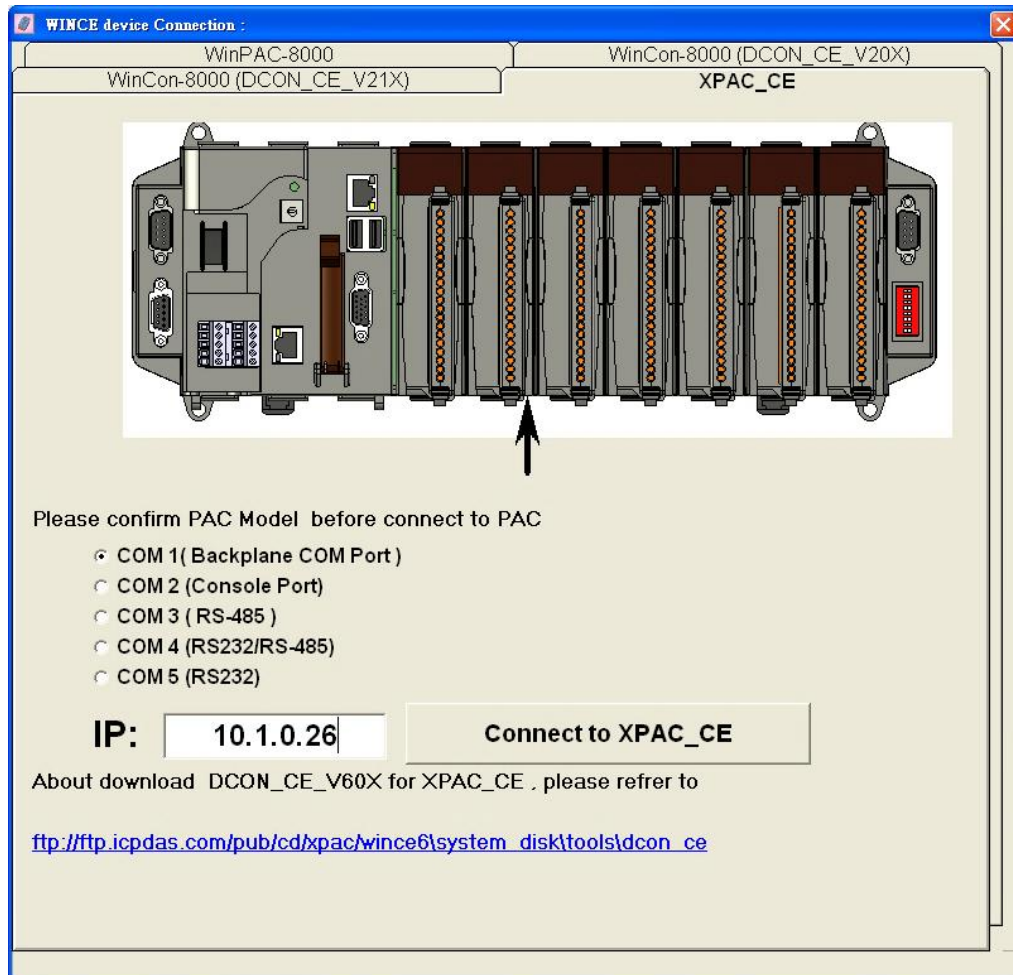

### Tips & Warnings



If DCON Utility cannot connect to XP-8000-Atom-CE6, the Ethernet connection between Host PC and XP-8000-Atom-CE6 might be rejected by fire wall, please contact with MIS to open the Ethernet port.

**Step 5** Click on the module name from the list to configure the settings form

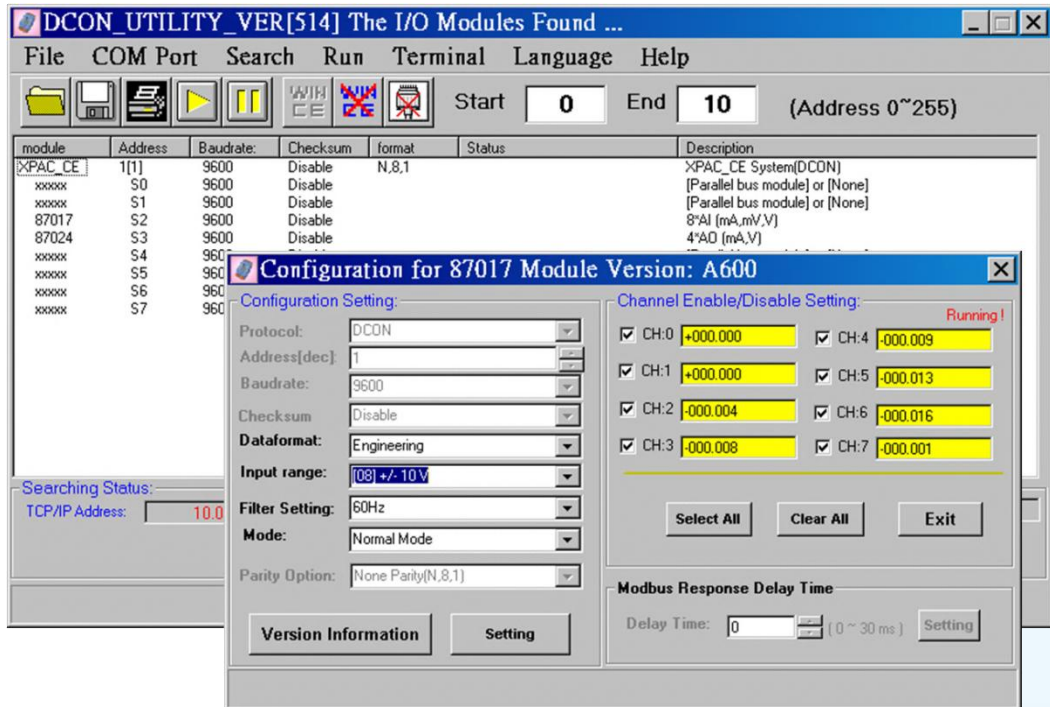

**Tips & Warnings**



If there is no operation within 30 seconds, the connection will automatically close to release the COM port occupied.



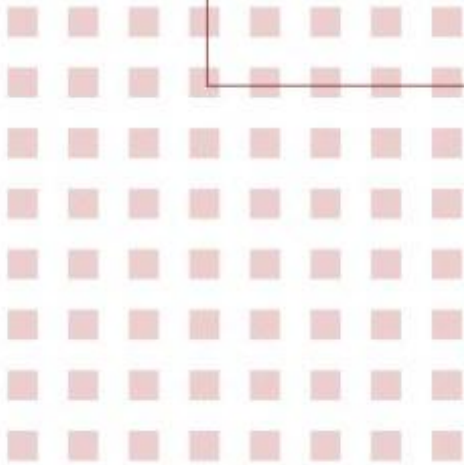
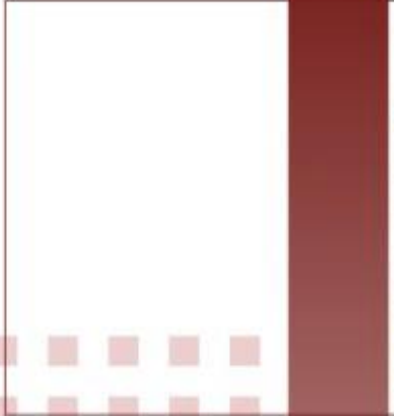

### 3. Tools and Tasks

This chapter provides information of the XP-8000-Atom-CE6 and its components that introduces the fundamental concepts for user familiar with the XP-8000-Atom-CE6.

There are several tools and utilities built-in and designed for use with the XP-8000-Atom-CE6. Some of these tools and utilities are installed on the XP-8000-Atom-CE6 controller, some are available on PC.

Both the XP-8000-Atom-CE6 side and PC side tools and utilities can be found separately on the CD that was provided with the package or by downloading the latest version from ICP DAS web site.

### Tools and Utilities on XPAC

CD:\XPAC-ATOM-CE6\System\_Disk\Tools\

[ftp://ftp.icpdas.com/pub/cd/xpac-atom-ce6/system\\_disk/tools/](ftp://ftp.icpdas.com/pub/cd/xpac-atom-ce6/system_disk/tools/)

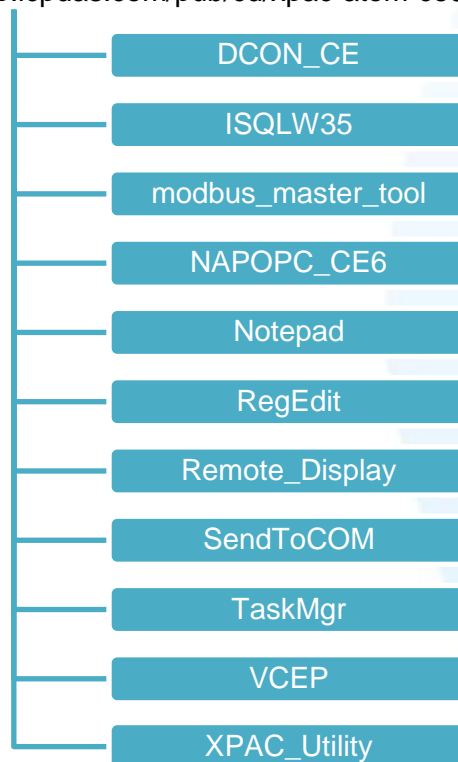

### Tools and Utilities on PC

CD:\XPAC-ATOM-CE6\PC\_Tools\

[ftp://ftp.icpdas.com/pub/cd/xpac-atom-ce6/pc\\_tools/](ftp://ftp.icpdas.com/pub/cd/xpac-atom-ce6/pc_tools/)

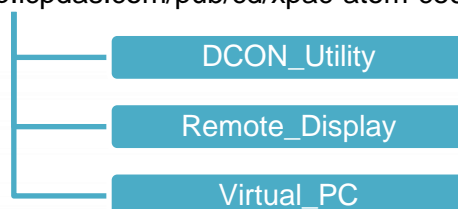

## 3.1. Tools and Tasks on XPAC

### 3.1.1. DCON\_CE

The DCON\_CE is a server program based that runs on XP-8000-Atom-CE6, and communicates with PC via DCON protocol.

The DCON Utility is a client utility that runs on PC, and communicates with XP-8000-Atom-CE6 via DCON protocol. The DCON Utility allows users to remotely connect to I-7K and I-87K series I/O modules for management through the COM port and Ethernet port.

This tool is composed of two parts, a client and a server. The server is a program named DCON\_CE\_Vxxx running on XP-8000-Atom-CE6. The client is a PC-based program named DCON Utility running on the PC.

## 3.1.2. ISQLW35

The "ISQLW35" is a Windows CE functionality that implements SQL Server Compact 3.5 Query

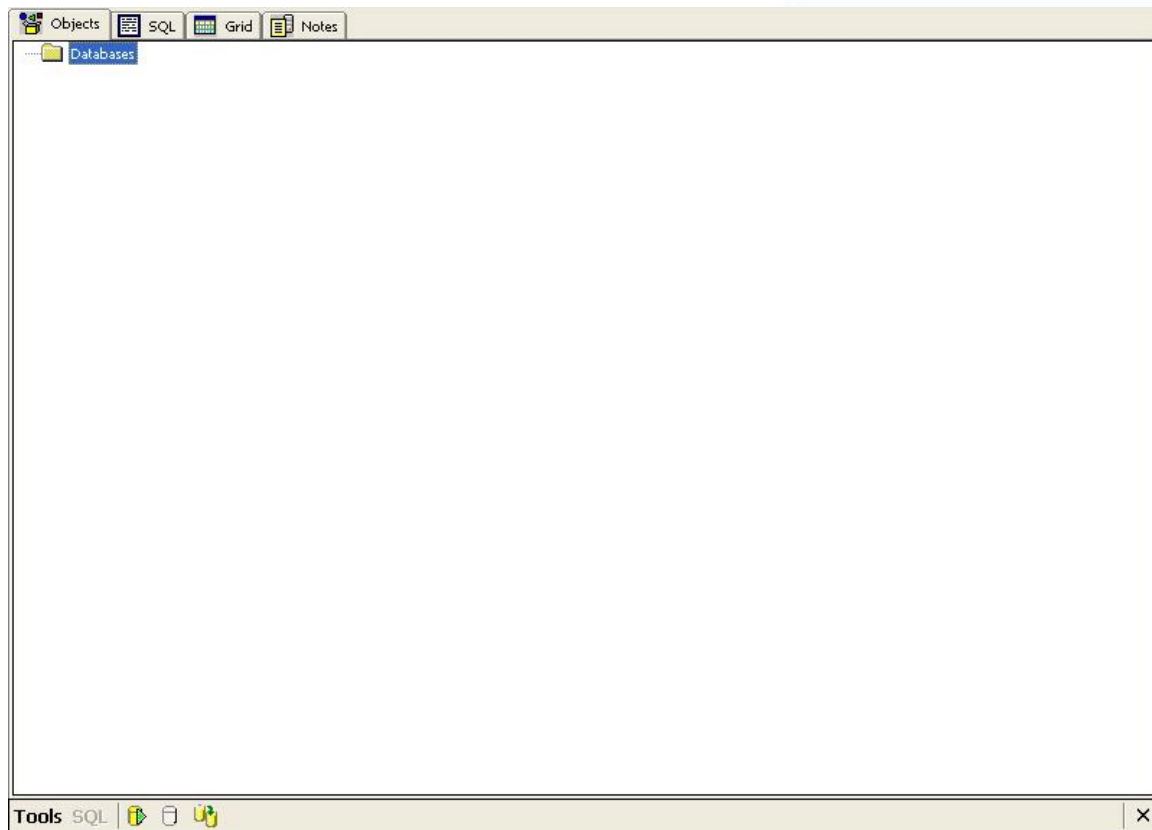



### 3.1.3. modbus\_master\_tool

Modbus\_VB.NET\_Demo Default ID:1

Modbus TCP/RTU(Checked:TCP UnChecked:RTU)

COM Port: 1 Baudrate: 19200 Create

IP Address: 10.0.0.80 Timeout: 500

Address 6~10  
0 0 0 0 0 RCoils

Address 16~20  
0 0 0 0 0 RRegs

Write Address: 7 Value: 1 WCoil

Write Address: 16 Value: 12345 WReg



### 3.1.4. NAPOPC\_CE6



**NAPOPC\_CE6** DA Server is a free OPC DA Server (The "OPC" stands for "OLE for Process Control" and the "DA" stands for "Data Access") working on XPAC, ViewPAC & WinPAC controllers provided by ICP DAS Ltd. The first standard (originally called simply the OPC Specification and now called the Data Access

Specification) resulted from the collaboration of a number of leading worldwide automation suppliers working in cooperation with Microsoft. Originally based on Microsoft's OLE COM (component object model) and DCOM (distributed component object model) technologies, the specification defined a standard set of objects, interfaces and methods for use in process control and manufacturing automation applications to facilitate interoperability. **NAPOPC\_CE6** DA Server integrates OPC, Modbus TCP Slave and Modbus RTU Slave three kind Slave services, as well as integrates Modbus TCP Master, Modbus RTU Master and DCON three kind Master communication protocols. It also provides one advanced function "Rule Script" for use in the I/O integration and transformation, and some conditional Logic operation.

## 3.1.5. INotepad

The INotepad is a Windows CE application, which is a common text-only editor. The resulting files have no format tags or styles, making the program suitable for editing system files that are to be used in a DOS environment.

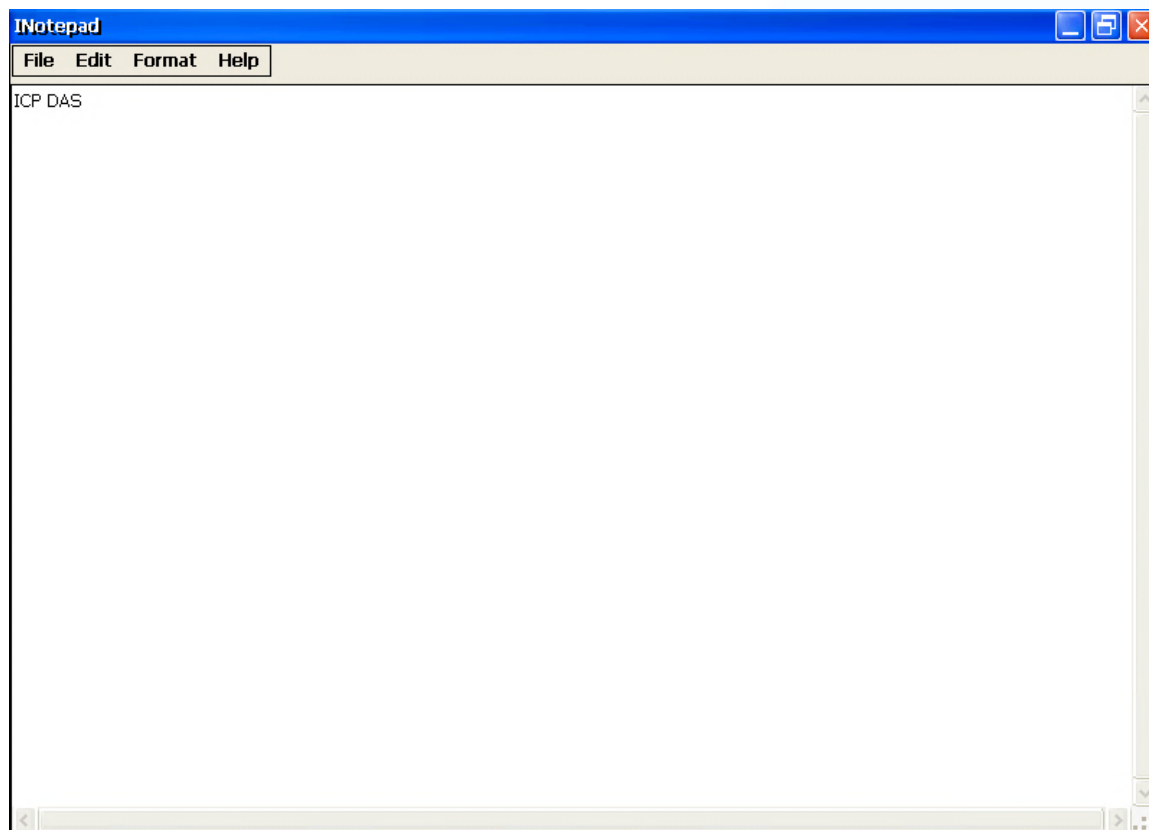

## 3.1.6. RegEdit

The RegEdit is a Windows CE application, which provides a hierarchical representation of the registry on a target computer, similar in appearance to the Windows Registry Editor. The standard registry roots are represented; you can add keys beneath a root to point to existing registry keys, or you can add your own keys. Values can be changed for existing keys, or added for new keys, and default keys can be specified. For more information, see Registry Settings Management in Deployment.

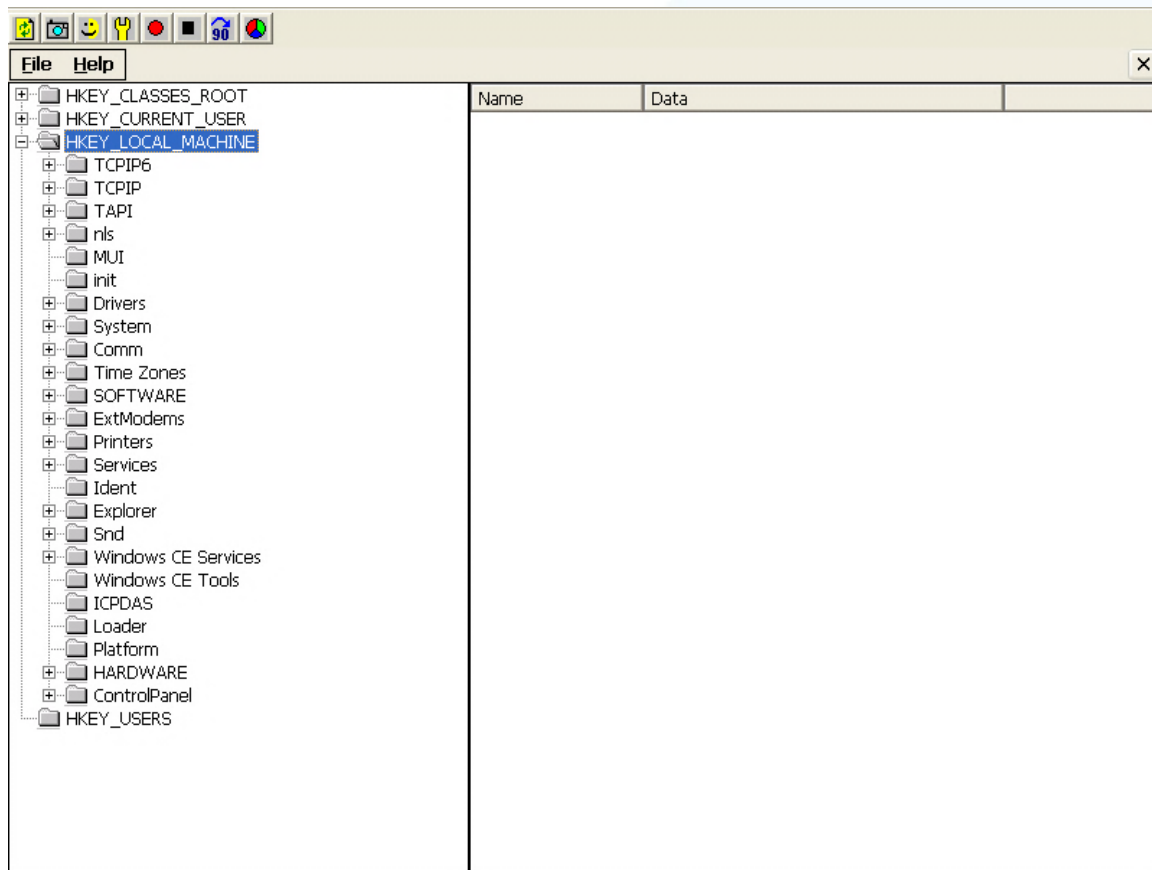

## 3.1.7. Remote\_Display

The "Remote Display" is a Windows CE functionality that allows XP-8000-Atom-CE6 to be controlled and monitored from a remote location. This tool is composed of two parts, a client and a server. The server is a program named cerdisp.exe running on XP-8000-Atom-CE6. The client is a PC-based program named cerhost.exe running on the PC.

For more information on how to use remote display to control the XP-8000-Atom-CE6 remotely, please refer to section 2.6. Using Remote Display to Control the XP-8000-Atom-CE6 Remotely.

## 3.1.8. Send ToCOM

The SendToCOM uses the serial port to communicate with expansion module. To use the SendToCOM, you can send data to expansion module through the serial port, and receive data from other device through the serial port.

For more information about these commands for communicating with expansion module, please refer to:

CD:\Napdos\io\_module\87k\_high\_profile\_modules.htm

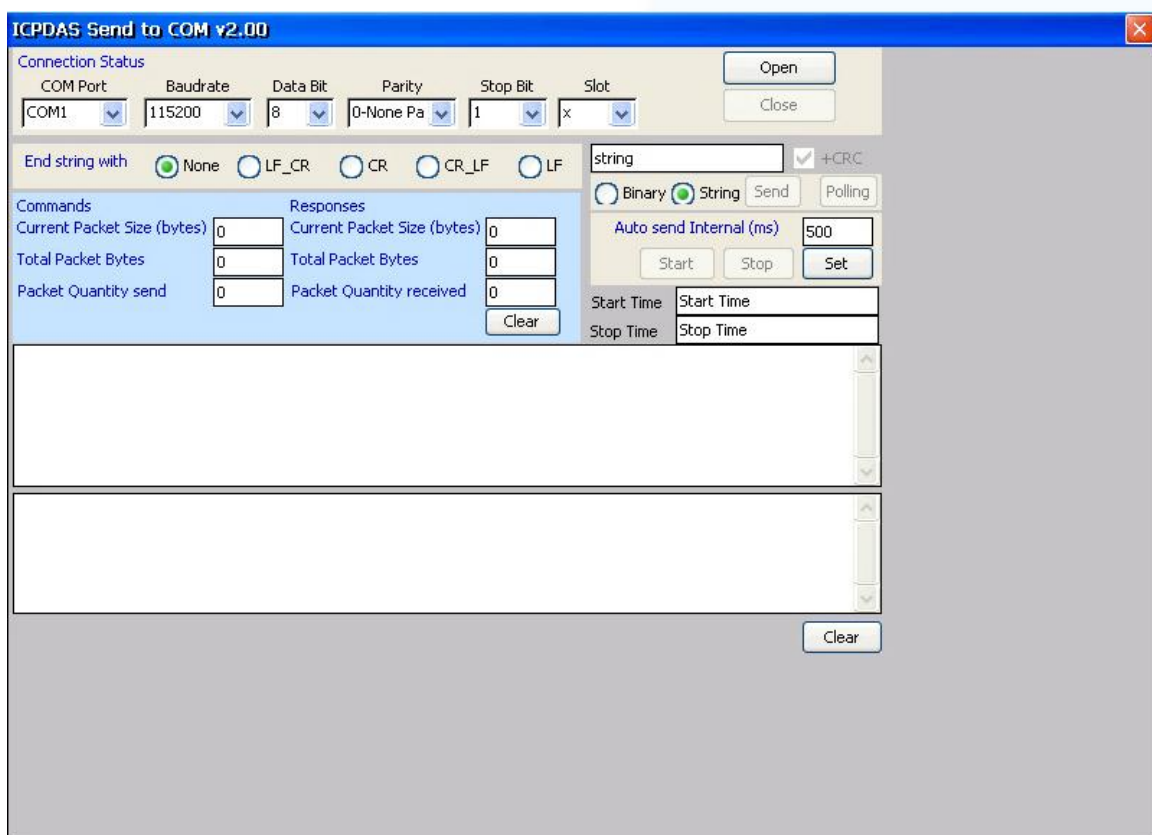

### 3.1.9. TaskMgr

The TaskMgr is a Windows CE application, which provides real time info on all processes and threads including System threads, similar in appearance to the Windows Task Manager.

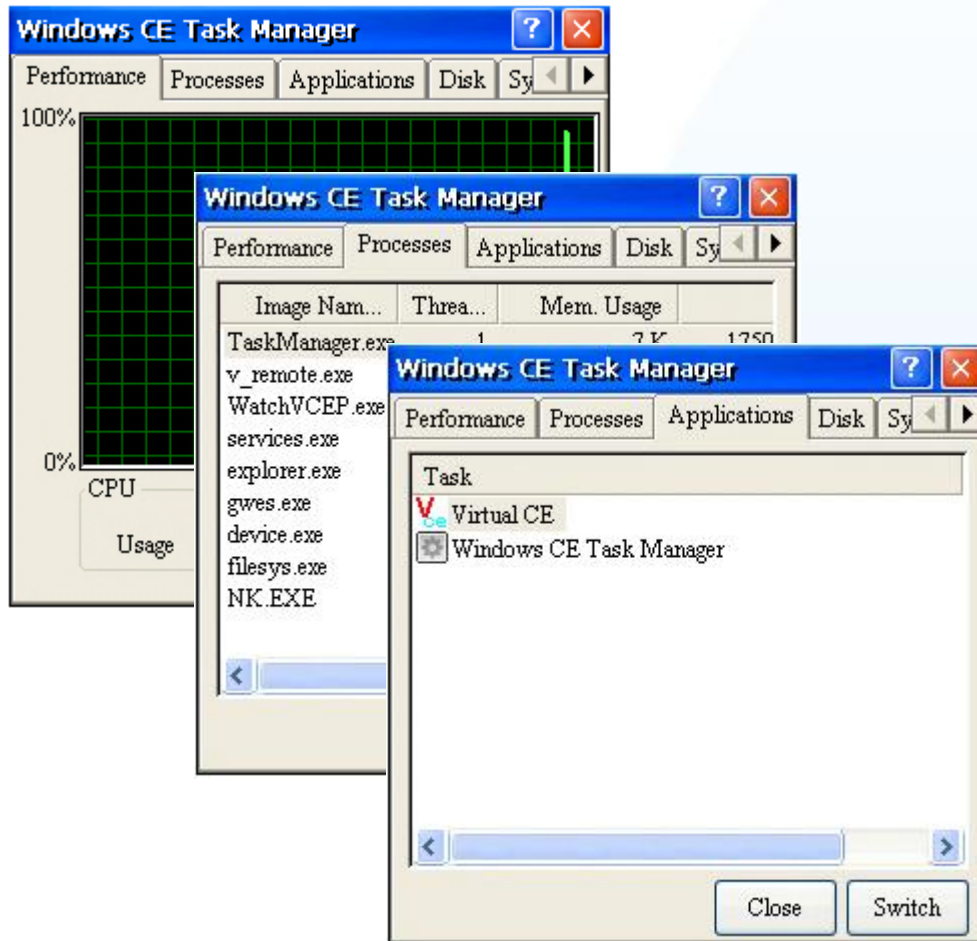

## 3.1.10. XPAC\_Utility

XP-8000-Atom-CE6 Utility is a collection of software applications that enable management and configuration of XP-8000-Atom-CE6 system and features.

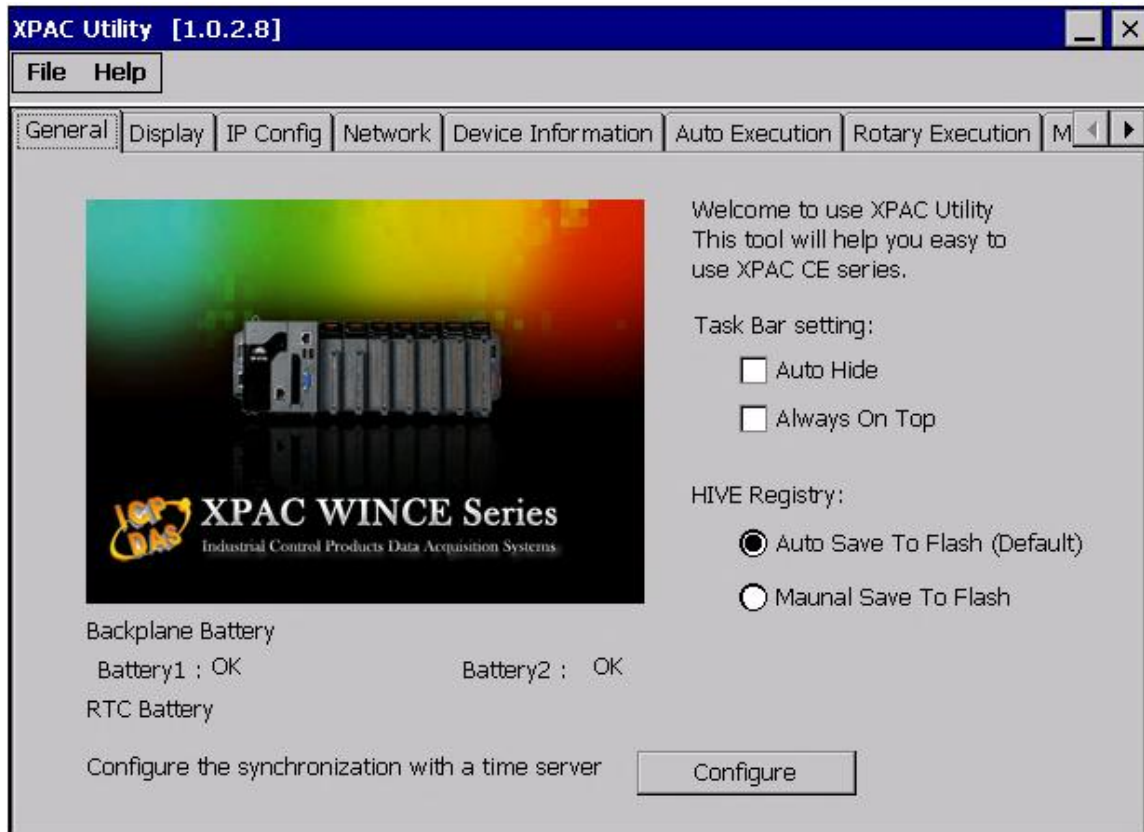

### 3.1.10.1. Menu Bar

The XPAC Utility includes the following function menu. All function menus will be explained later.

#### ► File menu

---

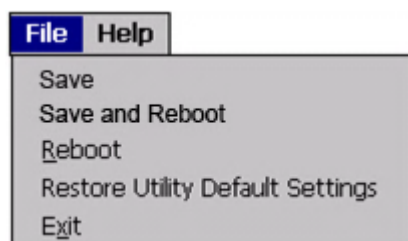

The menu commands	Used to
Save	Saves the settings into Flash. The new settings don't take effect until the XPAC restart.
Save and Reboot	Saves the settings into Flash and restart the XPAC. The new settings will take effect after the XPAC restart.
Reboot	Restart the XPAC
Restore Utility Default Settings	Restore the settings of XPAC Utility to its default
Exit	Exit the XPAC Utility.



## ► Help menu

---

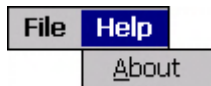

The menu commands	Used to
About	Display a dialog box with information about XPAC Utility, including the current version and copyright information.



## 3.1.10.2. Property Tabs

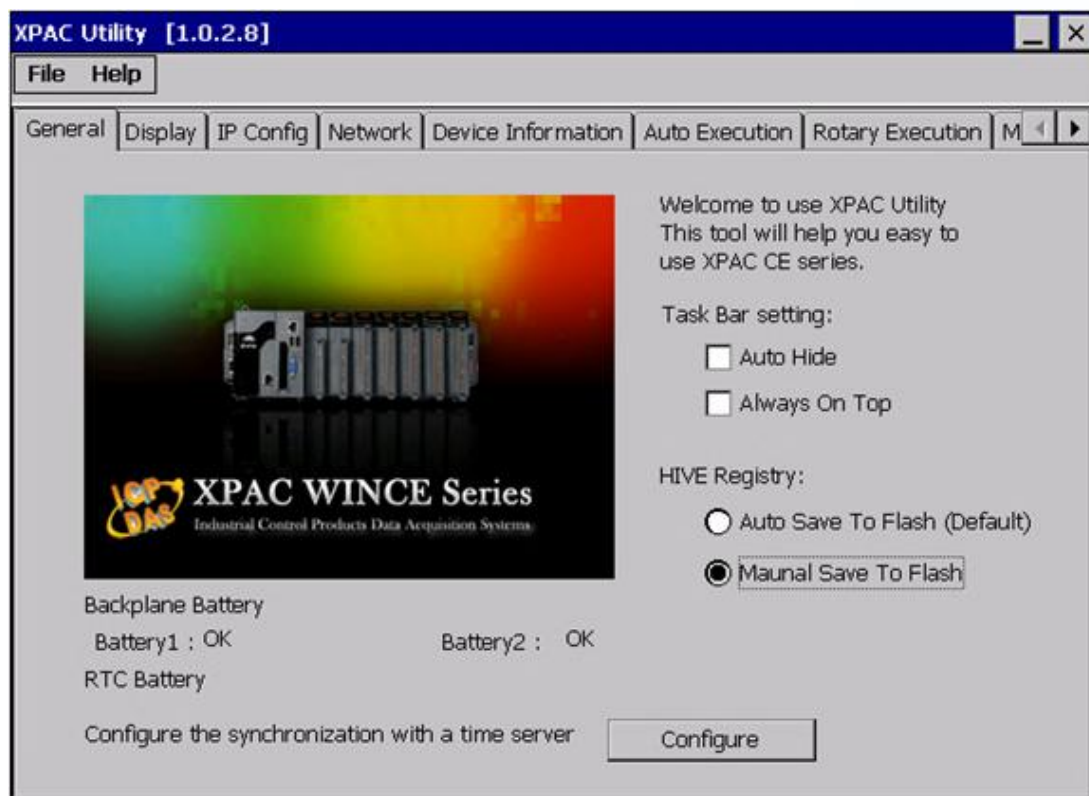

The XPAC Utility includes the following property tabs, all property tabs will be explained later.

- ↳ General
- ↳ Display
- ↳ IP Configure
- ↳ Network
- ↳ Device Information
- ↳ Auto Execution
- ↳ Rotary Execution
- ↳ Multi-IO Modules

## ➤ General tab

The System Setting tab provides functions to configure the task bar, HIVE registry and monitor RTC battery.

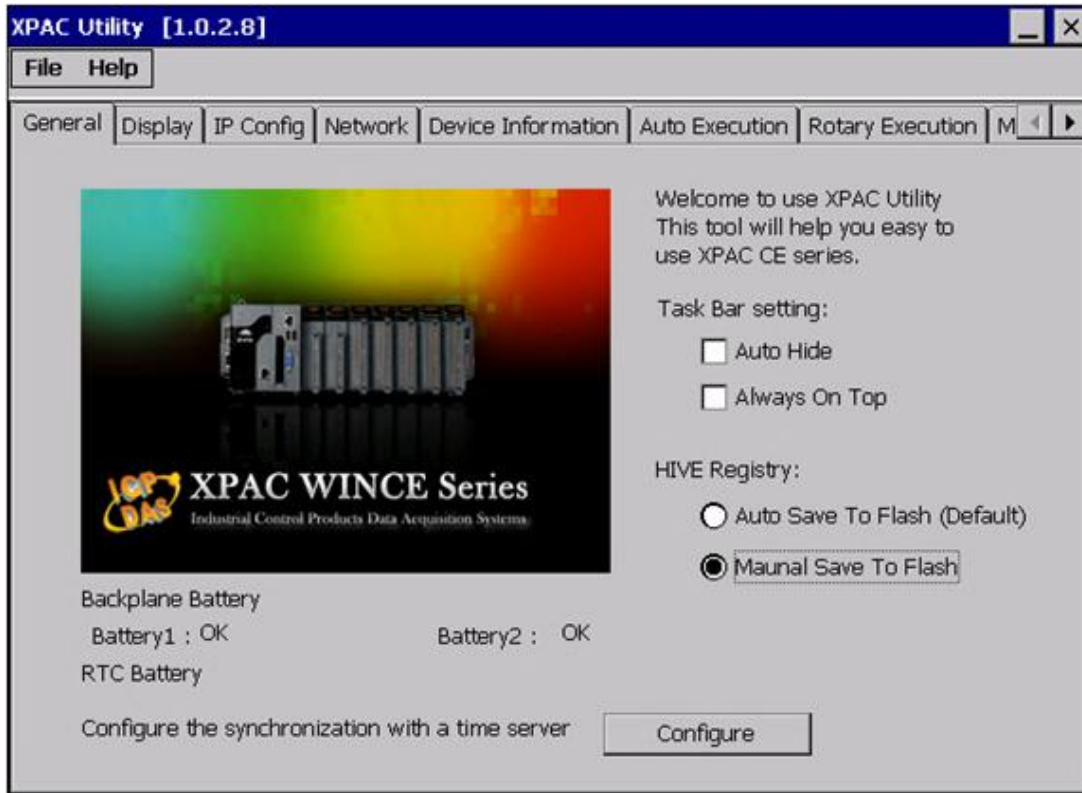

The tab use to	How to use
Lock or Auto-Hide the taskbar	Auto-Hide: Select the Auto Hide check box Lock: Select the Always On Top check box.
Auto or Manual save to Flash	Auto Save To Flash (Default): Select the Auto Save To Flash (Default) option Manual Save To Flash: Select the Manual Save To Flash option
Check the status of the battery	See the Battery1 and Battery2 field that displays the battery status.
Automatic synchronization of system time	Refer to the AppendixB.2 How to configure the service for automatically synchronizing with the internet time server

## ► Display tab

The Display tab provides functions to configure the monitor setting.

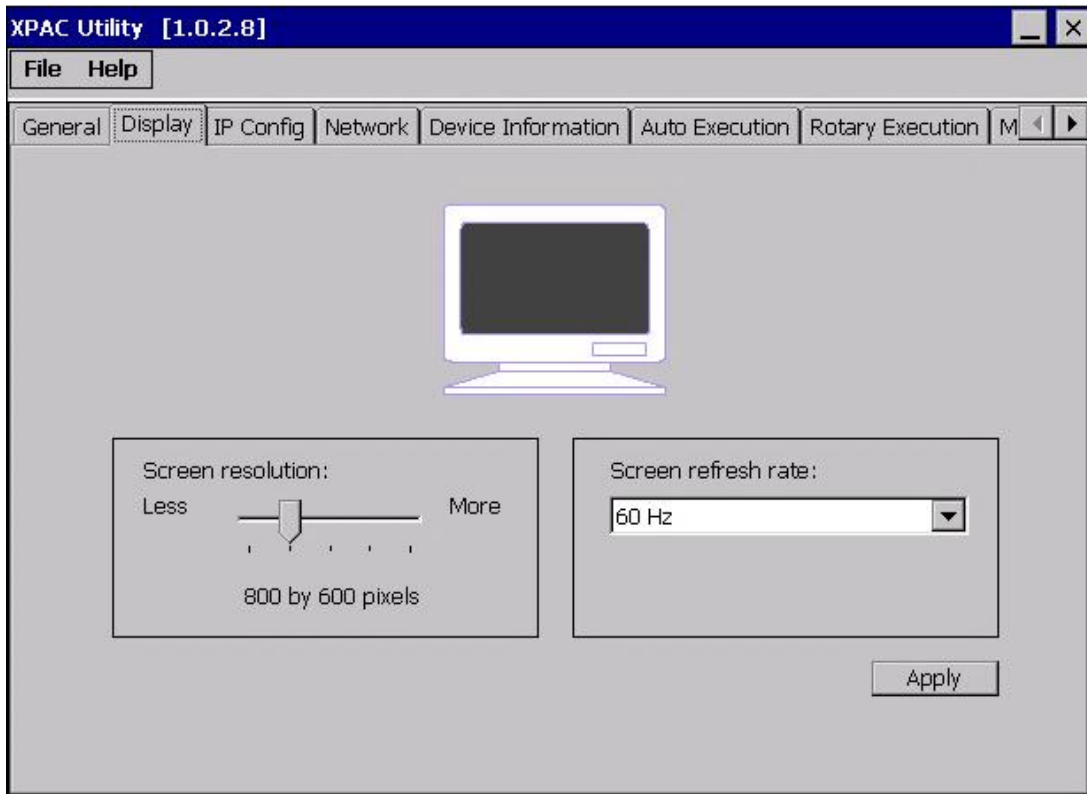

The tab use to	How to use
Adjust the screen resolution	Move the slider to the resolution you want, and then click apply button
Change the Screen Refresh Rate	Select a screen refresh rate, and then click apply button

## ► IP Config tab

The IP Config tab provides functions to configure either DHCP (Roaming) or manually configured (Static) network settings and to monitor the MAC address. Generally, DHCP is the default settings, but if you don't have a DHCP server, you must configure the network settings by using manual configuration.

**XPAC Utility [1.0.2.8]**

File Help

General Display **IP Config** Network Device Information Auto Execution Rotary Execution M ◀ ▶

**LAN 1:**

MAC Address: 00-90-FB-30-31-01

Use DHCP to get IP address

Assign IP address

IP Address:

Mask:

Gateway:

DNS Server:

Apply

**LAN 2:**

MAC Address: 00-0D-E0-12-45-23

Use DHCP to get IP address

Assign IP address

IP Address:

Mask:

Gateway:

DNS Server:

Apply

The tab use to	How to use
Check the MAC address	See the MAC Address 1 and MAC Address 2 fields that display the physical address of LAN1 and LAN2.
Configure the network settings	Obtaining an IP address automatically from DHCP: Select the Use DHCP to get IP address option.  Manually assign an IP address: Select the Assign IP address option.

## ➤ Network tab

---

The Network tab consists of two tabs, Access and Login, which provides functions to enable/disable the FTP access, enable/disable anonymous FTP access, configure the FTP directory path, change HTTP document root directory and maintain the FTP accounts.

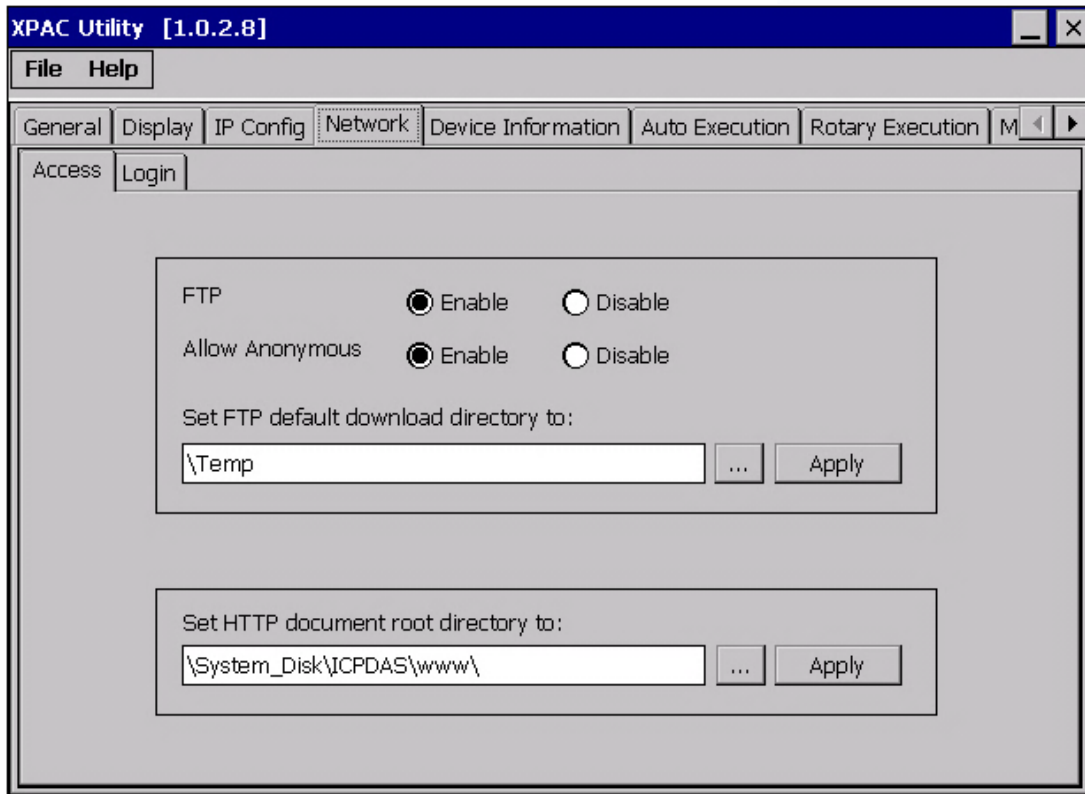

## Access tab

This tab provides functions to enable/disable the FTP access, enable/disable anonymous FTP access, configure the FTP directory path, and change HTTP document root directory.

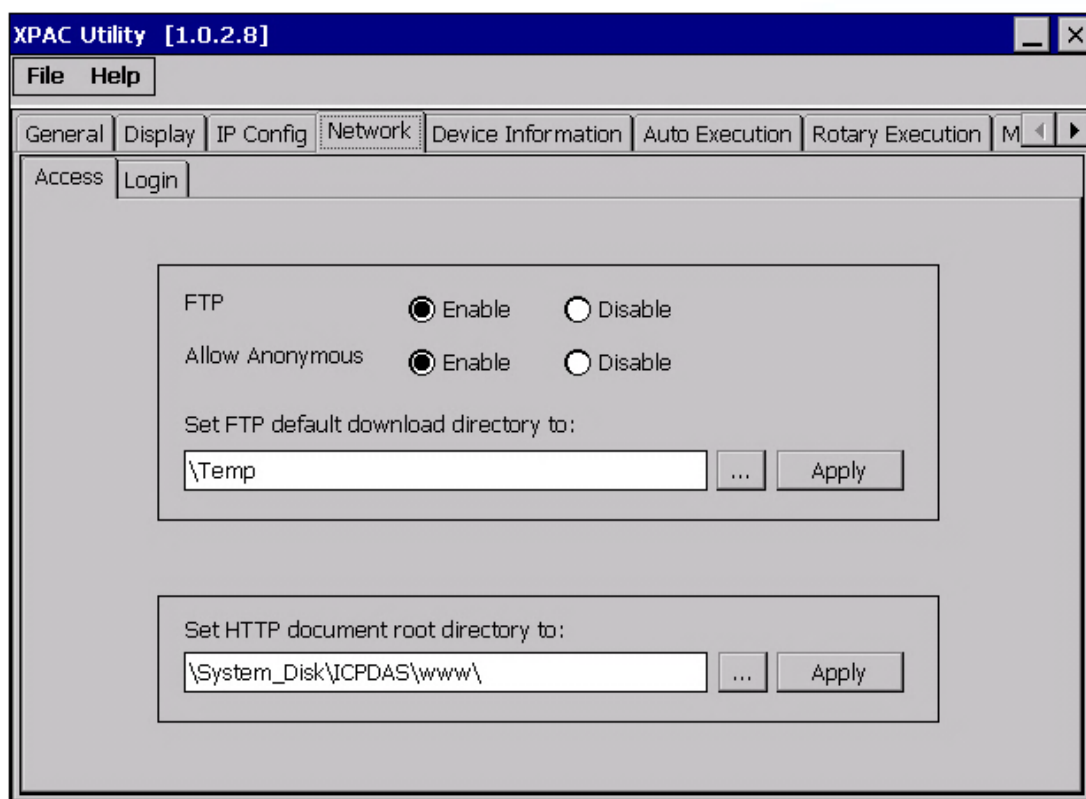

The tab use to	How to use
Enable/disable the FTP access	Enable: Select the Enable option Disable: Select the Disable option.
Enable/disable anonymous FTP access	Enable: Select the Enable option Disable: Select the Disable option.
Change the FTP directory path	Enter a new path in the Set FTP default download directory to field, and then press the Apply button.
Change the HTTP directory path	Enter a new path in the Set HTTP document root directory to field, and then press the Apply button.

## Login Access tab

This tab provides functions to maintain the FTP accounts.

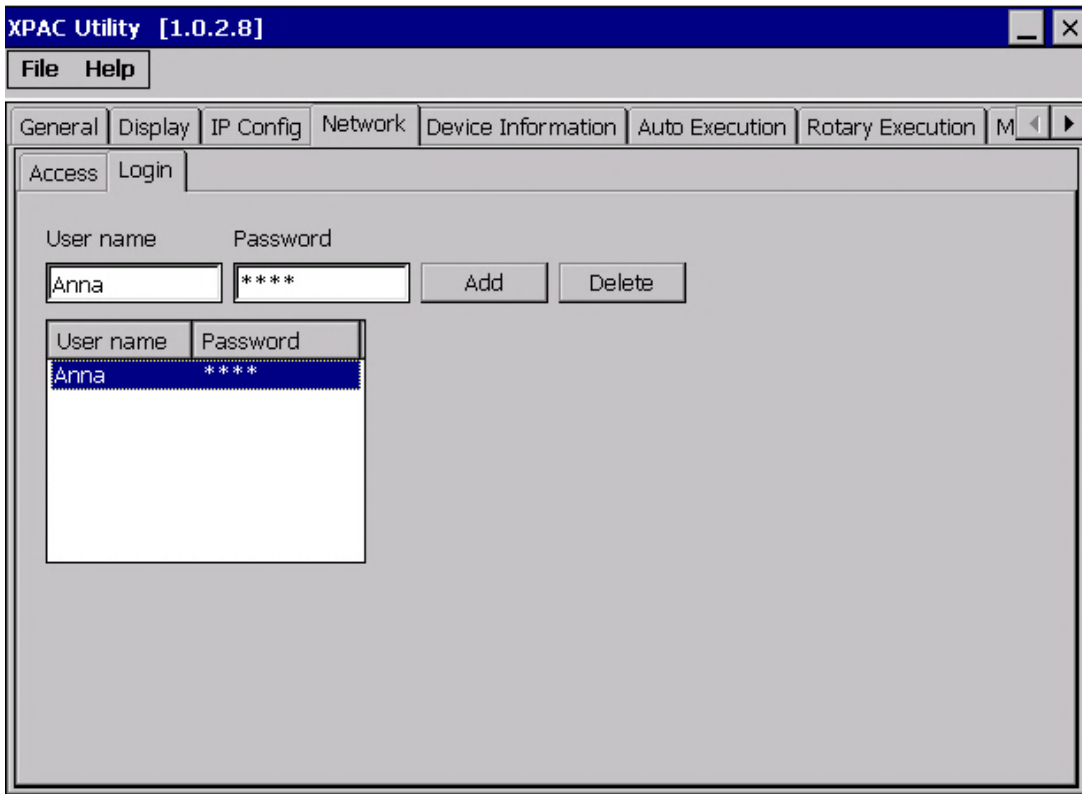

The tab use to	How to use
Maintain the FTP accounts	Refer to the AppendixB.3 How to add a user account to remote login the XPAC from PC.



## ➤ Device Information tab

---

The Device Information tab provides functions to monitor necessary device information of the XPAC. The system information is the most important note of version control for upgrading system.

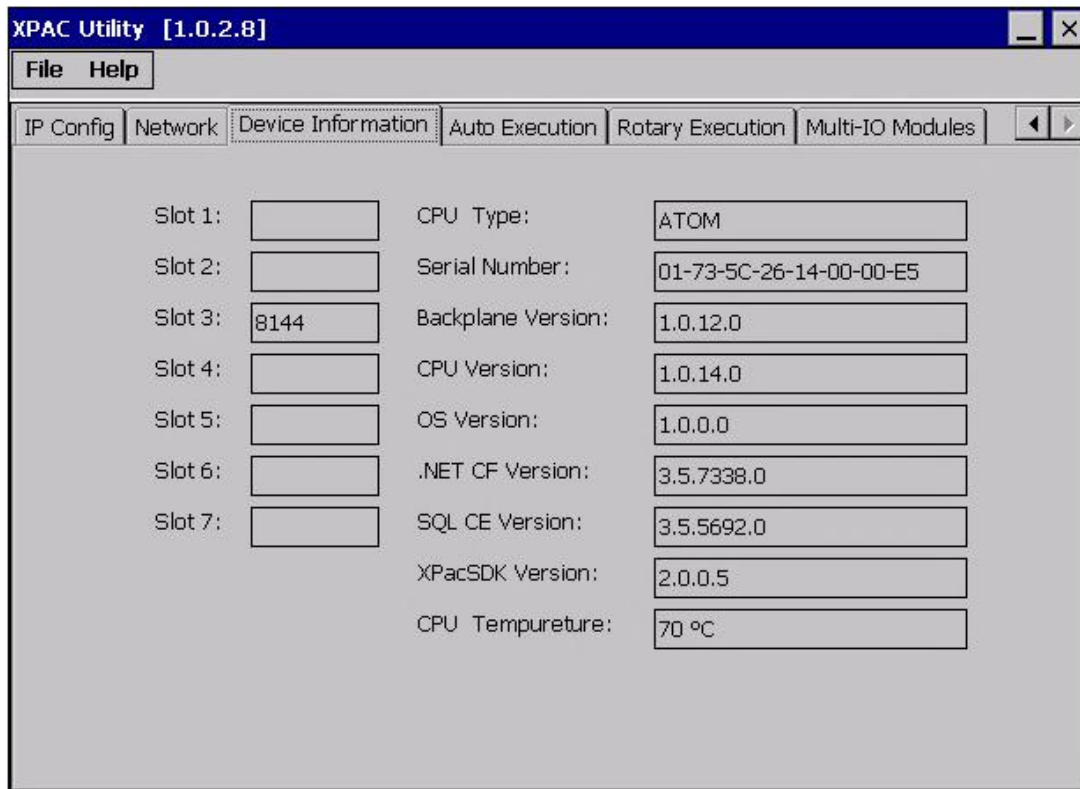

Slot 1:	<input type="text"/>	CPU Type:	<input type="text" value="ATOM"/>
Slot 2:	<input type="text"/>	Serial Number:	<input type="text" value="01-73-5C-26-14-00-00-E5"/>
Slot 3:	<input type="text" value="8144"/>	Backplane Version:	<input type="text" value="1.0.12.0"/>
Slot 4:	<input type="text"/>	CPU Version:	<input type="text" value="1.0.14.0"/>
Slot 5:	<input type="text"/>	OS Version:	<input type="text" value="1.0.0.0"/>
Slot 6:	<input type="text"/>	.NET CF Version:	<input type="text" value="3.5.7338.0"/>
Slot 7:	<input type="text"/>	SQL CE Version:	<input type="text" value="3.5.5692.0"/>
		XPacSDK Version:	<input type="text" value="2.0.0.5"/>
		CPU Temperature:	<input type="text" value="70 °C"/>

## ► Auto Execution tab

The Auto Execute tab provides functions to configure programs running at WinPAC startup, it allows users to configure ten execute files at most.

### Tips & Warnings



The allowed file types are .exe and .bat, and they are executed in order of program 1, program 2, etc.

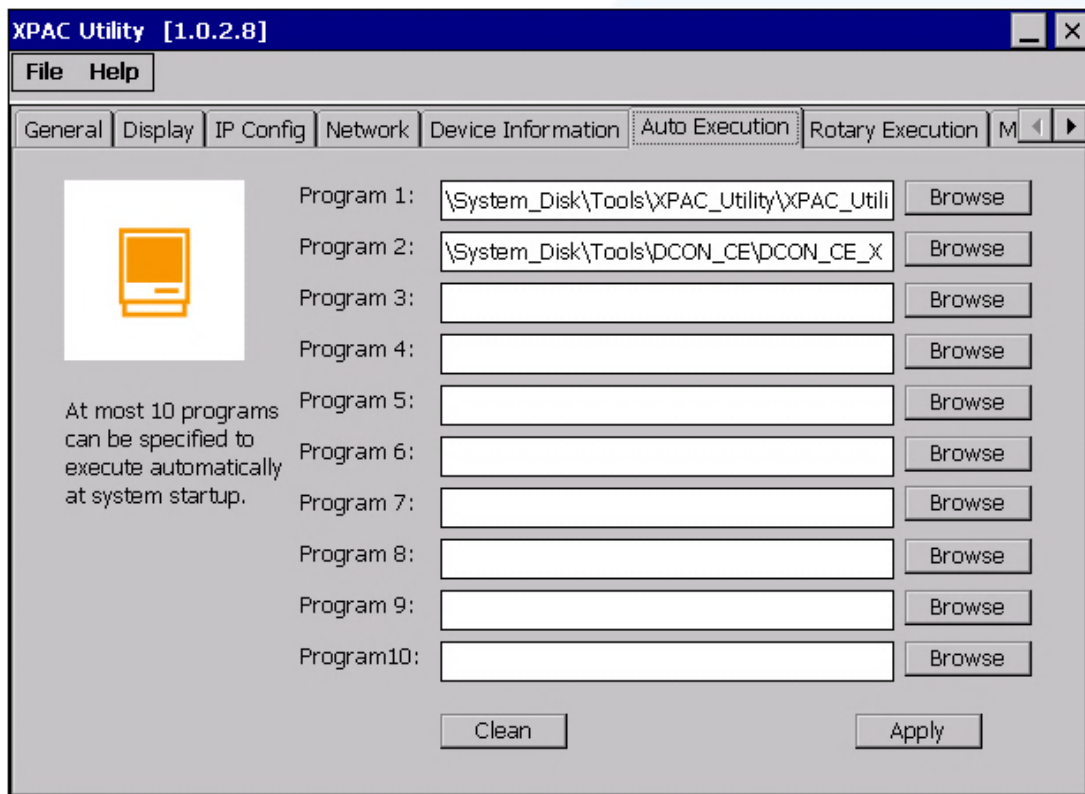

The tab use to	How to use
Configure programs running at startup	Press the Browse button to select the execute file which you want, and then press the Apply button.

## ➤ Rotary Execution tab

The Rotary Execution tab provides function to decide which mode XP-8000-Atom-CE6 executes at startup.

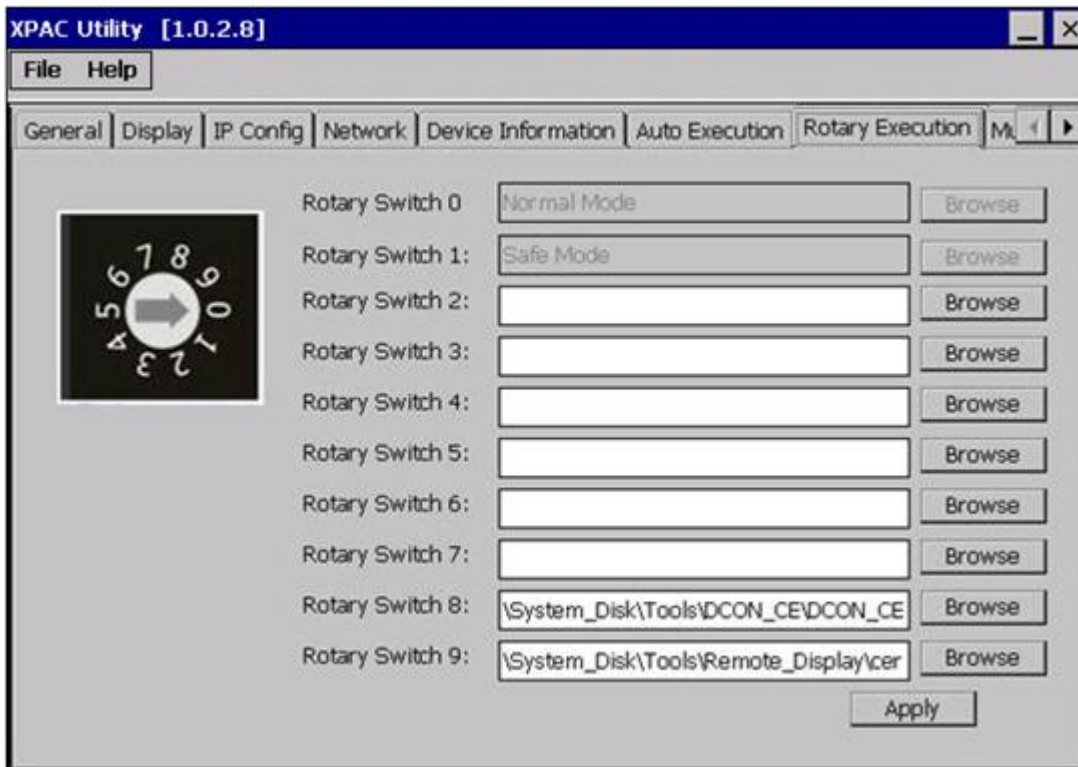

The tab used to	How to use
Run at Normal Mode	Rotary Switch to 0 and reboot XP-8000-Atom-CE6, and then it is in the Normal Mode.
Run at Safe Mode	Rotary Switch to 1 and reboot XP-8000-Atom-CE6, and then it is in the Safe Mode. (In Safe Mode, XP-8000-Atom-CE6 clears the data saved in the registry, starts as factory default, and no applications run at startup.)
Run at Normal Mode but execute DCON_CE_V600.exe	Rotary Switch to 8 and reboot XP-8000-Atom-CE6, and then it is in the Normal Mode but executes DCON_CE_V600.exe. This makes users can use DCON Utility on PC side to configure I/O

	modules without a monitor.
Run at Normal Mode but execute cerdisp.exe	Rotary Switch to 9 and reboot XP-8000-Atom-CE6, and then it is in the Normal Mode but executes cerdisp.exe. This makes users can use cerhost.exe on PC side to remote display Windows CE without a monitor.
Run at Normal Mode but execute user-specified program.	Rotary Switch to 2 ~ 7 and reboot XP-8000-Atom-CE6, and then it is in the Normal Mode but executes the program user specified in the field of "Rotary Switch 2 ~ 7".

## ► Multi-IO Modules tab

The Multi-IO Modules tab provides function to check the driver of multi-IO modules, such as 8114, 8144, 8142, and 8112.

Each serial port of the Multi-IO modules has different numbers for use. The 8144 has four serial ports that are numbered MSB1~3.

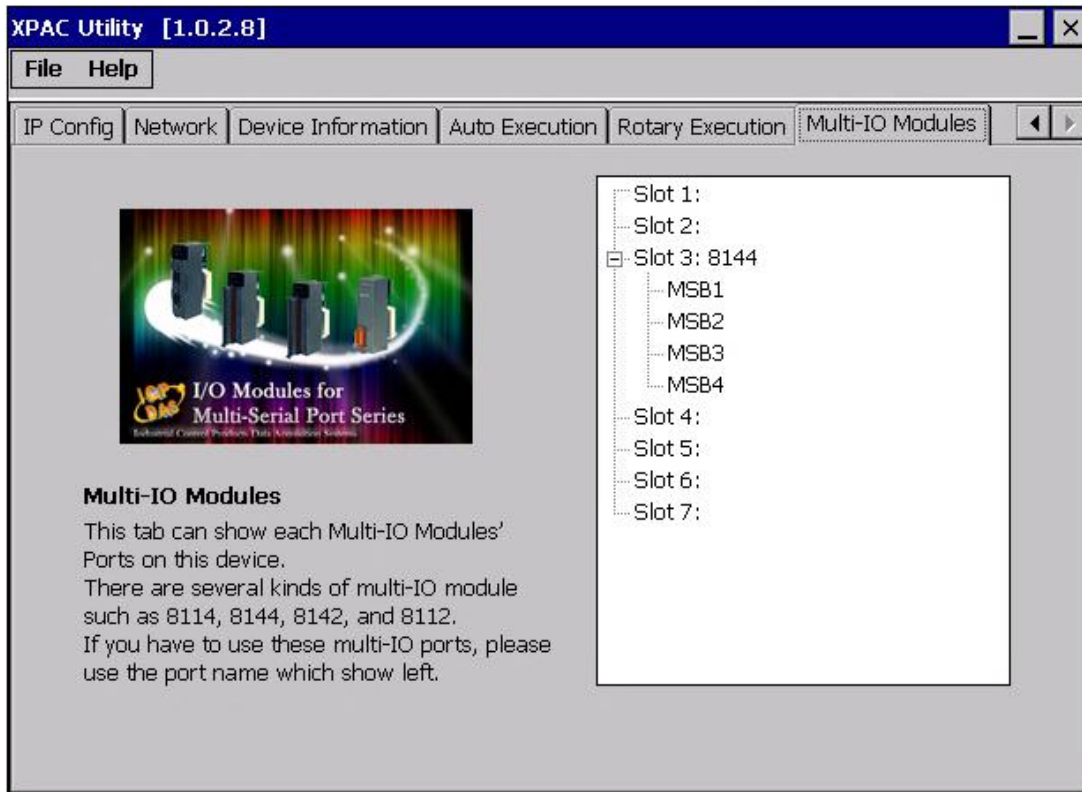

For more information about expansion RS-232/RS-422/RS-485 communication module that are compatible with the XP-8000-Atom-CE6, please refer to

[http://www.icpdas.com/products/Remote\\_IO/i-8ke/selection\\_rs232\\_i8k.htm](http://www.icpdas.com/products/Remote_IO/i-8ke/selection_rs232_i8k.htm)

## 3.2. Tools and Tasks on PC

### 3.2.1. DCON\_UTILITY

The DCON Utility is a client utility that runs on PC, and communicates with XP-8000-Atom-CE6 via DCON protocol. The DCON Utility allows users to remotely connect to I-7K and I-87K series I/O modules for management through the COM port and Ethernet port.

This tool is composed of two parts, a client and a server. The server is a program named DCON\_CE\_Vxxx running on XP-8000-Atom-CE6. The client is a PC-based program named DCON Utility running on the PC.

For more information on how to use DCON Utility to configure I/O modules, please refer to section 2.7. Using DCON Utility to Configure I/O Module.

## 3.2.2. Remote\_Display

The "Remote Display" is a Windows CE functionality that allows XP-8000-Atom-CE6 to be controlled and monitored from a remote location. This tool is composed of two parts, a client and a server. The server is a program named cerdisp.exe running on XP-8000-Atom-CE6. The client is a PC-based program named cerhost.exe running on the PC.

For more information on how to use remote display to control the XP-8000-Atom-CE6 remotely, please refer to section 2.6. Using Remote Display to Control the XP-8000-Atom-CE6 Remotely.





## 4. Your First XP-8000-Atom-CE6 Program

This chapter provides a guided tour that describes the steps needed to set-up a development environment, download, install, configure for user programming with the XP-8000-Atom-CE6.



Before writing your first program, ensure that you have the necessary development tool and the corresponding XP-8000-Atom-CE6 SDKs are installed on your system.

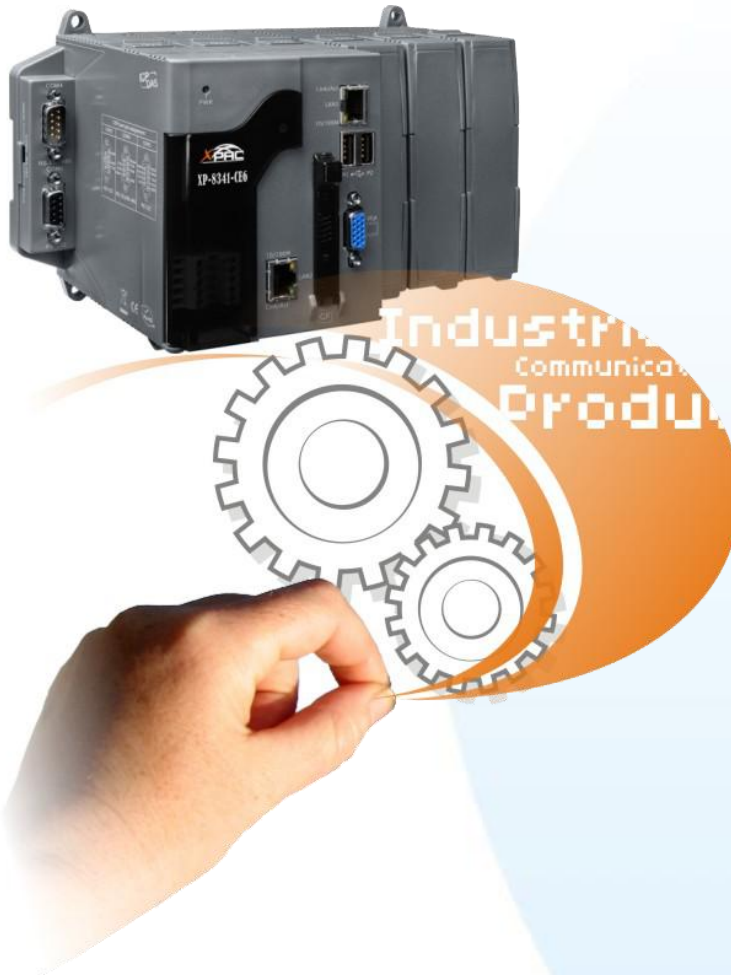

## 4.1. Selecting a Development Tools

XP-8000-Atom-CE6 is a Windows CE-based unit. Windows CE is a mature embedded operating system which supports rapid development. Two standard development tools are list as follows which are highly integrated, with comprehensive support for developing applications of Windows CE-based XP-8000-Atom-CE6.

### ➤ Visual Studio

---



#### Visual Studio

XP-8000-Atom-CE6 has .NET Compact Framework 3.5 installed. Visual Studio takes full advantage of the .NET Compact Framework, which uses public Internet standards to enable integration with new and existing applications running on any platform. Supported languages include Visual C#, Visual C++ and Visual Basic .NET.

## 4.2. Installing the XP-8000-Atom-CE6 SDKs

The XPAC SDK is a Software Development Kit (SDK) that contains C header files, C libraries and documents.

### Step 1 Get the XP-8000-Atom-CE6 platform SDK

The XP-8000-Atom-CE6 platform SDK can be installed from the CD that was provided with the package or by downloading the latest version from ICP DAS web site.

#### Platform SDK:

CD:\XPAC-ATOM-CE6\SDK\PlatformSDK\

<ftp://ftp.icpdas.com/pub/cd/xpac-atom-ce6/sdk/platformsdk/>

### Step 2 Install the XP-8000-Atom-CE6 platform SDK

- i. Double-Click XP-8000-Atom-CE6 platform SDK installation file
- ii. On the first page of the wizard, click Next button



- iii. On the next page of the wizard, click Accept option, and then click Next button

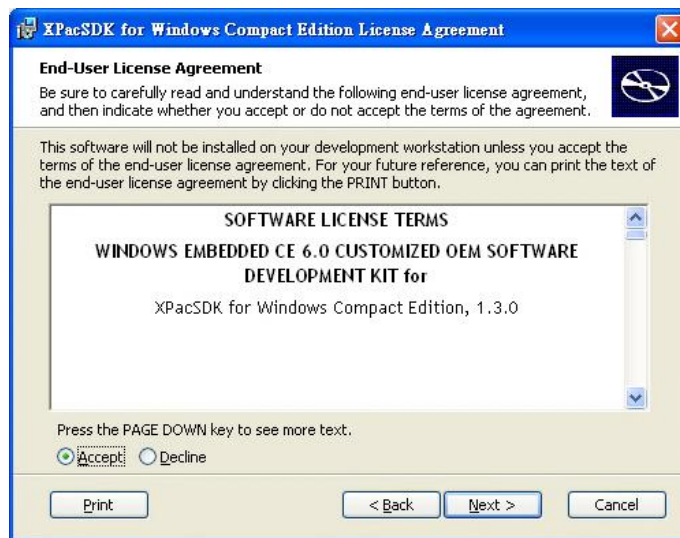

- iv. On the next page of the wizard, fill the User Name and Organization fields, and then click Next button

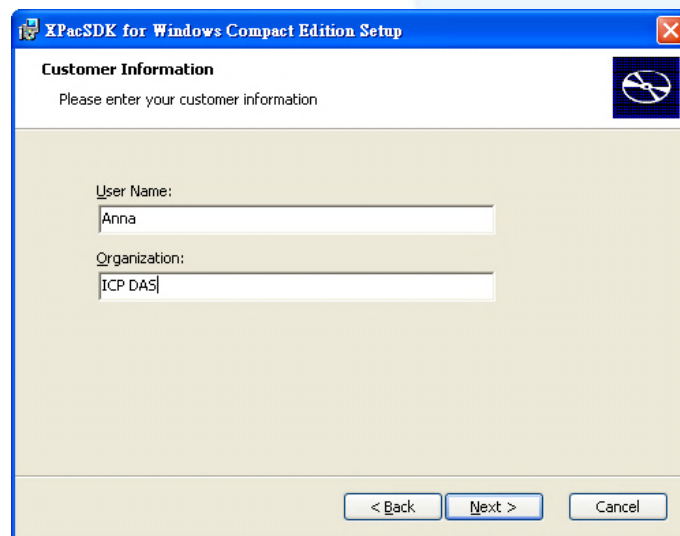

## v. Choose setup type

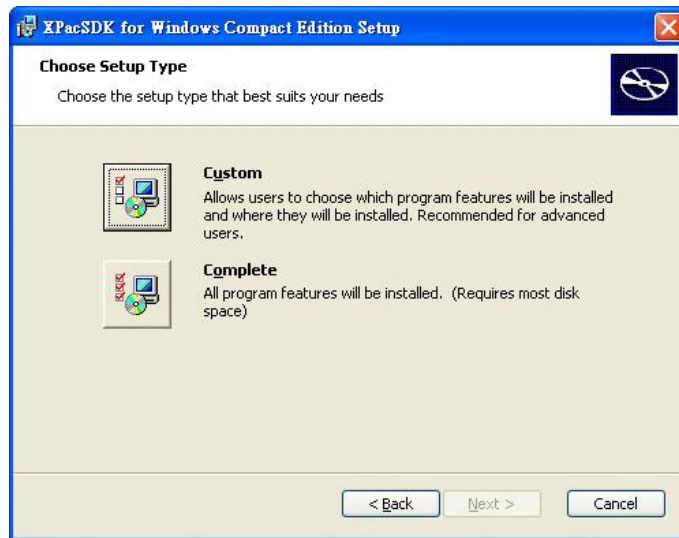

## Tips & Warnings



If your PC only has installed Microsoft Visual Studio 2008 without installing Microsoft Visual Studio 2005, in this step, please choose custom type, and then make the Documentation unavailable.

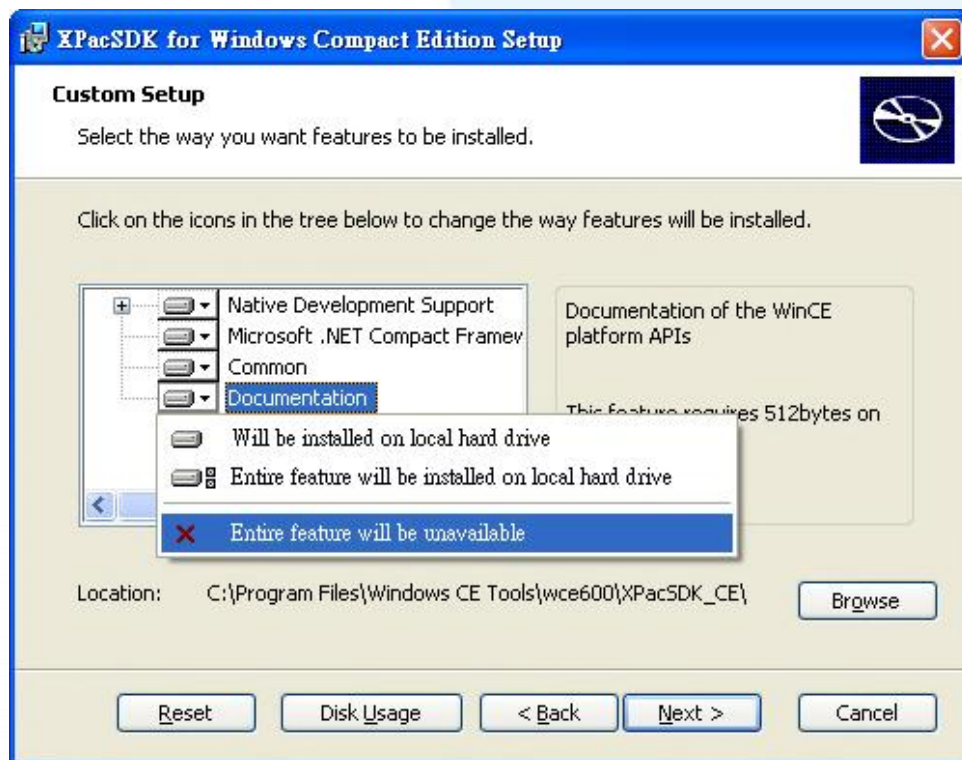

If you fail this step, you might encounter an error message as below.  
Please reinstall again and be sure to follow this step.

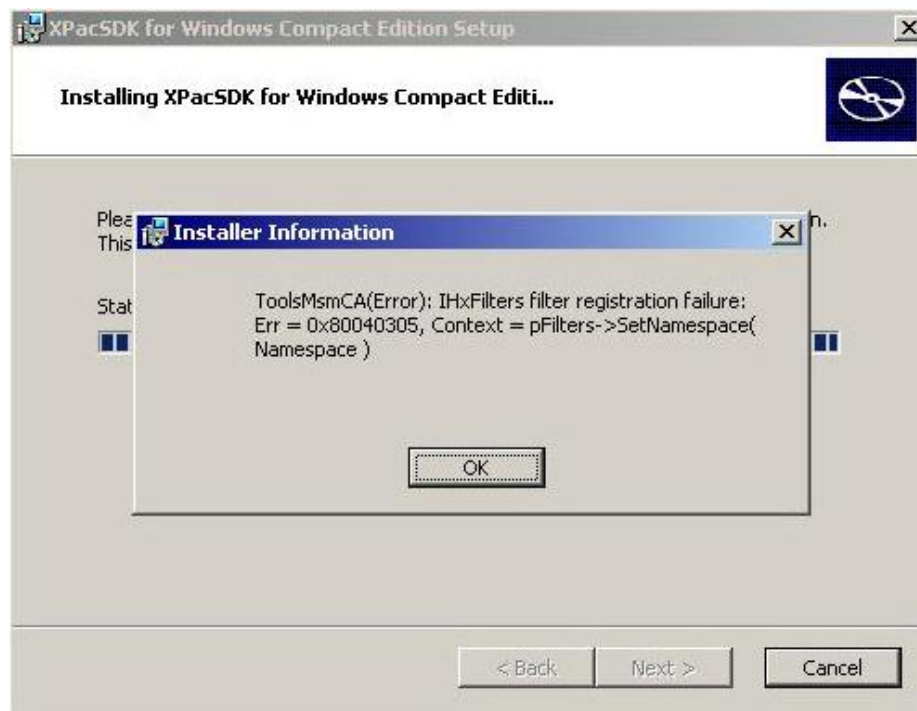

### Step 3 Follow the prompts until the installation is complete

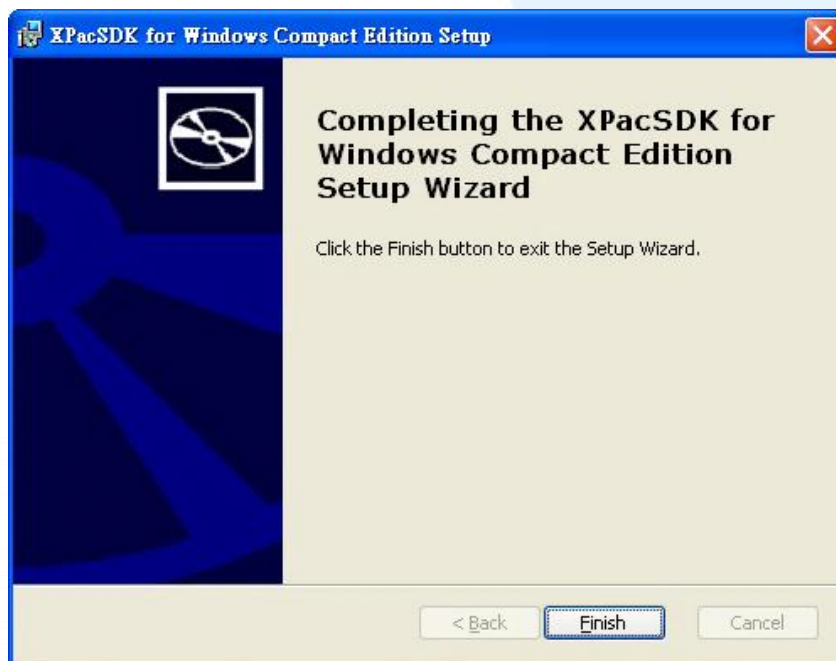

#### **Step 4 Get the XP-8000-Atom-CE6 SDK and copy it to the PC**

The XP-8000-Atom-CE6 SDK can be obtained from the CD or by downloading the latest version from ICP DAS web site. You can copy it to a location that you have specified.

CD:\XPAC-ATOM-CE6\SDK\XPACSDK\

<ftp://ftp.icpdas.com/pub/cd/xpac-atom-ce6/sdk/xpacsdk/>

## 4.3. Creating Your First XP-8000-Atom-CE6 Program

The best way to learn programming with XP-8000-Atom-CE6 is to actually create a XP-8000-Atom-CE6 program.

Here we will guide you through creating this simple program in both VB.net, C# and C++.



### **4.3.1. Your First XP-8000-Atom-CE6 Program with the VB.net**

Here we will demonstrate how to create a VB.net program running on XP-8000-Atom-CE6 with the VB.net development tool

1. Create a new project
2. Specify the path of the XPAC reference
3. Add the control to the form
4. Add the event handling for the control
5. Upload the application to XP-8000-Atom-CE6
6. Execute the application on XP-8000-Atom-CE6

In this tutorial, we will assume that you have installed XPAC platform SDK on PC and used the Visual Studio 2008 for application development.

### 4.3.1.1. Creating a New Project

The Visual VB.net project template is a composite control that you use in this example creates a new project with this user control.

#### Step 1 Start Visual Studio 2008



Visual Studio 2008

#### Step 2 On the File menu, point to New, and then click Project

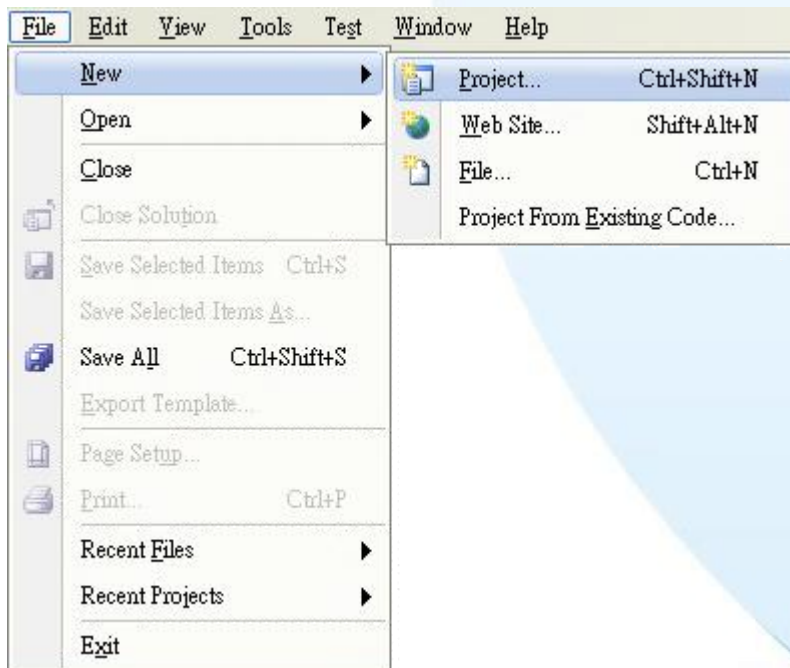

**Step 3** In the Project types pane, expand Visual Basic, and then click Smart Device

**Step 4** In the Templates pane, click Smart Device

**Step 5** Type a name in the Name field, and then click OK

Here we will enter the name “SDKInformation” and a different location for the project if you wish

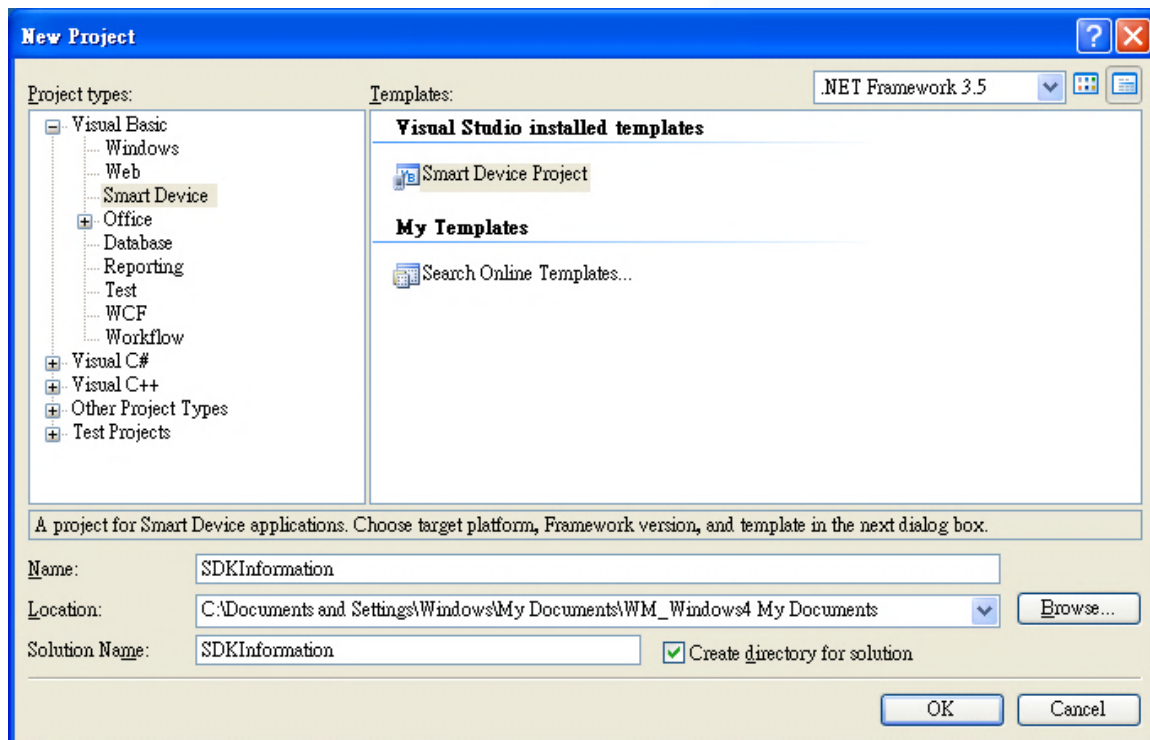

**Step 6** In the Target platform item, choose Windows CE

**Step 7** in the .NET Compact Framework version item, choose .NET Compact Framework Version 3.5

**Step 8** in the Templates pane, choose Device Application, and then click Next

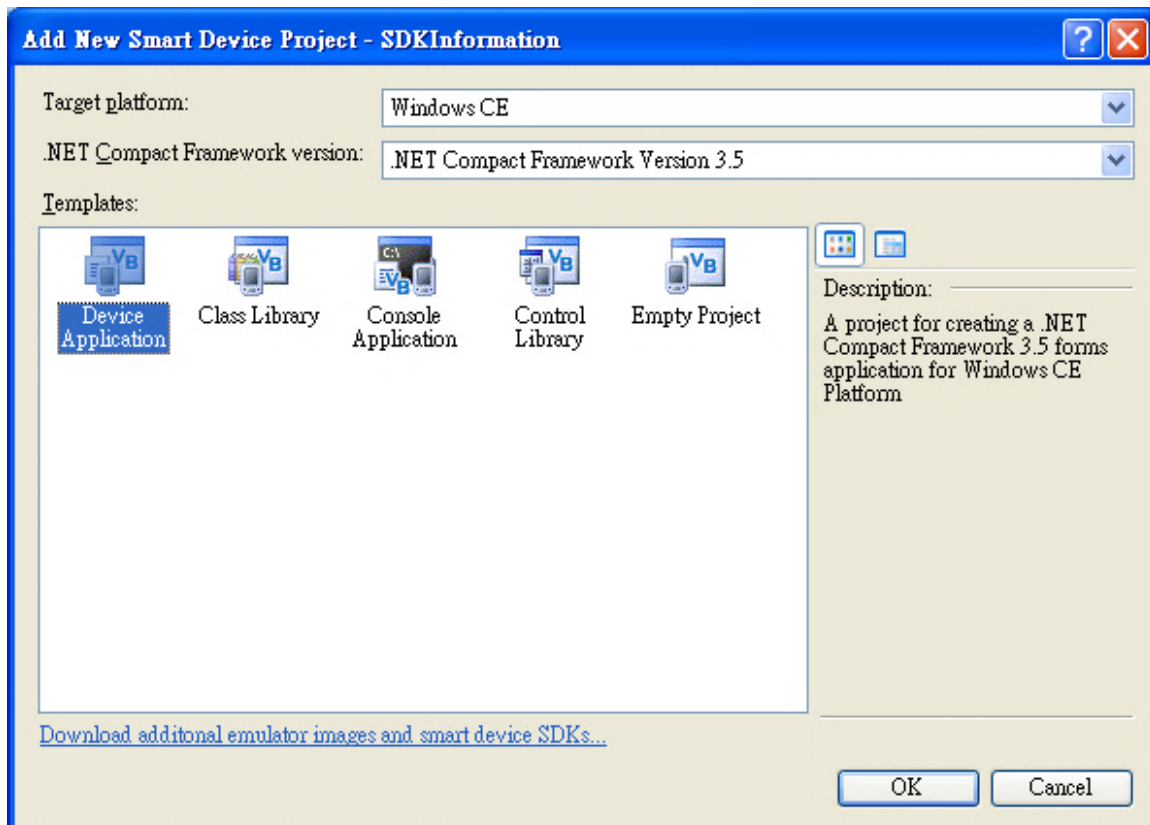

### 4.3.1.2. Specifying the Path of the XPAC Reference

The XPAC SDK provides a complete solution to integrate with XPAC and it's compatible with Visual C#, Visual Basic .net and C++. In order to use a component in your application, you must first add a reference to it.

#### Step 1 Get the XPacNET.dll and copy it to the project folder

The XPacNET.dll can be obtained from the link below that has been provided on the CD or by downloading the latest version from ICP DAS web site.

CD:\XPAC-ATOM-CE6\SDK\XPacNET\

<ftp://ftp.icpdas.com/pub/cd/xpac-atom-ce6/sdk/xpacnet/>



**Step 2** In Solution Explorer, right-click the References node, and then click Add Reference...

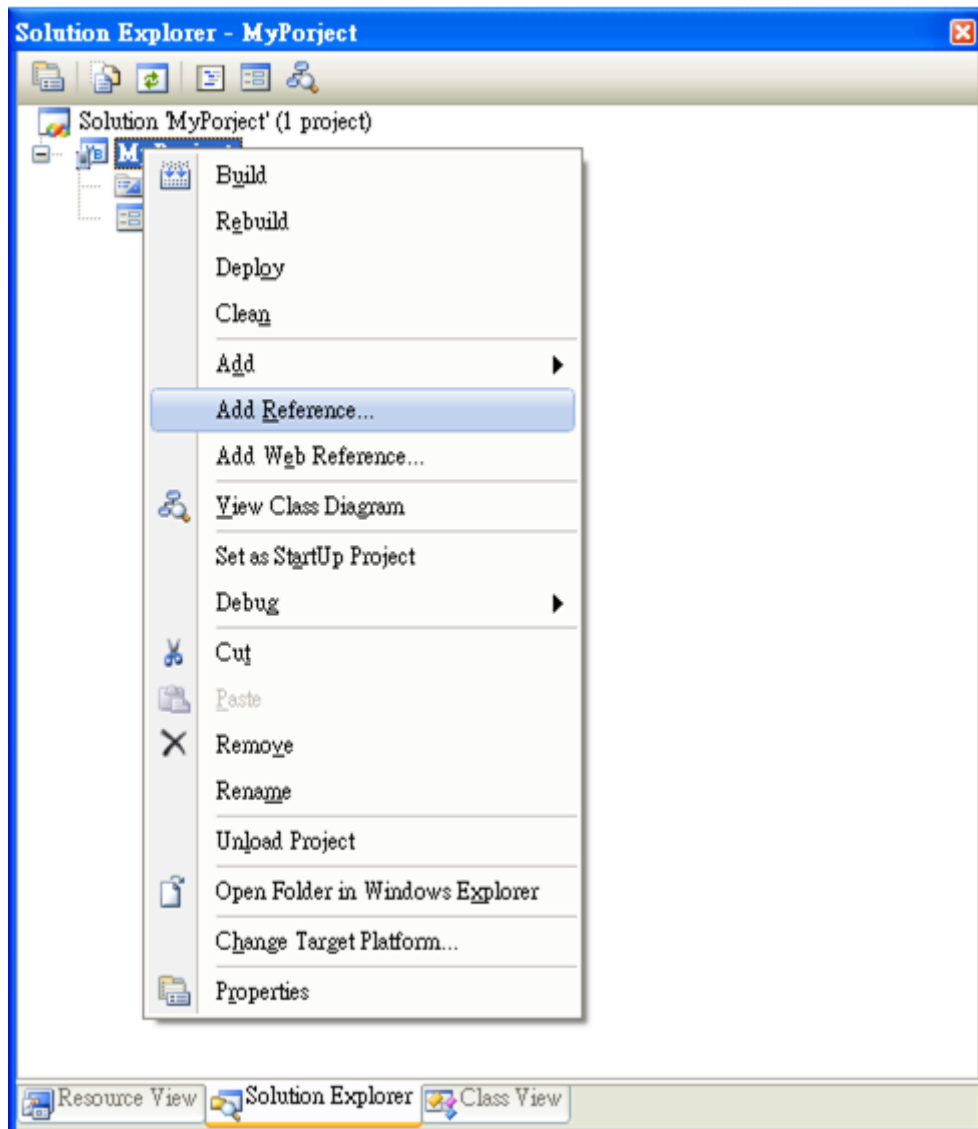

### Step 3 Select “Browse” tab and add the XPacNET.dll

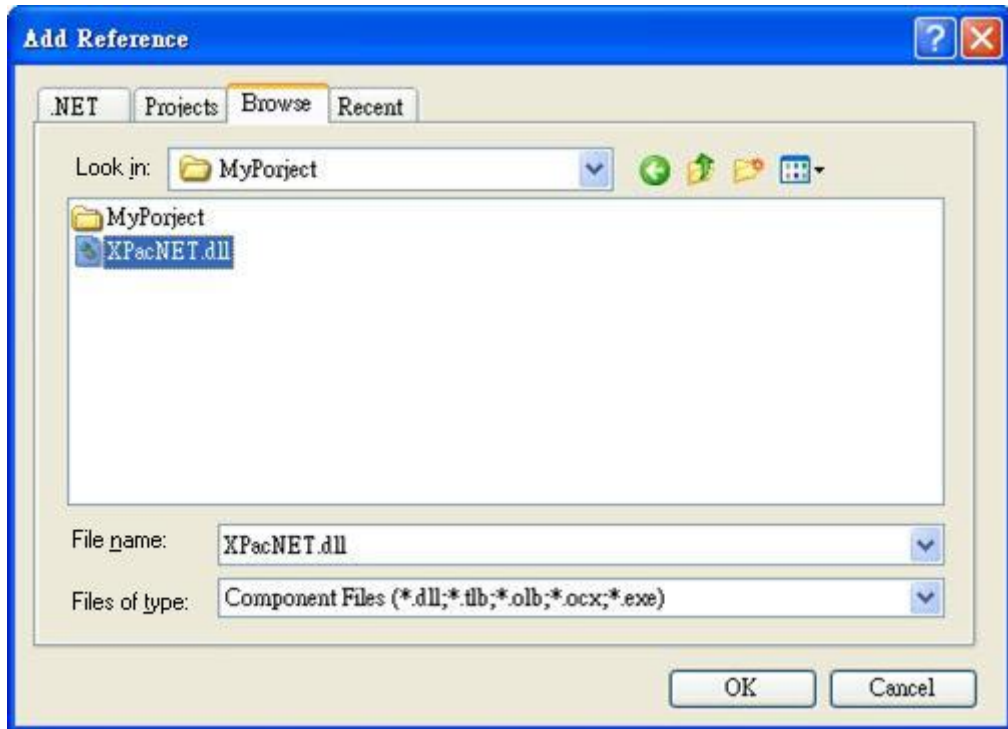

### 4.3.1.3. Adding the Control to the Form

You can drag various controls from the Toolbox onto the form. These controls are not really "live"; they are just images that are convenient to move around on the form into a precise location.

After you add a control to your form, you can use the Properties window to set its properties, such as background color and default text. The values that you specify in the Properties window are the initial values that will be assigned to that property when the control is created at run time.

#### Step 1 From the Toolbox, drag a Button control onto the form

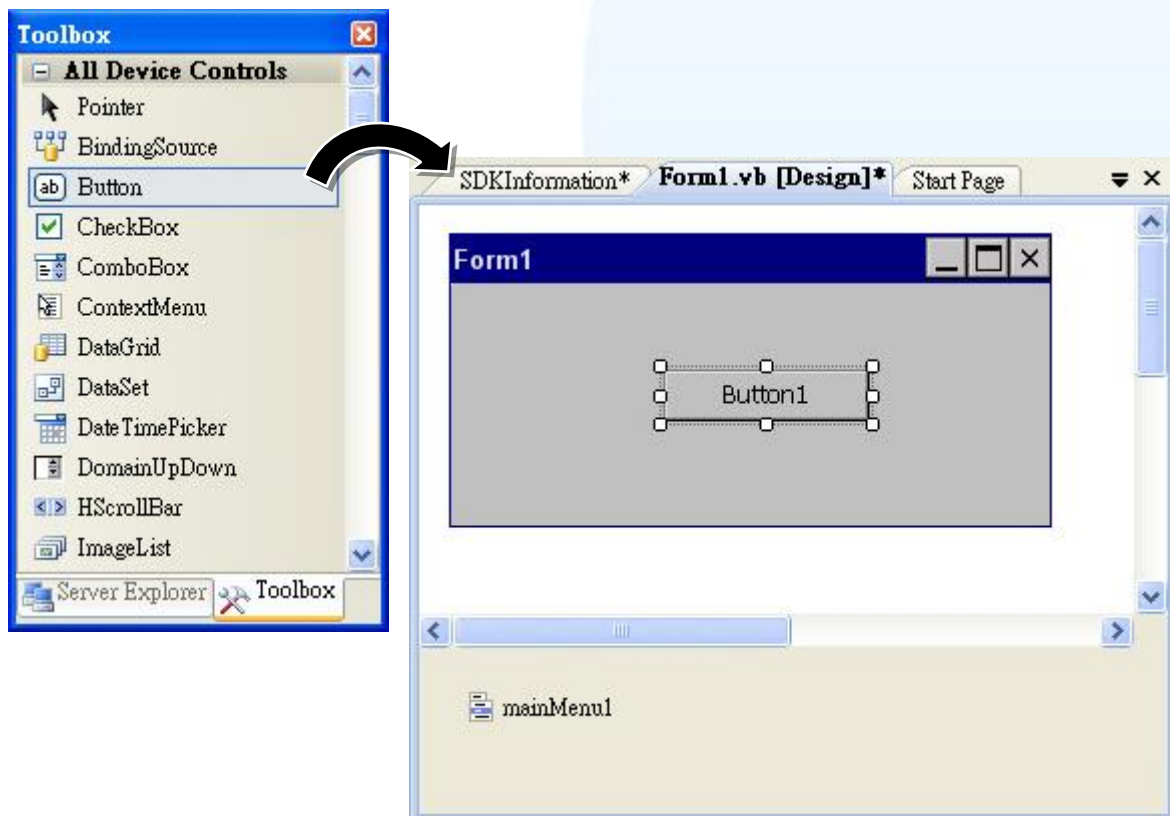



## Step 2 Right-click the Button control, and then click Properties

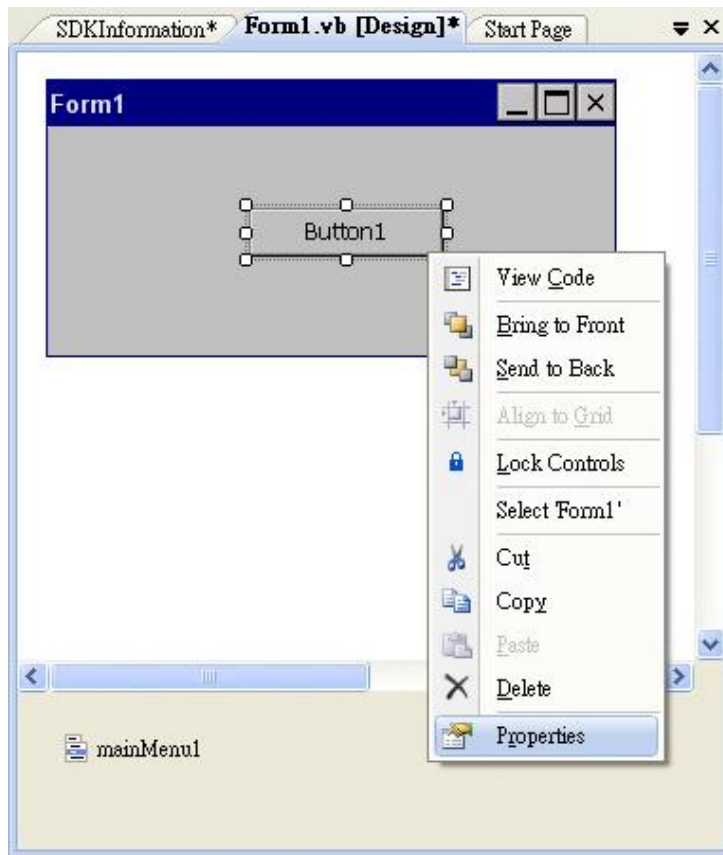

## Step 3 In the Properties window, type Check the SDK version, and press ENTER to set the Text property

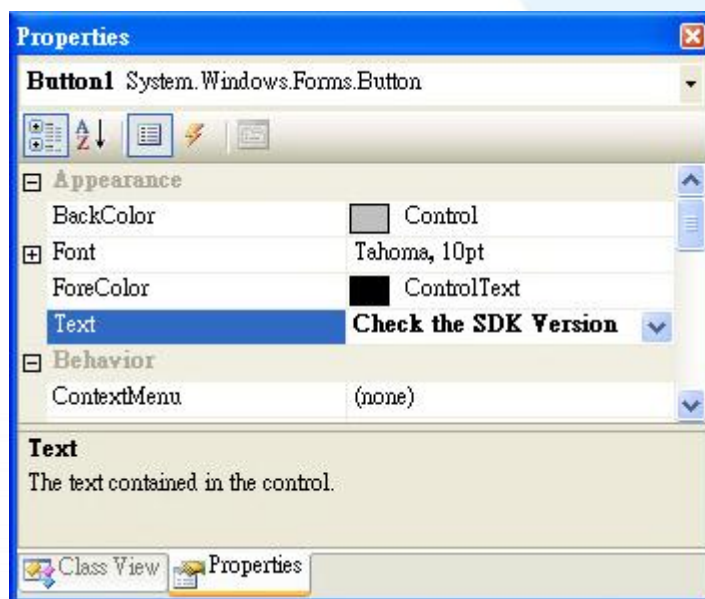

### 4.3.1.4. Adding the Event Handling to the Control

You have finished the design stage of your application and are at the point when you can start adding some code to provide the program's functionality.

#### Step 1 Double-click the button on the form

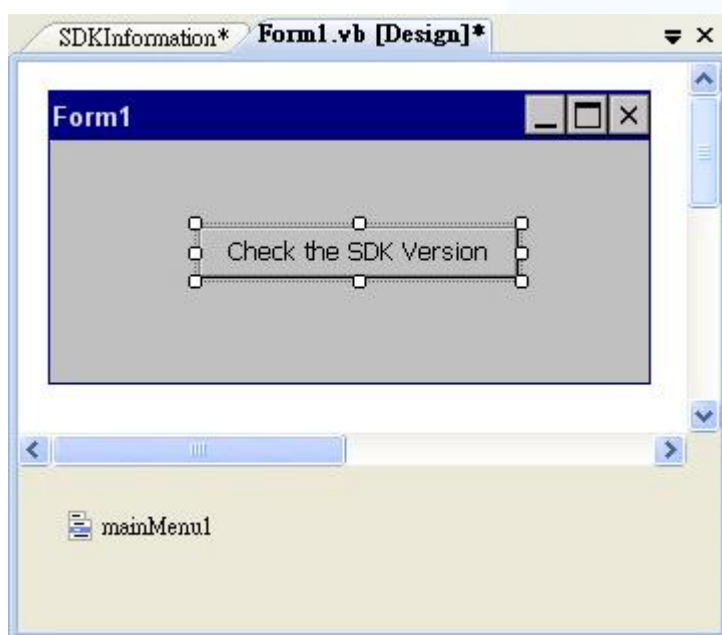

## Step 2 Inserting the following code

```
MessageBox.Show(XPacNET.XPac.pac_GetXPacSDKVersion())
```

```
Public Class Form1
    Private Sub Button1_Click(ByVal sender As System.Object, ByVal e As System.EventArgs) Handles Button1.Click
        MessageBox.Show(XPacNET.XPac.pac_GetXPacSDKVersion())
    End Sub
End Class
```

### Tips & Warnings

---



The “XPacNET” of “unsing XPacNET” is case- sensitive.

---

### 4.3.1.5. Uploading the Application to XP-8000-Atom-CE6

XP-8000-Atom-CE6 provide FTP server service, you can upload files to XP-8000-Atom-CE6 or download files from a public FTP server.

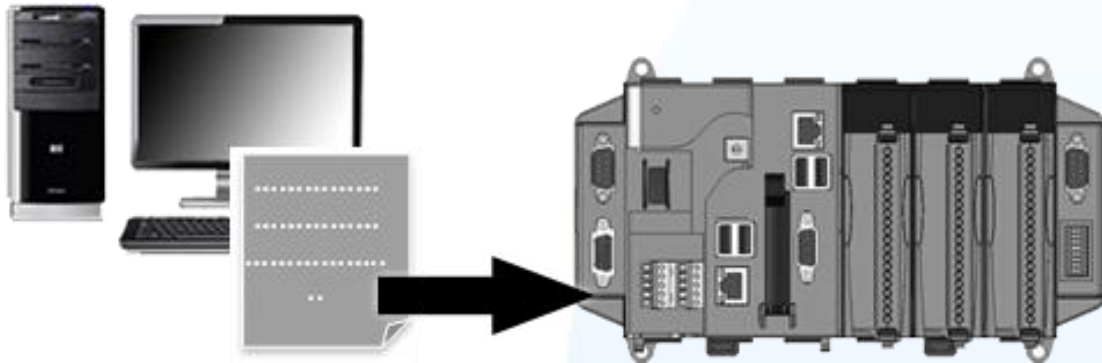

#### Step 1 On the Build menu, click Build SDKInformation

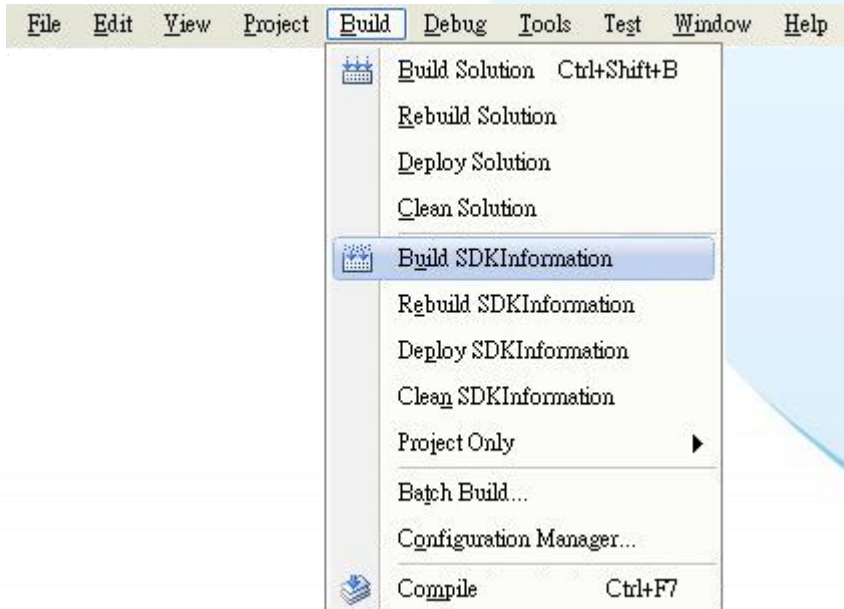

**Step 2** Open the browser and type the IP address of XP-8000-Atom-CE6

**Step 3** Upload the SDKInformation.exe application and the corresponding XPacSDK\_CE.dll and XPacNET.dll files to the XPAC

### Tips & Warnings

---



For applications programming in C# and VB.net with .net compact framework, when executing these application on the XP-8000-Atom-CE6, the corresponding XPacSDK\_CE.dll and XPacNET.dll must be in the same directory as the .exe file.

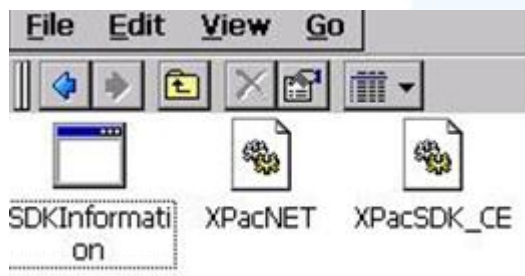

### **4.3.1.6. Executing the Application on XP-8000-Atom-CE6**

After uploading the application to XP-8000-Atom-CE6, you can just double-click it on XP-8000-Atom-CE6 to execute it.

### **4.3.2. Your First XP-8000-Atom-CE6 Program with the Visual C#**

Here we will demonstrate how to create a Visual C# program running on XP-8000-Atom-CE6 with the Visual C# development tool

1. Create a new project
2. Specify the path of the XPAC reference
3. Add the control to the form
4. Add the event handling for the control
5. Upload the application to XP-8000-Atom-CE6
6. Execute the application on XP-8000-Atom-CE6

In this tutorial, we will assume that you have installed XPAC platform SDK on PC and used the Visual Studio 2008 for application development.

## 4.3.2.1. Creating a New Project

The Visual C# project template is a composite control that you use in this example creates a new project with this user control.

### Step 1 Start Visual Studio 2008



### Step 2 On the File menu, point to New, and then click Project

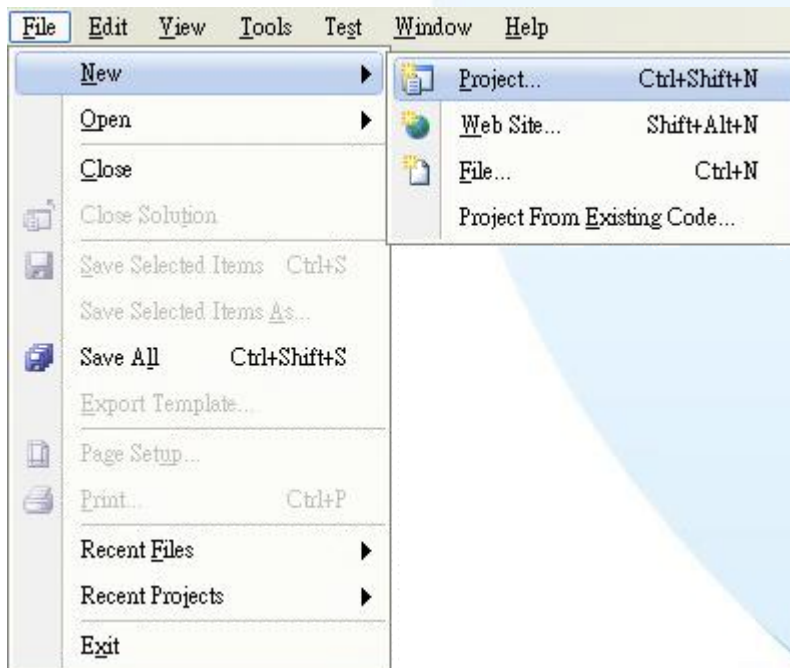



**Step 3** In the Project types pane, expand Visual C#, and then click Smart Device

**Step 4** In the Templates pane, click Smart Device

**Step 5** Type a name in the Name field, and then click OK

Here we will enter the name “SDKInformation” and a different location for the project if you wish

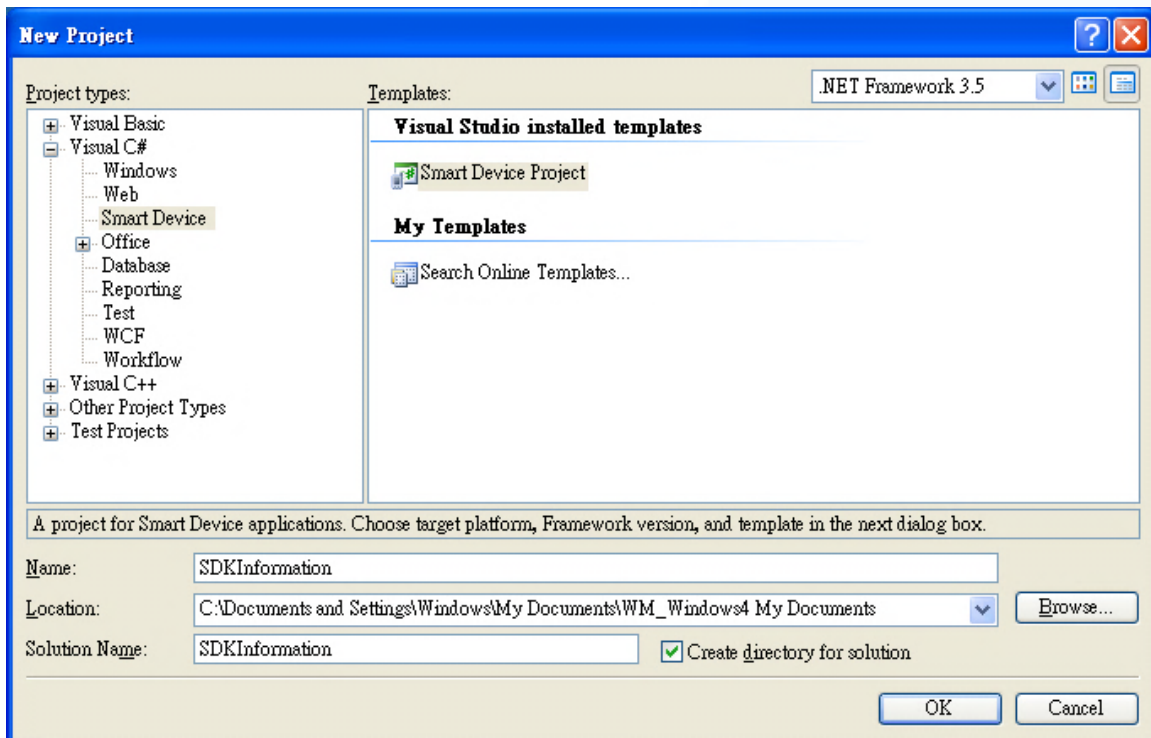

**Step 6** In the Target platform item, choose Windows CE

**Step 7** in the .NET Compact Framework version item, choose .NET Compact Framework Version 3.5

**Step 8** in the Templates pane, choose Device Application, and then click Next

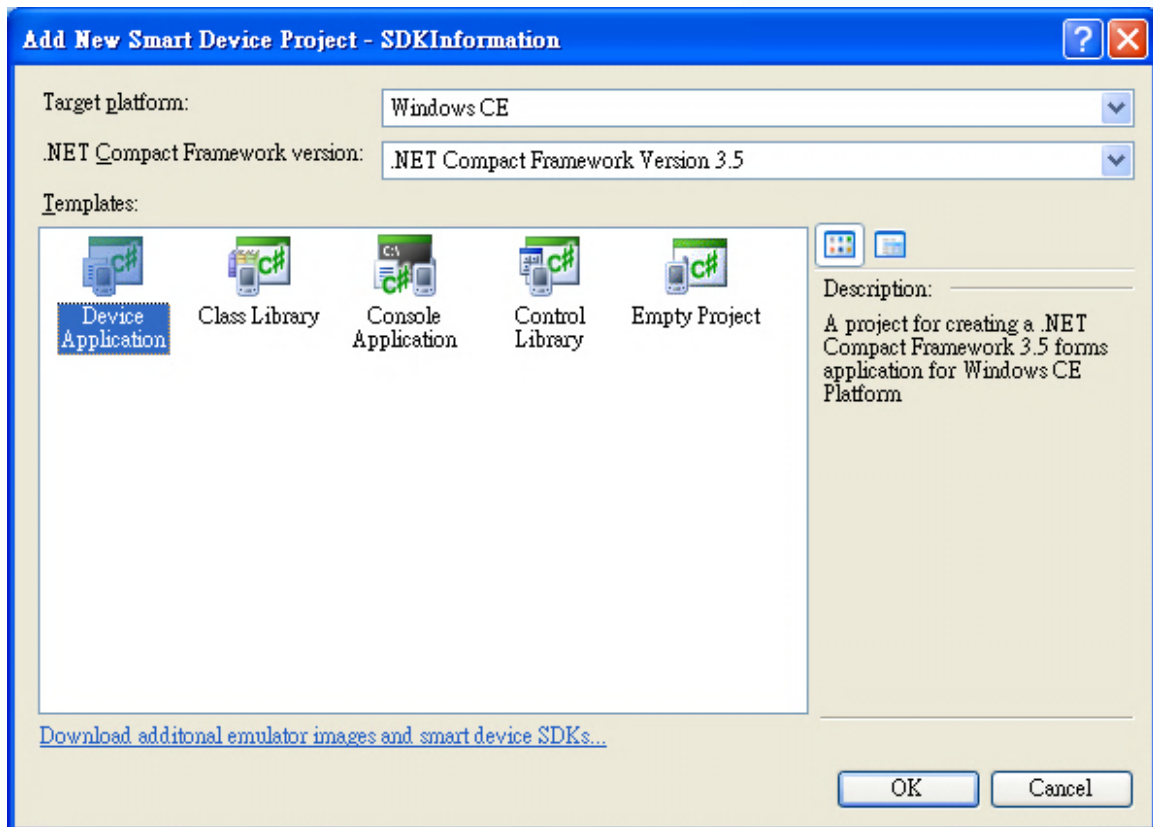

## 4.3.2.2. Specifying the Path of the XPAC Reference

The XPAC SDKs provides a complete solution to integrate with XPAC and it's compatible with Visual C#, Visual Basic .net and C++. In order to use a component in your application, you must first add a reference to it.

### Step 1 Get the XPacNET.dll and copy it to the project folder

The XPacNET.dll can be obtained from the link below that has been provided on the CD or by downloading the latest version from ICP DAS web site.

CD:\XPAC-ATOM-CE6\SDK\XPacNET\

<ftp://ftp.icpdas.com/pub/cd/xpac-atom-ce6/sdk/xpacnet/>



**Step 2** In Solution Explorer, right-click the References node and then click Add Reference...

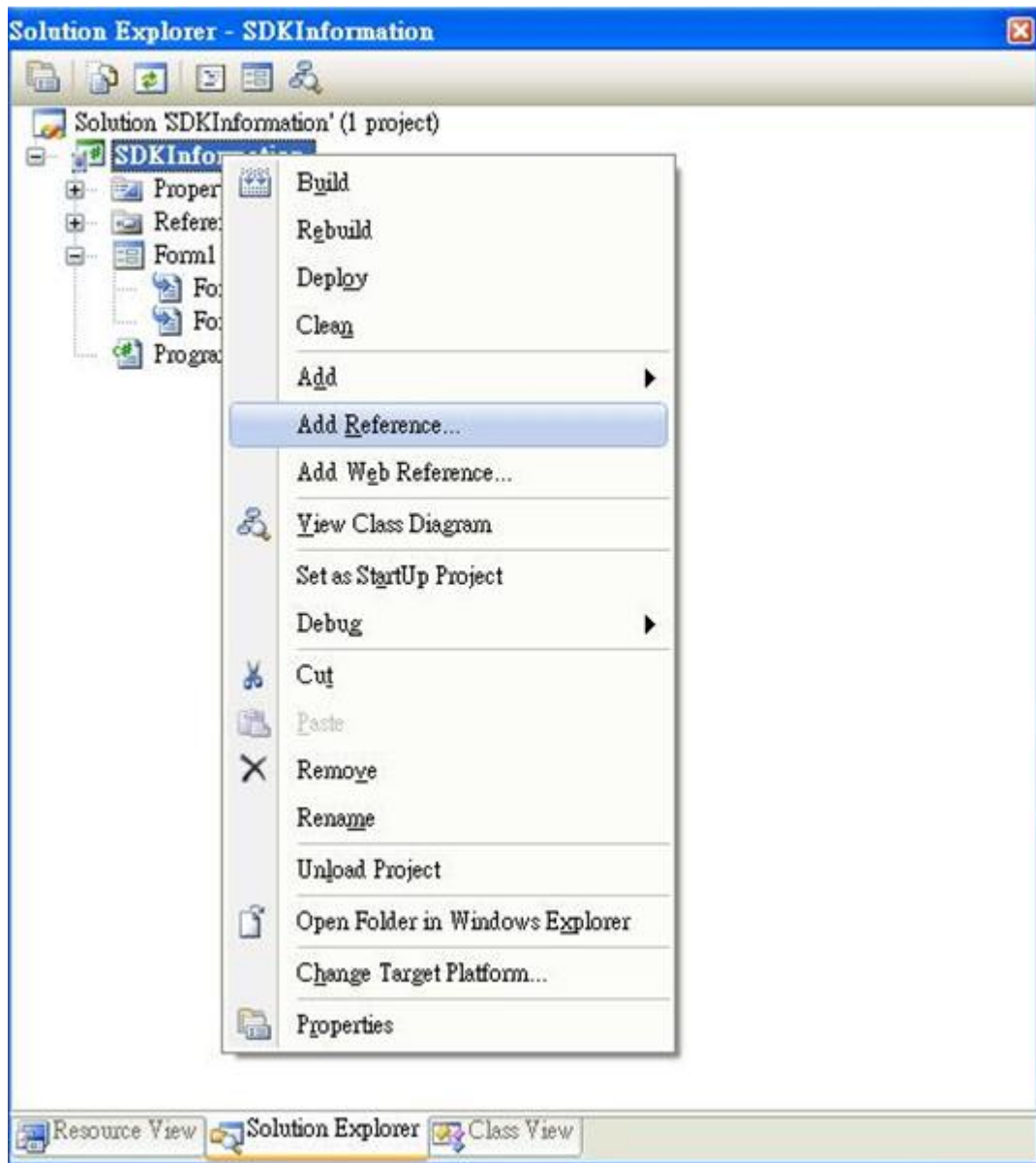

### Step 3 Select “Browse” tab and add the XPacNET.dll

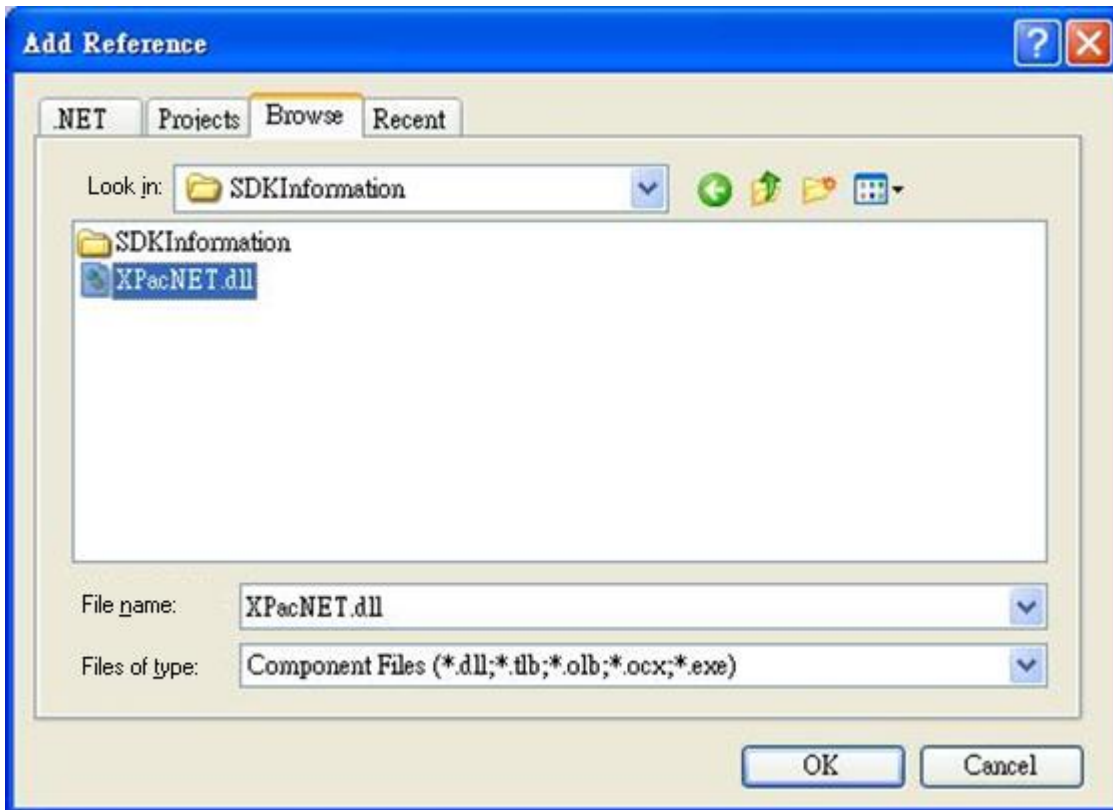

### 4.3.2.3. Adding the Control to the Form

You can drag various controls from the Toolbox onto the form. These controls are not really "live"; they are just images that are convenient to move around on the form into a precise location.

After you add a control to your form, you can use the Properties window to set its properties, such as background color and default text. The values that you specify in the Properties window are the initial values that will be assigned to that property when the control is created at run time.

#### Step 1 From the Toolbox, drag a Button control onto the form

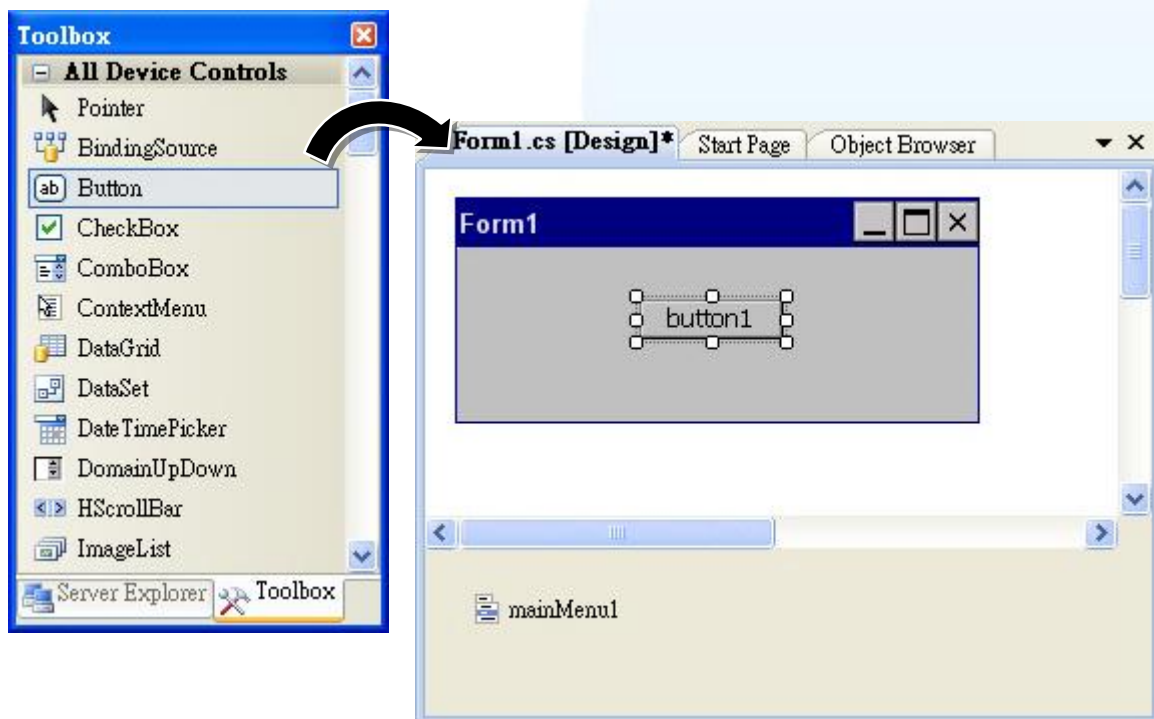

## Step 2 Right-click the Button control, and then click Properties

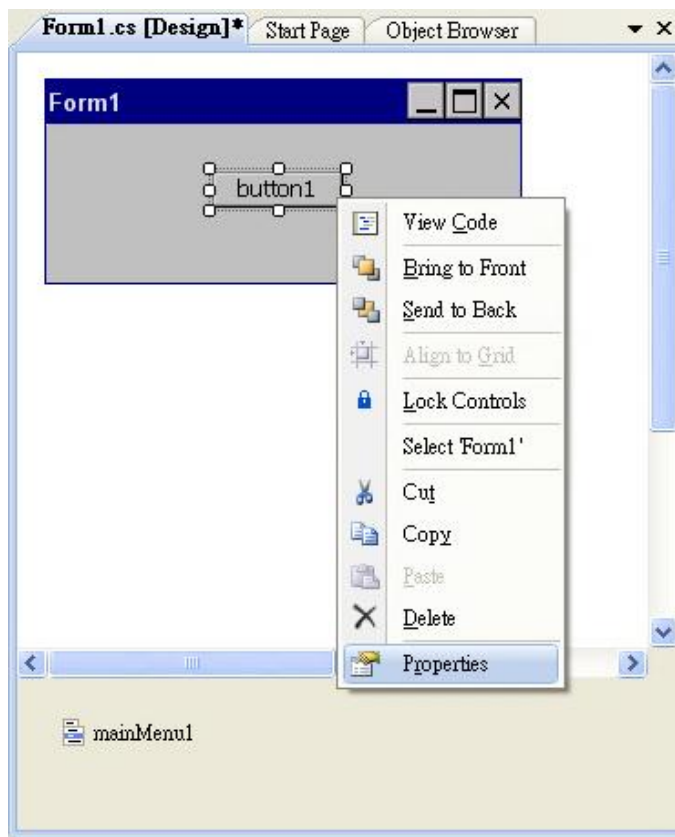

## Step 3 In the Properties window, type Check the SDK version, and press ENTER to set the Text property

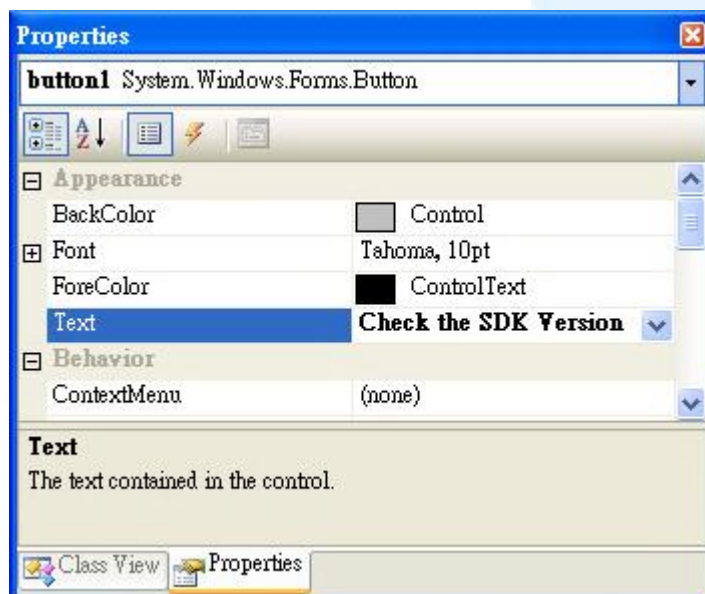

### 4.3.2.4. Adding the Event Handling to the Control

You have finished the design stage of your application and are at the point when you can start adding some code to provide the program's functionality.

#### Step 1 Double-click the button on the form

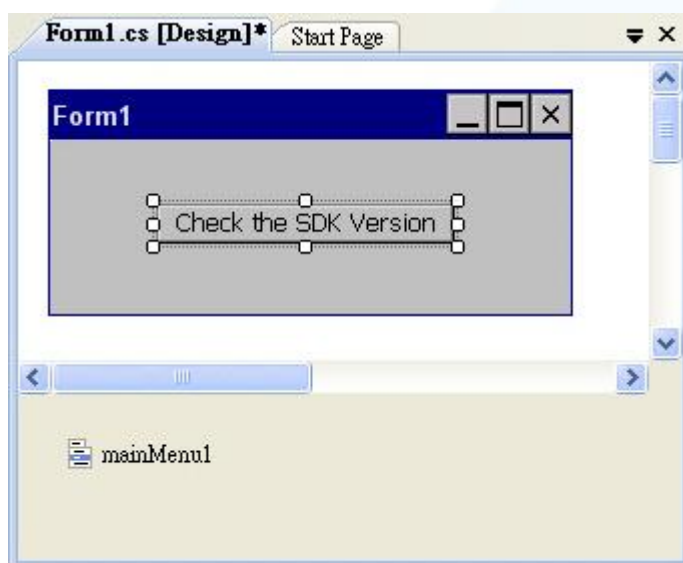



## Step 2 Inserting the following code

```
MessageBox.Show(XPacNET.XPac.pac_GetXPacSDKVersion());
```

```
namespace SDKInformation
{
    public partial class Form1 : Form
    {
        public Form1()
        {
            InitializeComponent();
        }

        private void button1_Click(object sender, EventArgs e)
        {
            MessageBox.Show(XPacNET.XPac.pac_GetXPacSDKVersion());
        }
    }
}
```

### 4.3.2.5. Uploading the Application to XP-8000-Atom-CE6

XP-8000-Atom-CE6 provide FTP server service, you can upload files to XP-8000-Atom-CE6 or download files from a public FTP server.

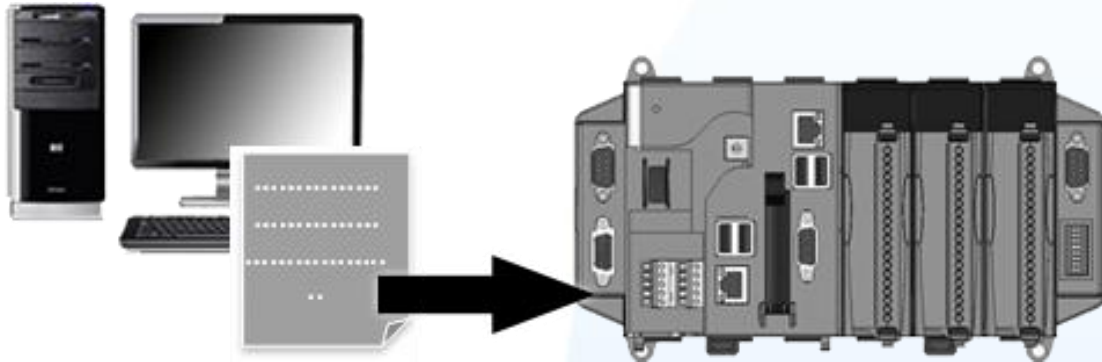

#### Step 1 On the Build menu, click Build SDKInformation

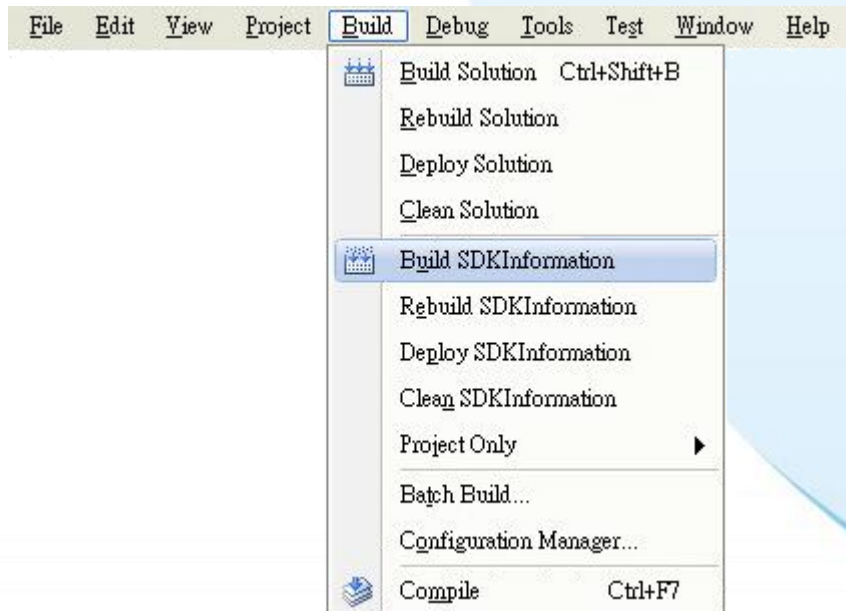

**Step 2** Open the browser and type the IP address of XP-8000-Atom-CE6

**Step 3** Upload the SDKInformation.exe application and the corresponding XPacSDK\_CE.dll and XPacNET.dll files to the XPAC

### Tips & Warnings

---



For applications programming in C# and VB.net with .net compact framework, when executing these application on the XP-8000-Atom-CE6, the corresponding XPacSDK\_CE.dll and XPacNET.dll must be in the same directory as the .exe file.

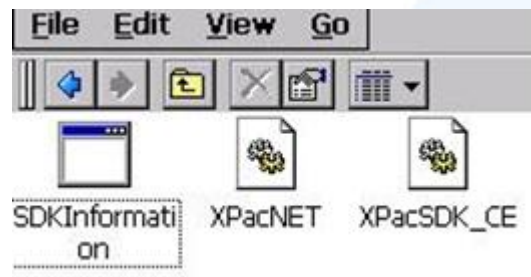

### **4.3.2.6. Executing the Application on XP-8000-Atom-CE6**

After uploading the application to XP-8000-Atom-CE6, you can just double-click it on XP-8000-Atom-CE6 to execute it.

### **4.3.3. Your First XP-8000-Atom-CE6 Program with the Visual C++**

Here we will demonstrate how to create a C++ program running on XP-8000-Atom-CE6 with the Visual C++ development tool

1. Create a new project
2. Configure the platform
3. Specify the path of the XPAC reference
4. Add the control to the form
5. Add the event handling for the control
6. Upload the application to XP-8000-Atom-CE6
7. Execute the application on XP-8000-Atom-CE6

In this tutorial, we will assume that you have installed XPAC platform SDK on PC and used the Visual Studio 2008 for application development.

### 4.3.3.1. Creating a New Project

The Visual C++ project template is a composite control that you use in this example creates a new project with this user control.

#### Step 1 Start Visual Studio 2008



Visual Studio 2008

#### Step 2 On the File menu, point to New, and then click Project

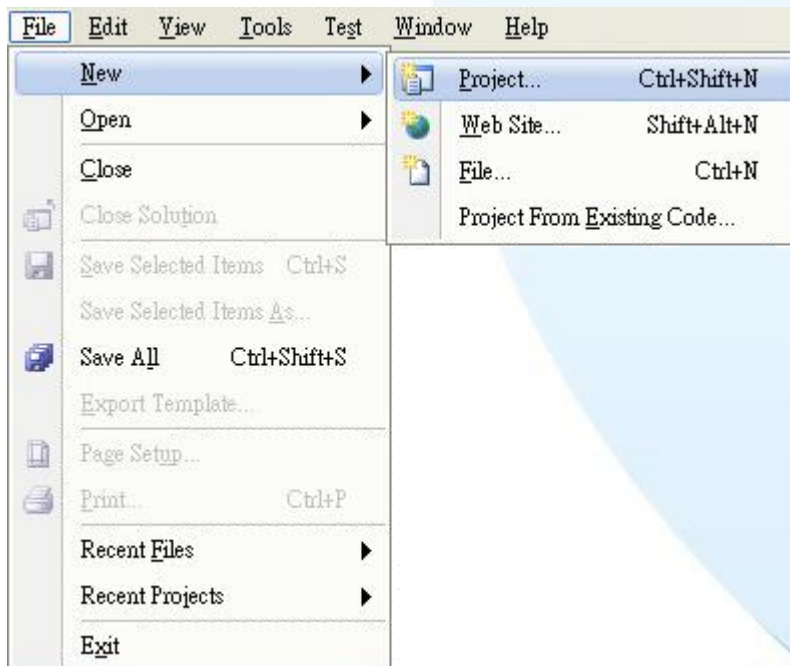

**Step 3** In the Project types pane, expand Visual C++, and then click Smart Device

**Step 4** In the Templates pane, click MFC Smart Device Application

**Step 5** Type a name in the Name field, and then click OK

Here we will enter the name “SDKInformation” and a different location for the project if you wish

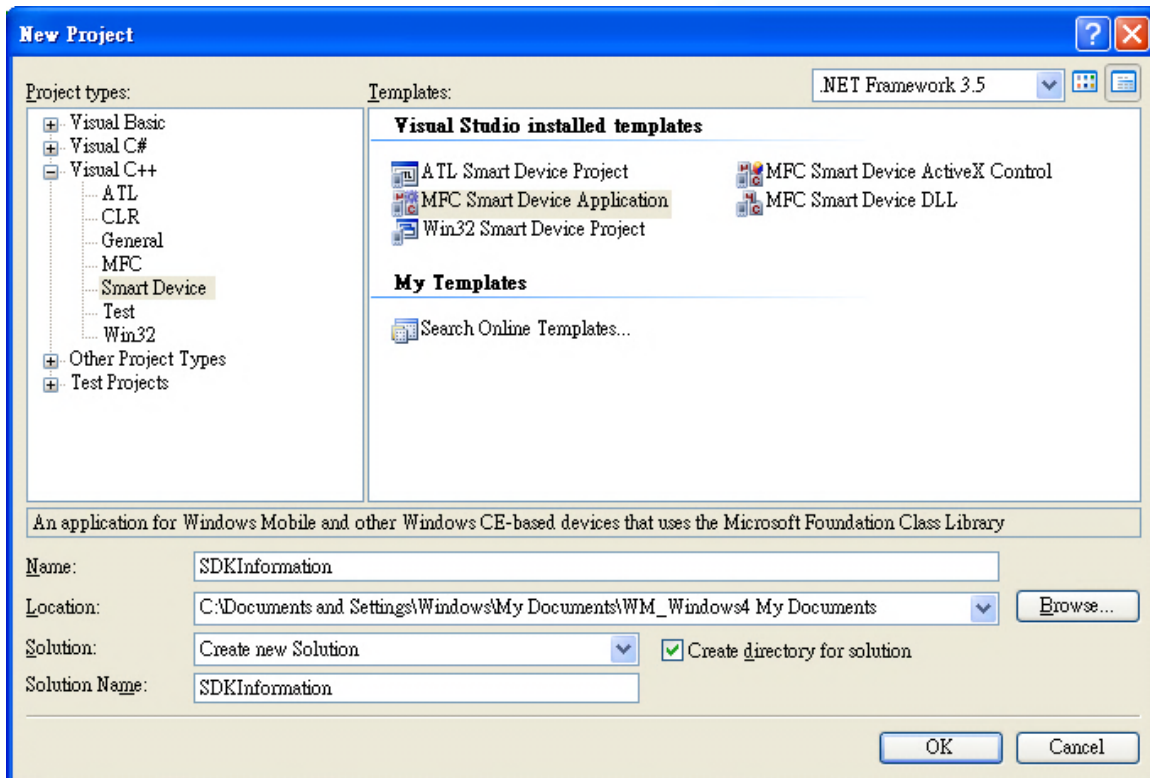

## Step 6 On the first page of the wizard, click Next

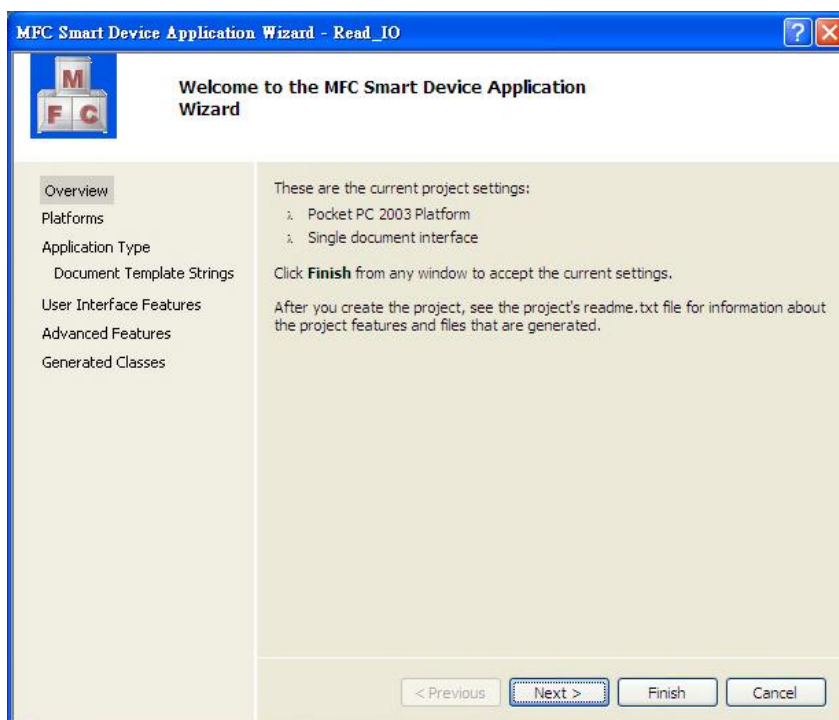

## Step 7 On the next page of the wizard, select XPacSDK\_CE to be added to the project, and then click Next

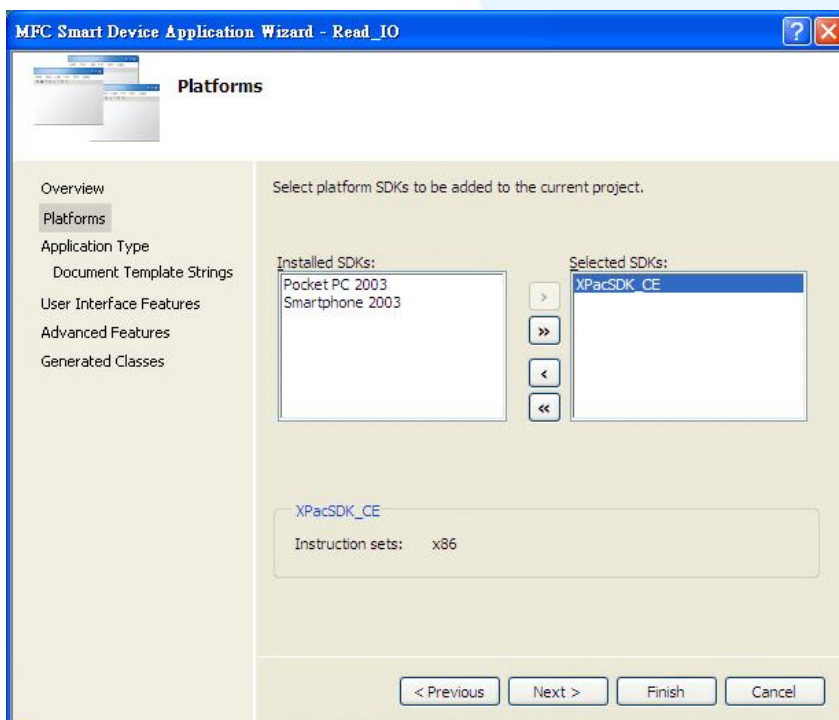



**Step 8** On the next page of the wizard, select Dialog based, and then click next

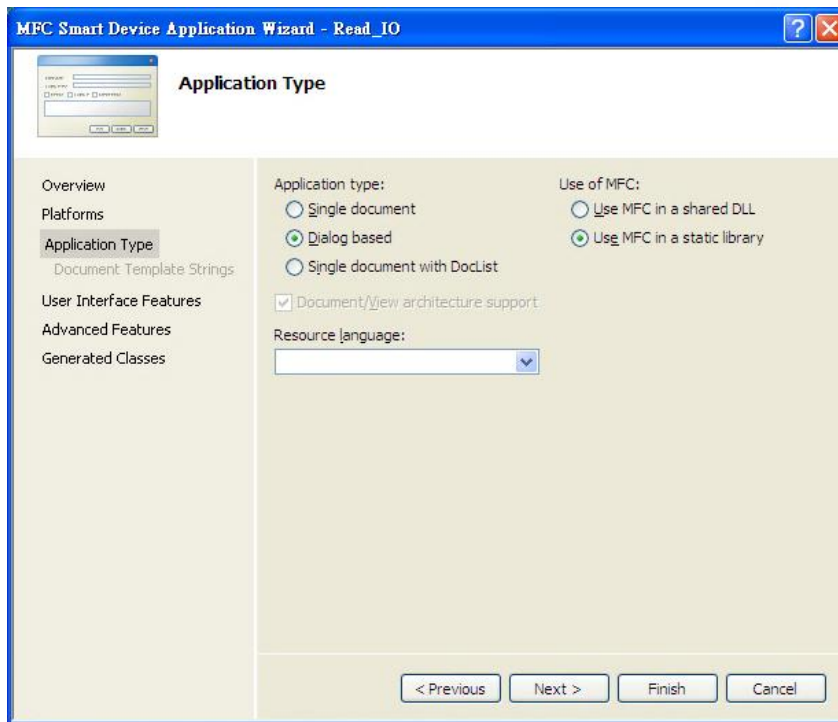

**Step 9** On the next page of the wizard, click next

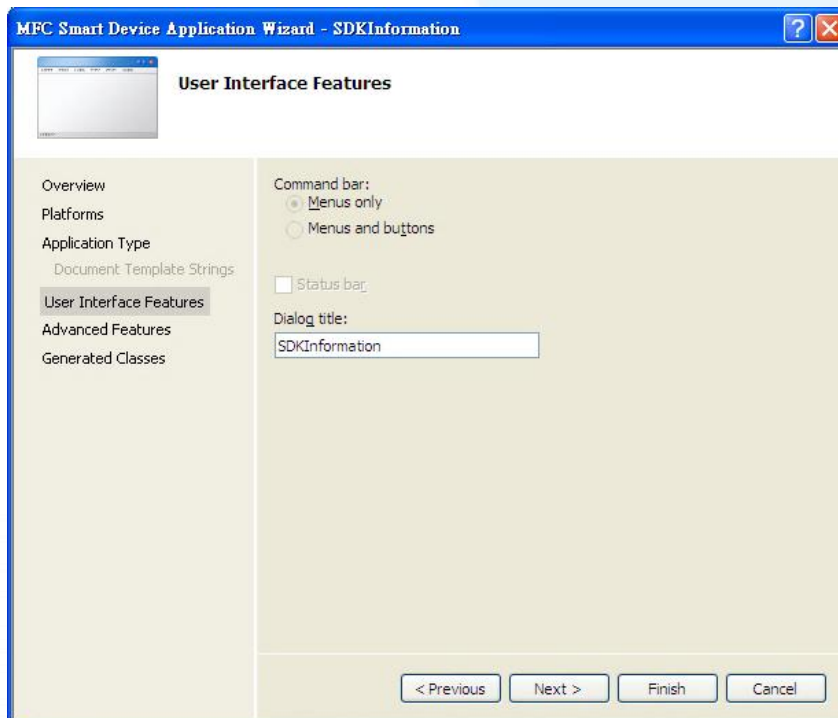

## Step 10 On the next page of the wizard, click next

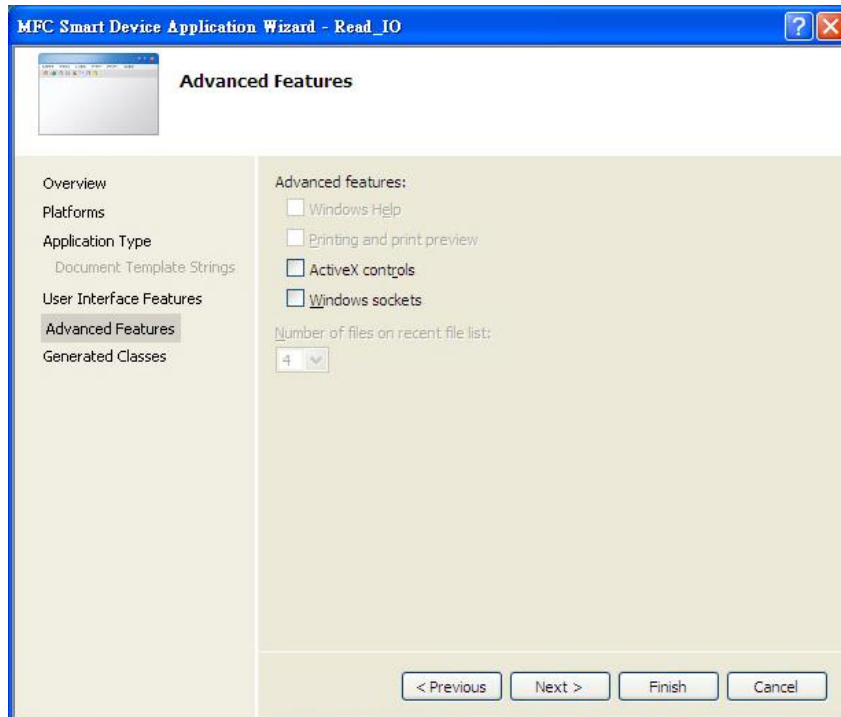

## Step 11 On the next page of the wizard, click Finish

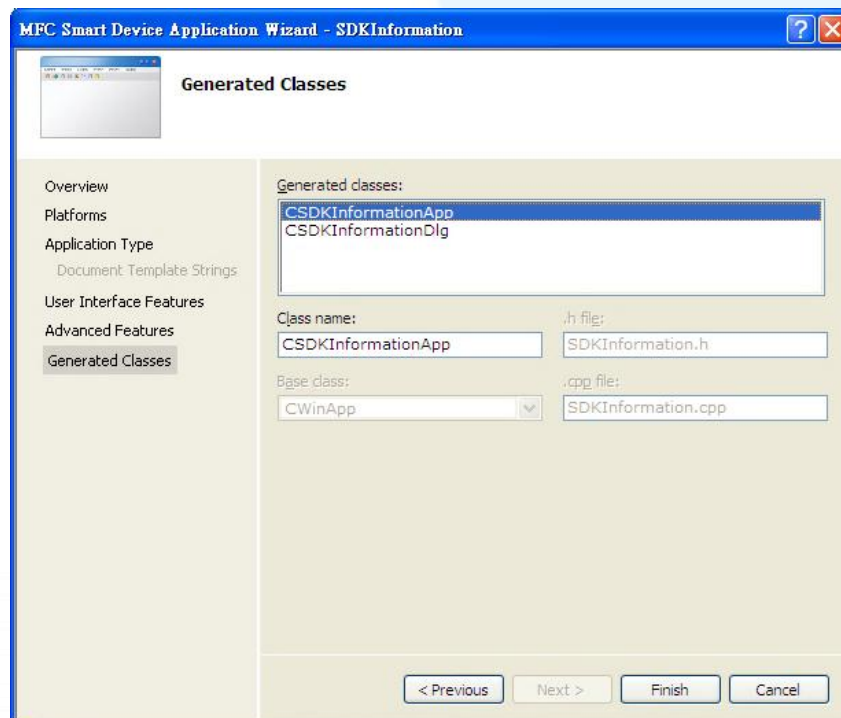

### 4.3.3.2. Configuring the Platform

When developing applications by using Visual C++, you must configure the Platform to indicate what platform and device you intend to download the application to. Before you deploy your project, check the platform.

On the Debug configuration toolbar, select Release, and then on the Pocket PC 2003 (ARMV4) configuration toolbar, select XPacSDK\_CE (x86), as shown in the following illustration.

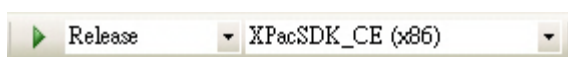

### 4.3.3.3. Specifying the Path of the XPAC Reference

The XPAC SDKs provides a complete solution to integrate with XPAC and it's compatible with Visual C#, Visual Basic .net and C++. In order to use a component in your application, you must first add a reference to it.

#### Step 1 Right-click the project name, and then click Properties

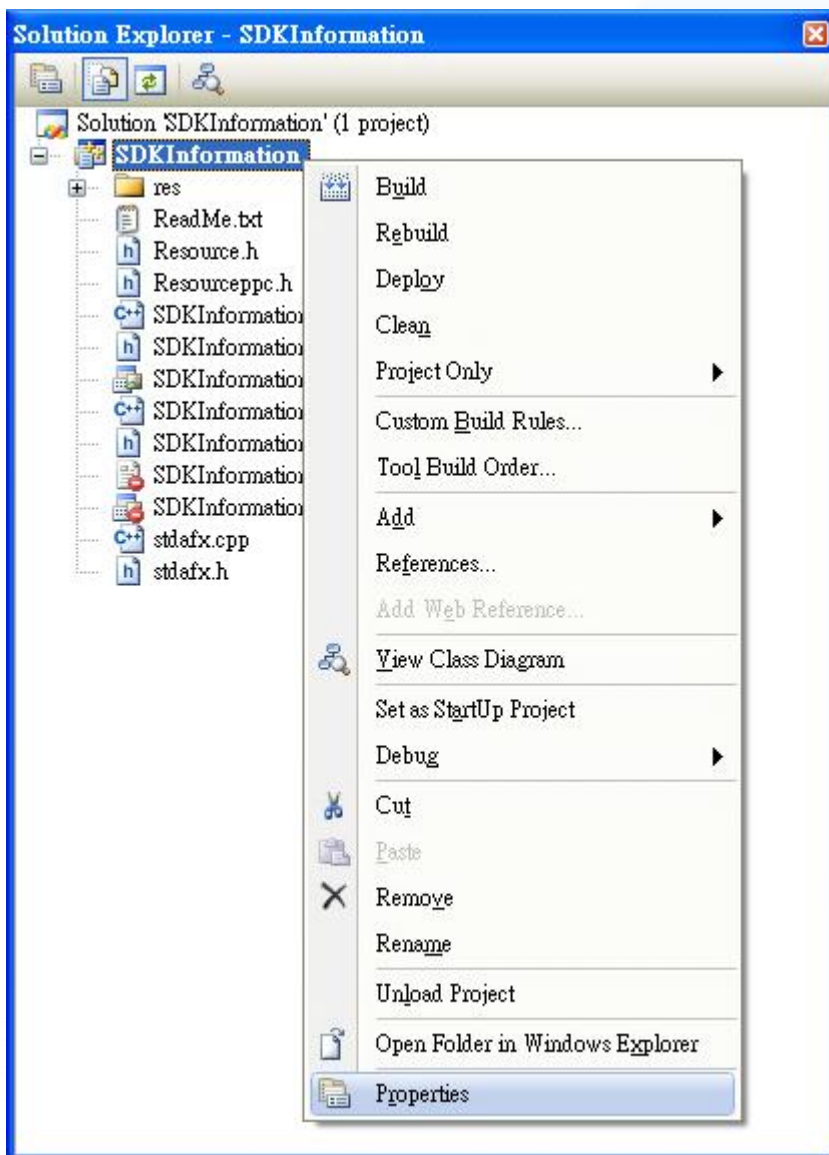

**Step 2** In left pane, expand Configuration Properties, and then click Link

**Step 3** In the right pane, choose the XPacSDK\_CE.lib in the Additional Dependencies item

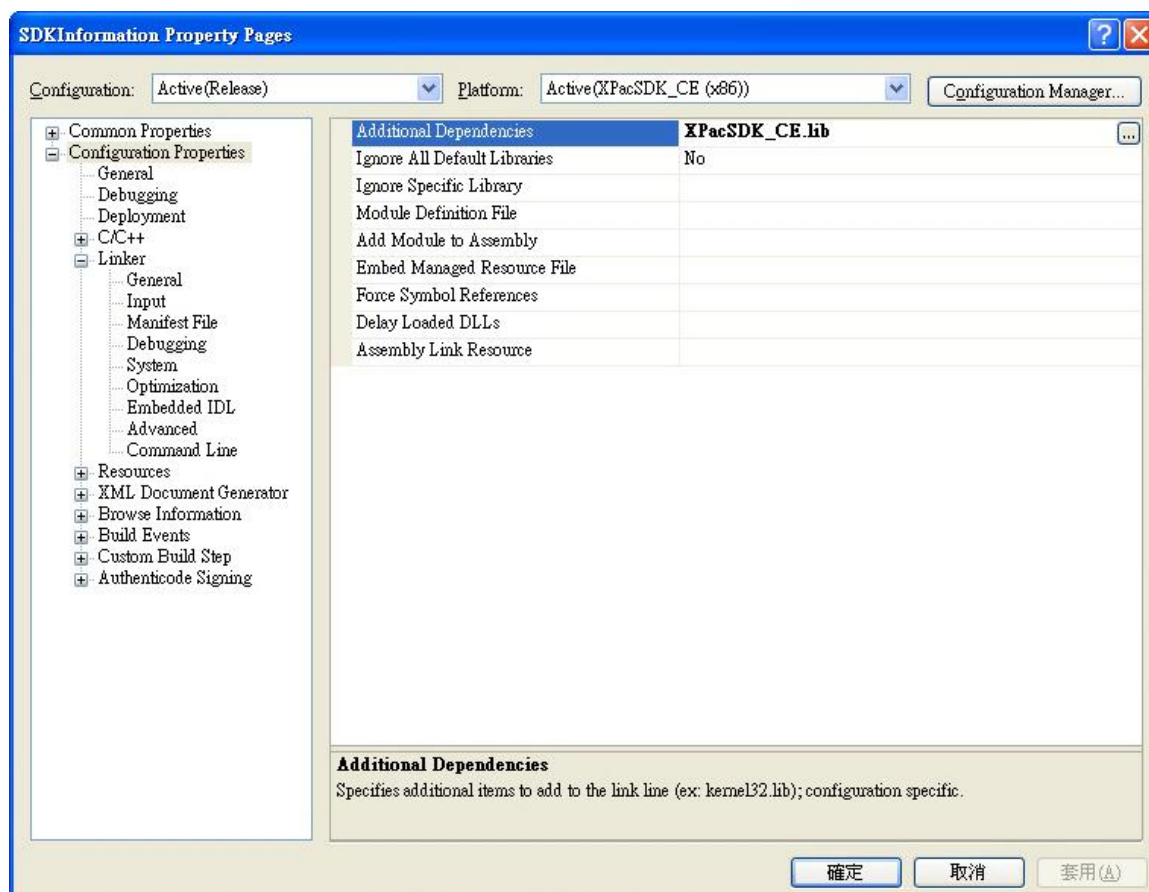

### 4.3.3.4. Adding the Control to the Form

You can drag various controls from the Toolbox onto the form. These controls are not really "live"; they are just images that are convenient to move around on the form into a precise location.

After you add a control to your form, you can use the Properties window to set its properties, such as background color and default text. The values that you specify in the Properties window are the initial values that will be assigned to that property when the control is created at run time.

**Step 1** In Resource View, expand the resources tree by opening the top level folder

**Step 2** Open the Dialog folder and then double-click the dialog resource name `IDD_SDKINFORMATION_DIALOG`

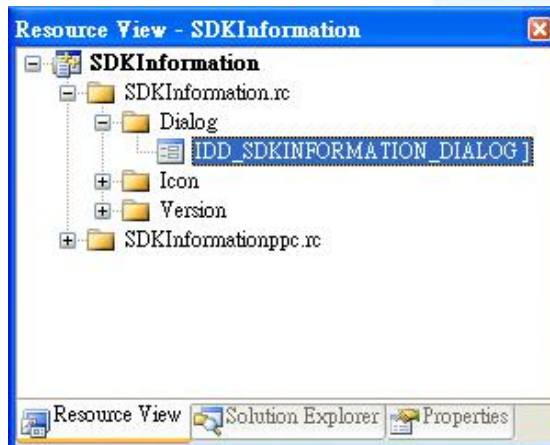

The resource editor appears in the right pane.

### Step 3 From the Toolbox, drag a Button control onto the form

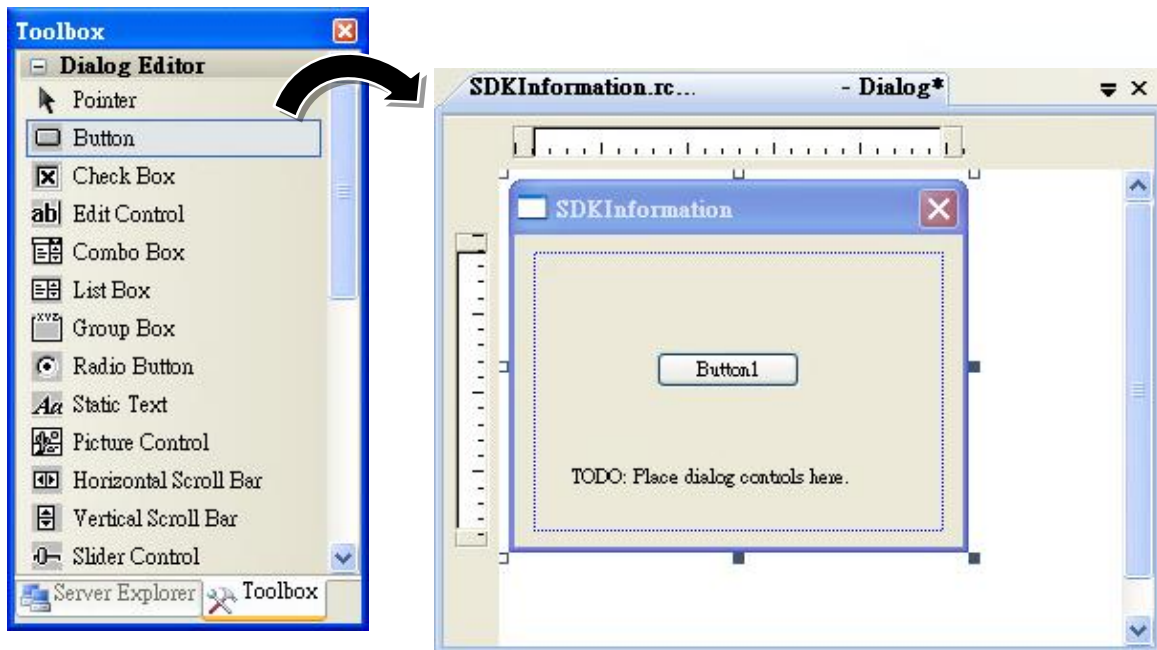

### Step 4 Right-click the Button control, and then click Properties

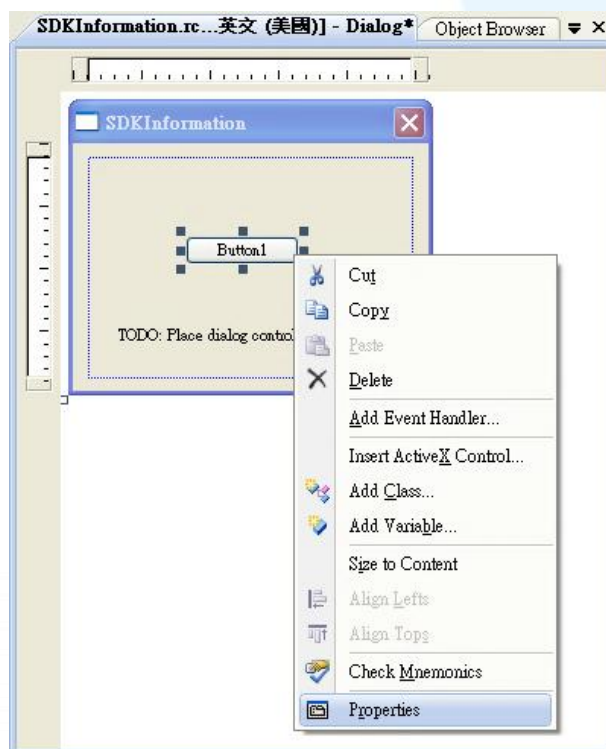



**Step 5** In the Properties window, type **Check the SDK version**, and press **ENTER** to set the **Text** property

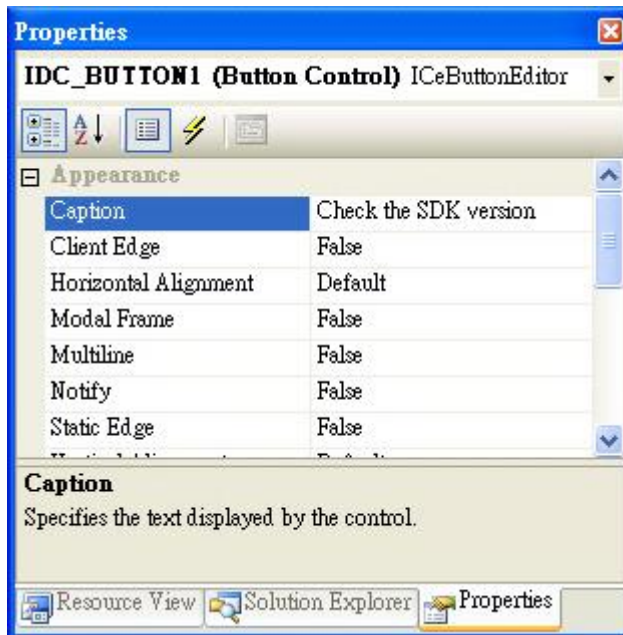



### 4.3.3.5. Adding the Event Handling to the Control

You have finished the design stage of your application and are at the point when you can start adding some code to provide the program's functionality.

#### Step 1 Double-click the button on the form

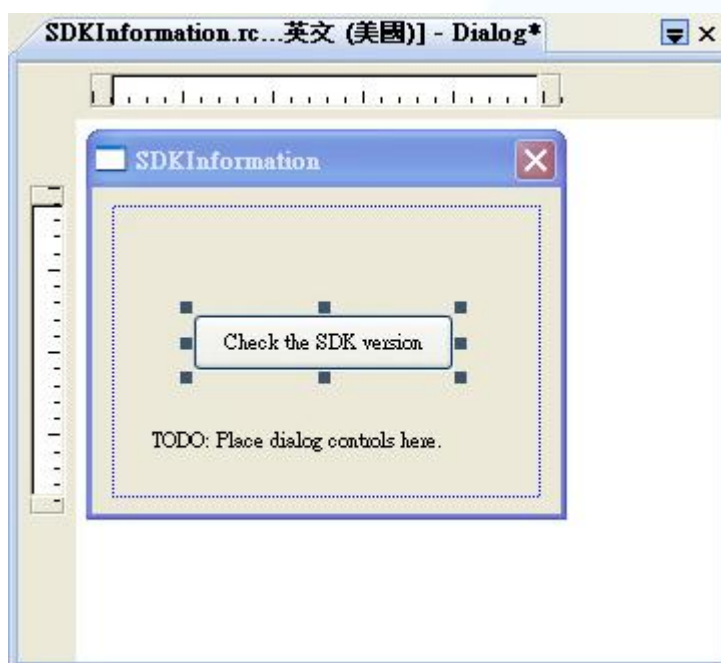

## Step 2 Inserting the following code

```
char sdk_version[32];
TCHAR buf[32];
pac_GetSDKVersion(sdk_version);
pac_AnsiToWideString(OS, buf);
MessageBox(buf,0,MB_OK);
```

```
void CSDKInformationDlg::OnBnClickedButton1()
{
    char sdk_version[32];
    TCHAR buf[32];
    pac_GetSDKVersion(sdk_version);
    pac_AnsiToWideString(OS, buf);
    MessageBox(buf,0,MB_OK);

    // TODO: Add your control notification handler code here
}
```

## Step 3 Inserting the following code into the header area

```
#include "XPacSDK_CE.h"
```

```
// SDKInformationDlg.cpp : implementation file
//
#include "stdafx.h"
#include "SDKInformation.h"
#include "SDKInformationDlg.h"

#include "XPacSDK_CE.h"

#ifdef _DEBUG
#define new DEBUG_NEW
#endif
```

### 4.3.3.6. Uploading the Application to XP-8000-Atom-CE6

XP-8000-Atom-CE6 provide FTP server service, you can upload files to XP-8000-Atom-CE6 or download files from a public FTP server.

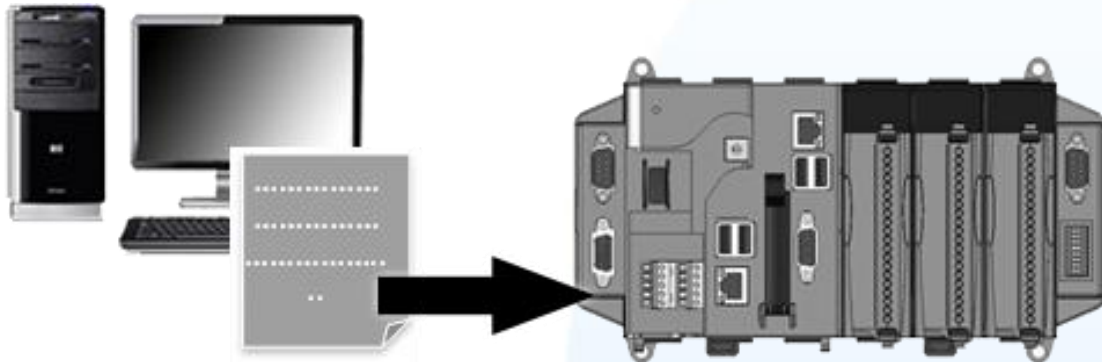

#### Step 1 On the Build menu, click Build SDKInformation

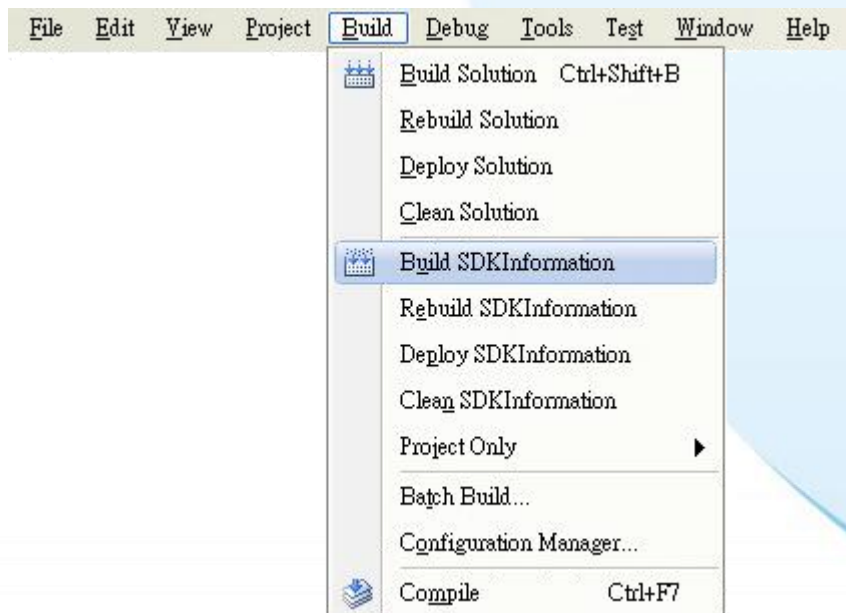

**Step 2** Open the browser and type the IP address of XP-8000-Atom-CE6

**Step 3** Upload the SDKInformation.exe application



### **4.3.3.7. Executing the Application on XP-8000-Atom-CE6**

After uploading the application to XP-8000-Atom-CE6, you can just double-click it on XP-8000-Atom-CE6 to execute it.

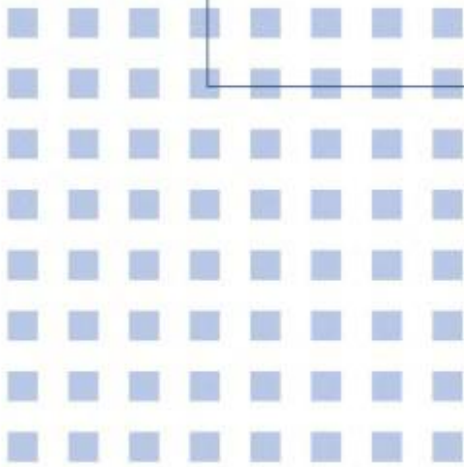
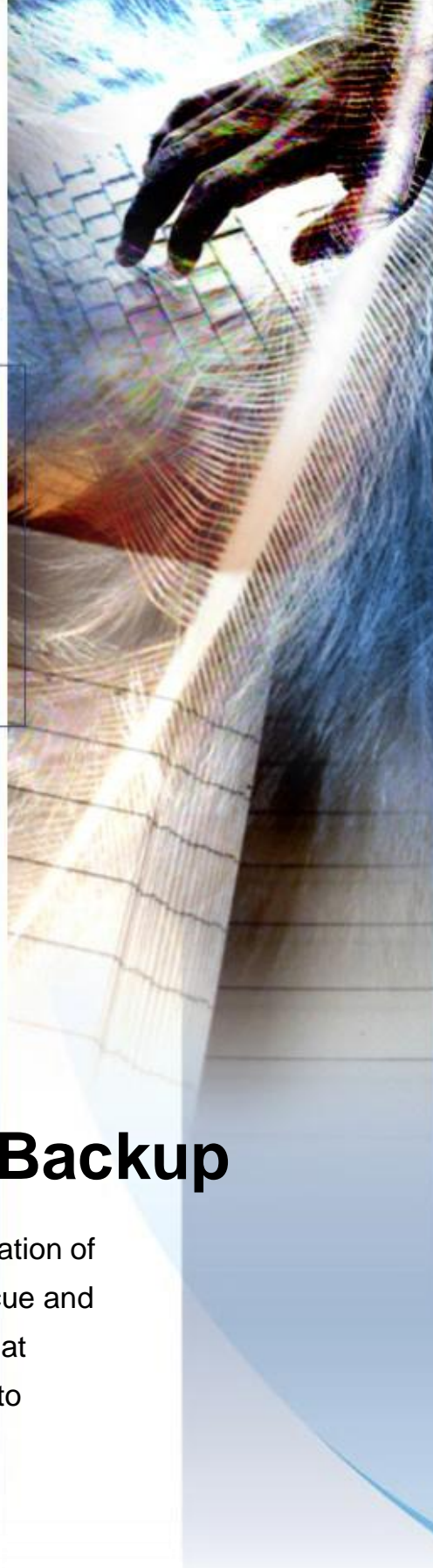

## 5. Rescue and Backup

This chapter provides information of the XP-8000-Atom-CE6 rescue and backup, and a guided tour that describes the steps needed to rescue and backup the XP-8000-Atom-CE6.

The XP-8000-Atom-CE6 comes with a rescue CF card that is a tool that you can use to boot the XP-8000-Atom-CE6 in the event that the operating system on the XP-8000-Atom-CE6 fails to start.

The rescue file of the rescue CF card can be found separately on the CD that was provided with the package or by downloading the latest version from ICP DAS web site.

#### Rescue CF Card

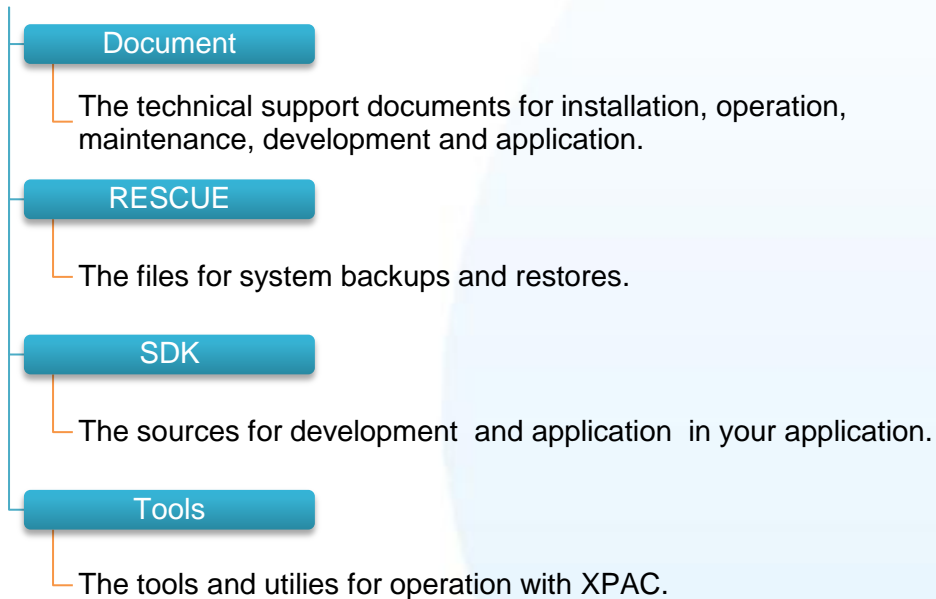

There is a ghost file, Atom\_Rescue\_Disk.gho that is used to restore the rescue CF card if it has partitioned or formatted.

The Atom\_Rescue\_Disk.gho file can be found from the CD that was provided with the package or by downloading the latest version from ICP DAS web site.

CD:\XPAC-ATOM-CE6\Rescue\_Disk\

[ftp://ftp.icpdas.com/pub/cd/xpac-atom-ce6/rescue\\_disk/](ftp://ftp.icpdas.com/pub/cd/xpac-atom-ce6/rescue_disk/)

# 5.1. Restoring the XP-8000-Atom-CE6

The XP-8000-Atom-CE6 comes with a rescue CF card that is a tool that allows users to restore the XP-8000-Atom-CE6 to factory default settings by reinstalling the XP-8000-Atom-CE6 OS image. If the XP-8000-Atom-CE6 crashes and won't start up, you can use the rescue CF card to start up the XP-8000-Atom-CE6 computer and then fix the problem that caused the crash.

Here are step by step instructions on how to restore the XP-8000-Atom-CE6.

## Step 1 Place the rotary switch in position 0, Normal mode

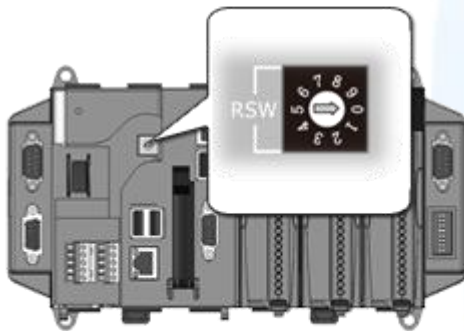

## Step 2 Reboot the XP-8000-Atom-CE6 and go to the BIOS by pressing the DEL key

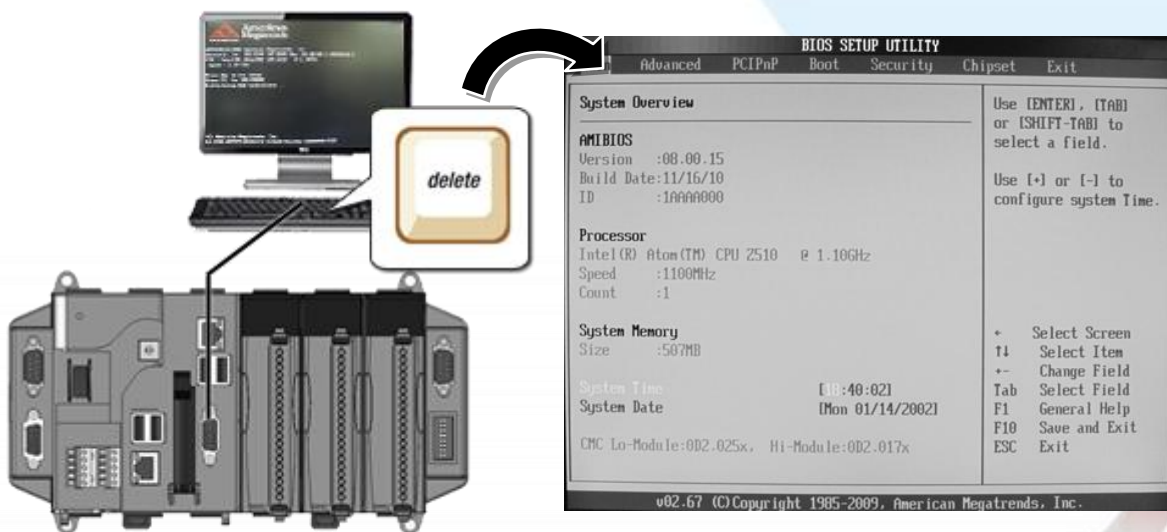



### Step 3 Select Boot menu, and then select Hard Disk Drives

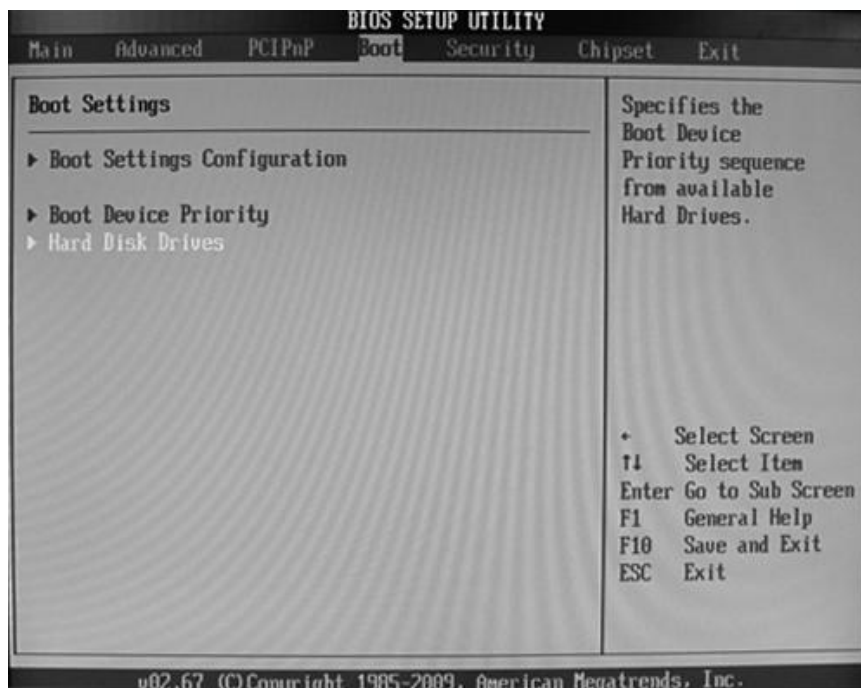

### Step 4 Set 1st Drive as PS-Flash Module, PS-Flash Module means compact CF card

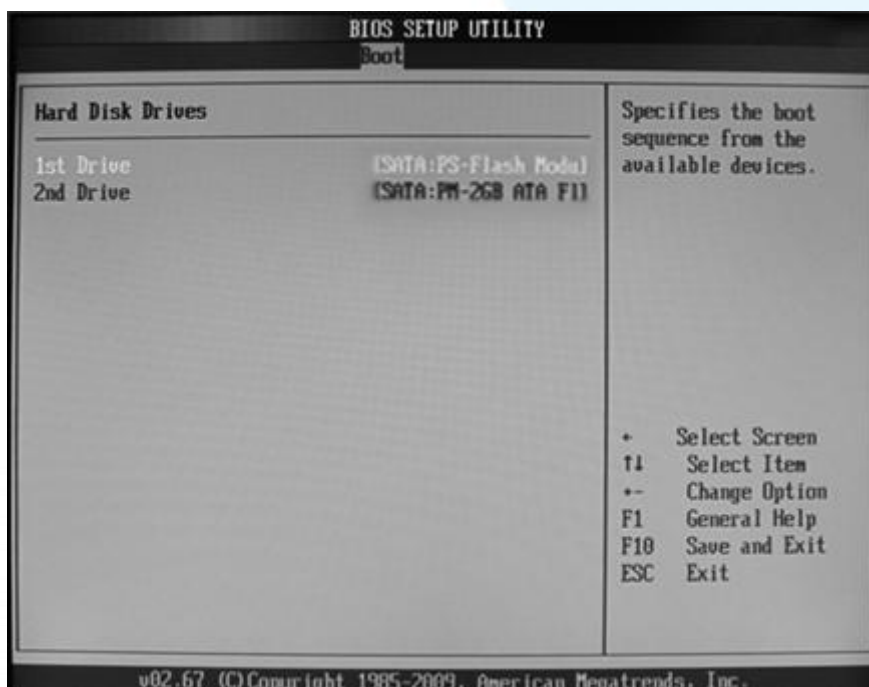

## Step 5 Press F10 to save and exit setup



## Step 6 After restarting, the system will enter the XP-8000-Atom-CE6 Rescue Utility, and then enter (1), create XPAC\_CE default partition

```
=====
==                               Main Menu                               ==
=====

**  the following 3 steps help you  **
**  restore default XPAC_CE OS.    **

(1) Step 1: create XPAC_CE default partition.
(2) Step 2: format and restore XPAC_CE to factory default OS.
(3) Step 3: reboot

(6) Display directory information on built-in flash
```

Please enter your choice:

**Step 7** Wait a while until we enter the XP-8000-Atom-CE6 Rescue Utility again, and then enter (2), format and restore XPAC\_CE to factory default OS

**Step 8** Wait a while until we enter the XP-8000-Atom-CE6 Rescue Utility again, and then enter (3), reboot

**Step 9** Repeat step 1 ~ 4 to set 1st Drive as PM-2GB-ATA F1, PM-2GB-ATA F1 means Built-in flash, and then reboot the XP-8000-Atom-CE6

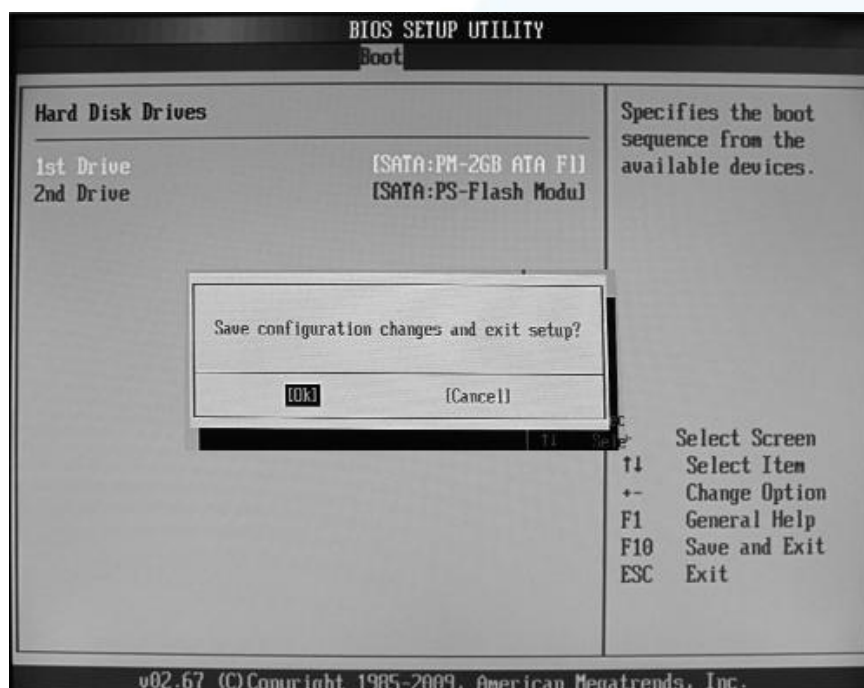

**Step 10** The XP-8000-Atom-CE6 will take about 8 minutes to complete the process

## 5.2. Restoring the Rescue CF Card

The rescue CF card is rescue equipment that allows you to perform some maintenance tasks on your system in case of failure.

Once the rescue CF card are partitioned or formatted, you must restore the rescue CF card.

### Requirements

For restoring the Rescue CF card, you should prepare Ghost 11 or later, which you could obtain by contacting Symantec (<http://www.symantec.com>)

Here are step by step instructions on how to restore the rescue CF card. In this demonstration, we will use Symantec Norton Ghost32 V.11 (The Symantec Norton Ghost V.11 or above version are recommend).

### Step 1 Get the rescue ghost file, Atom\_Rescue\_Disk.gho

The Atom\_Rescue\_Disk.gho file can be installed from the CD that was provided with the package or by downloading the latest version from ICP DAS web site.

CD:\XPAC-ATOM-CE6\Rescue\_Disk\

[ftp://ftp.icpdas.com/pub/cd/xpac-atom-ce6/rescue\\_disk/](ftp://ftp.icpdas.com/pub/cd/xpac-atom-ce6/rescue_disk/)

**Step 2 Start the Symantec Norton Ghost32 V.11, and then click OK**

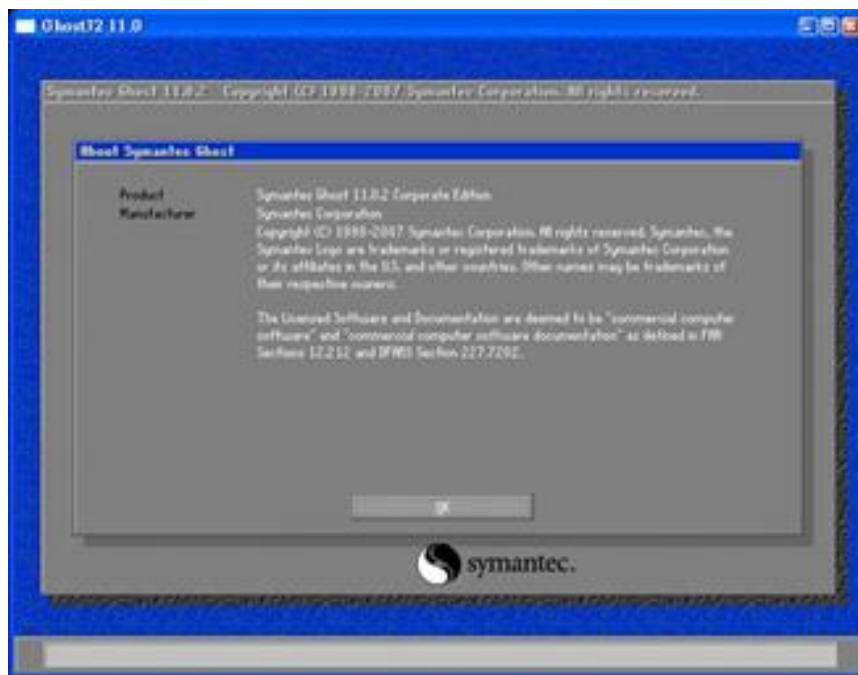

**Step 3 Click Function Menu, point to Local, point to Disk, and then click From Image**



**Step 4** Select rescue ghost file, Atom\_Rescue\_Disk.gho, that you saved and then click Open

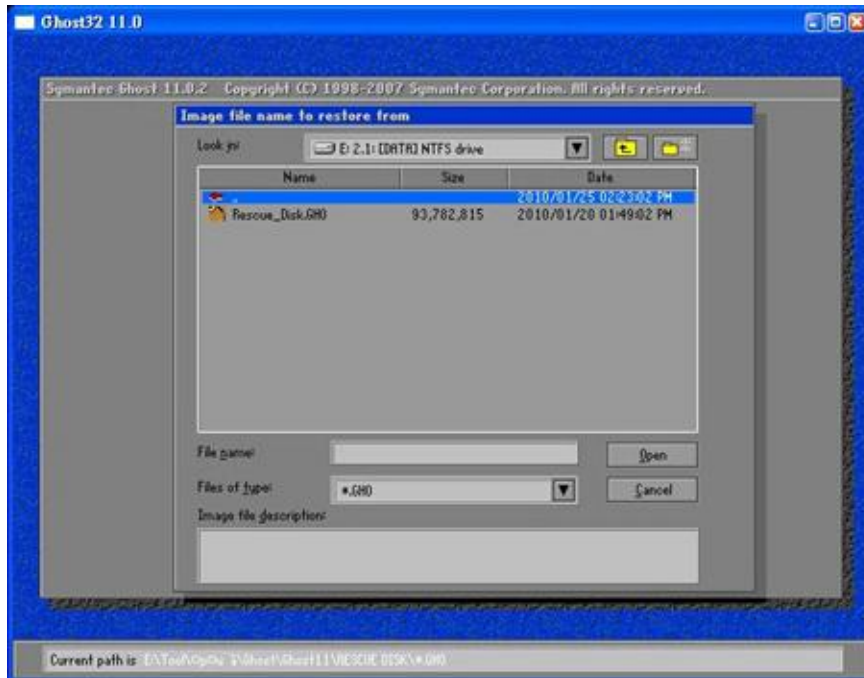

**Step 5** Select the destination to CF card and click then OK





**Step 6** Recovery the rescue ghost file, Atom\_Rescue\_Disk.gho, into CF card and then click OK

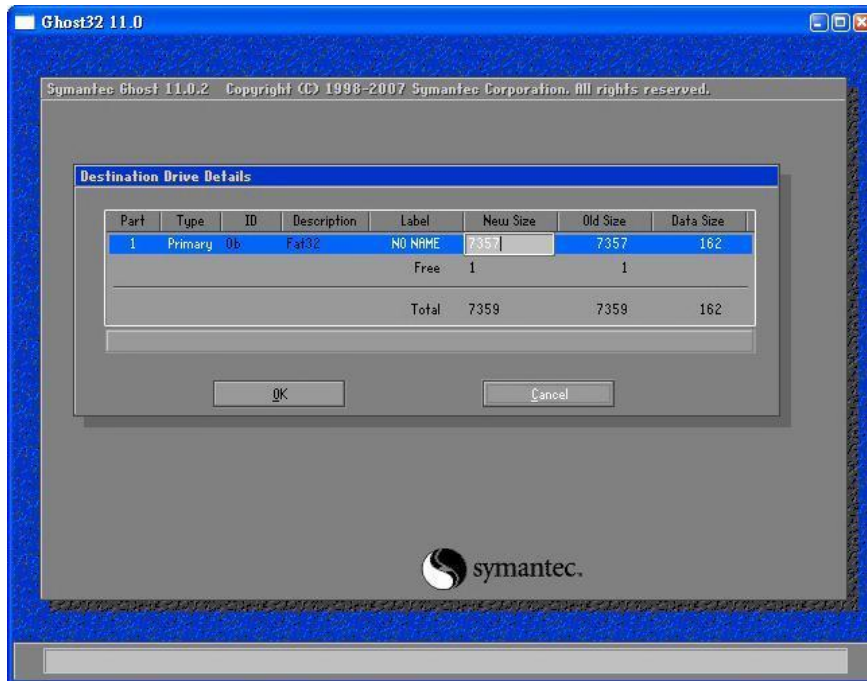

**Step 7** The rescue CF card has been done

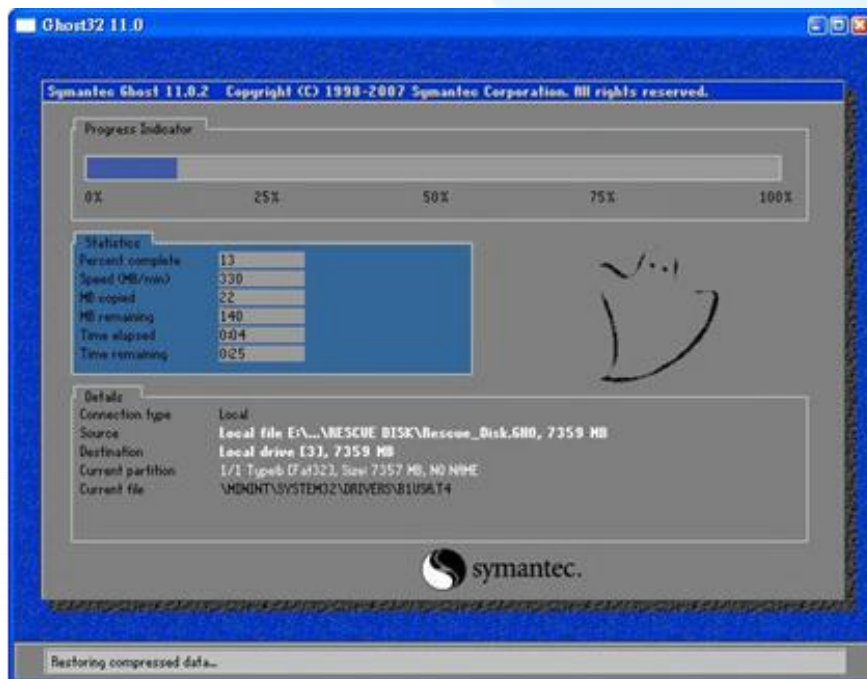

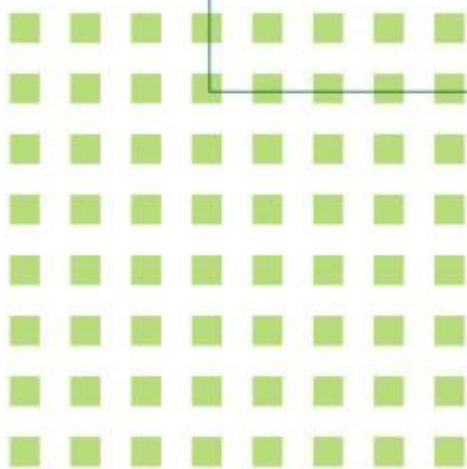
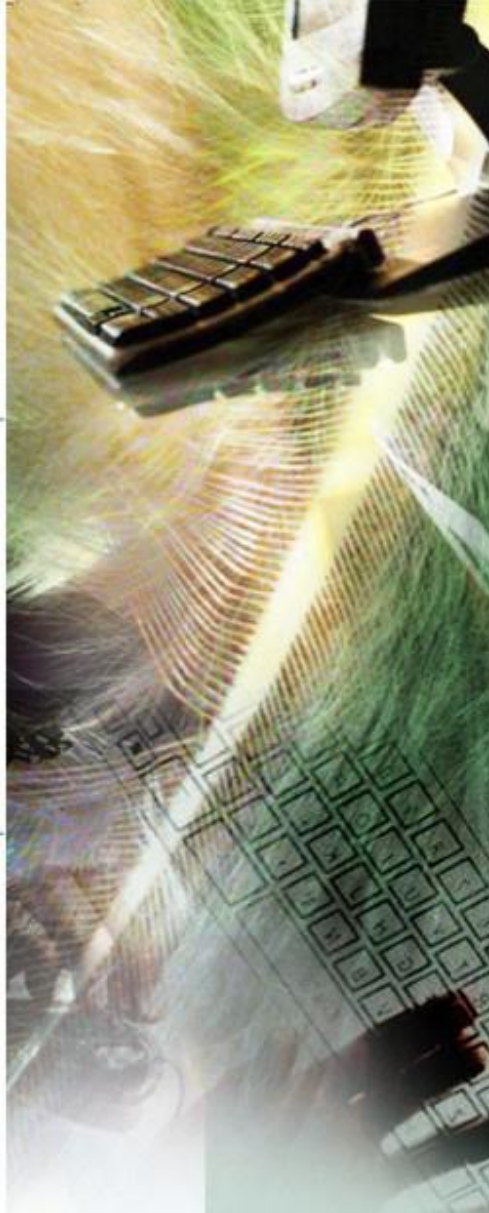

## 6. XP-8000-Atom-CE6 Updates

This chapter provides information of the XP-8000-Atom-CE6 OS and firmware, and a guided tour that describes the steps needed to update the XP-8000-Atom-CE6 OS or firmware.



ICP DAS will continue to add additional features to XP-8000-Atom-CE6 SDK and OS in the future, so we advise you to periodically check the ICP DAS web site for the latest updates.

XP-8000-Atom-CE6 updates services provides a software update service for XP-8000-Atom-CE6. It can be divided into two categories, OS updates and SDK updates.

Both the OS updates services and SDK updates services can be found separately on the CD that was provided with the package or by downloading the latest version from ICP DAS web site.

CD:\XPAC-ATOM-CE6\  
ftp://ftp.icpdas.com/pub/cd/xpac-atom-ce6/

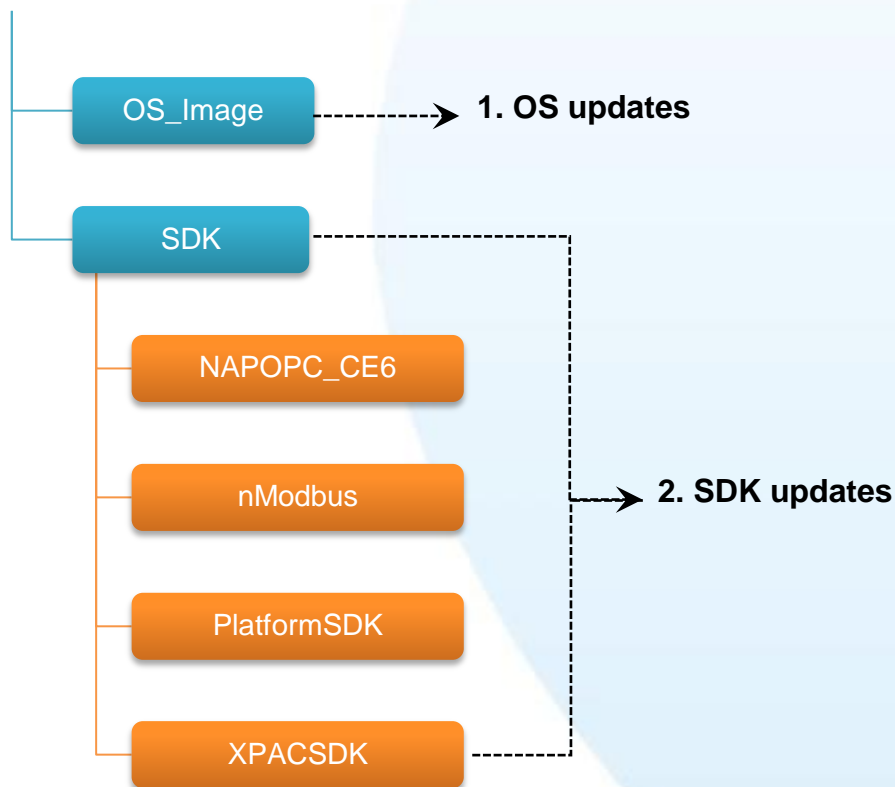

## 6.1. OS updates

OS updates are part of the XP-8000-Atom-CE6 updates services to provide additional and more efficient features and functionality for XP-8000-Atom-CE6 operating system.

There are two ways to update the OS:

1. Update from file (Please refer to section 7.1.1)

(We recommend that you use this one for more quicker and easier to update)

2. Update from rescue CF card (Please refer to section 7.1.2)

## 6.1.1. OS Updates from Files

Here are step by step instructions on how to update the XP-8000-Atom-CE6 OS.

### Step 1 Get the latest version of the XP-8000-Atom-CE6 OS image, NK.BIN

The latest version of the XP-8000-Atom-CE6 OS image, NK.BIN, can be obtained from ICP DAS web site.

<ftp://ftp.icpdas.com/pub/cd/xfac-atom-ce6/rescue/ce6/>

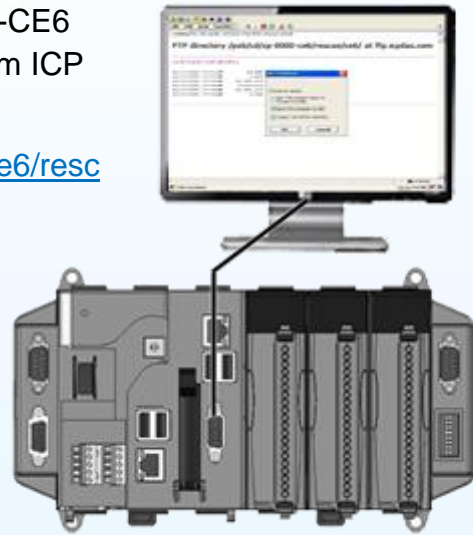

### Step 2 Replace the order XP-8000-Atom-CE6 OS image

The XP-8000-Atom-CE6 OS image, NB.BIN are pre-installed on the XP-8000-Atom-CE6, located under \System\_Disk

### Step 3 Reboot the XP-8000-Atom-CE6, the XP-8000-Atom-CE6 OS image has been updated completely

## 6.1.2. OS Updates using the Rescue CF Card

The XP-8000-Atom-CE6 can be reinstalled with the XP-8000-Atom-CE6 Rescue Utility. Before reinstalling the XP-8000-Atom-CE6, make sure the necessary updating files have been are available on your CF card.

For more information on how to reinstall the XP-8000-Atom-CE6, please refer to section 6.1. Recovering the XP-8000-Atom-CE6

## 6.2. SDK updates

SDK updates are part of the XP-8000-Atom-CE6 updates services to provide additional and more efficient features and functionality for XP-8000-Atom-CE6 applications.

Here are step by step instructions on how to update the XPAC SDK.

### **Step 1 Get the latest version of the XPAC SDK components**

The latest version of the XPAC SDK components can be obtained from ICP DAS web site.

<ftp://ftp.icpdas.com/pub/cd/xpac-atom-ce6/sdk/>

### **Step 2 Copy the latest version of DLL to PC and XPAC**

The DLL files on PC are located at anywhere only the solution can reference it.

The DLL files on XP-8000-Atom-CE6 are located at the same directory as the .exe file.

## Appendix A. Application of RS-485 Network

This chapter provides tips and a guided tour on using and maintaining the XP-8000-Atom-CE6.

The RS-485 length can be up to 4000 ft or 1.2 km over a single set of twisted-pair cables, if the RS-485 network is over 4000 ft or 1.2Km, the RS-485 repeater must be added to extend the RS-485 network.

# A.1. Basic RS-485 Network

The basic component of the RS-485 network consist of a Master Controller (or using a PC as a host controller), and some RS-485 devices.

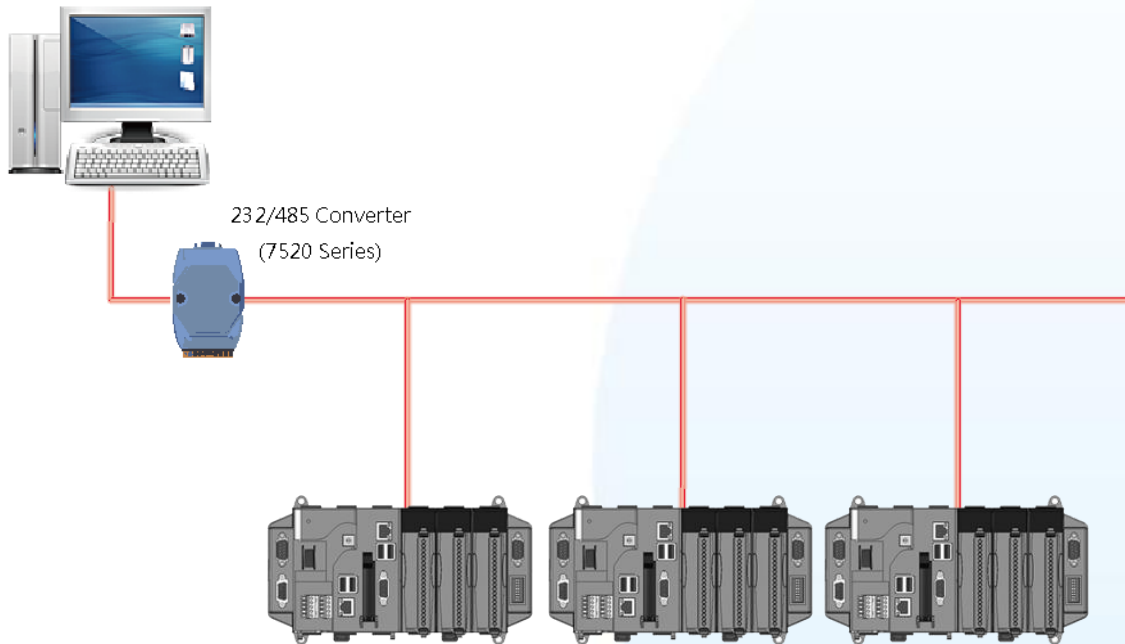



## A.2. Daisy Chain RS-485 Network

All RS-485 devices are wired directly to the main network, If the network is up to 1.2 km, it will need a repeater (7510 series) to extend the network length.

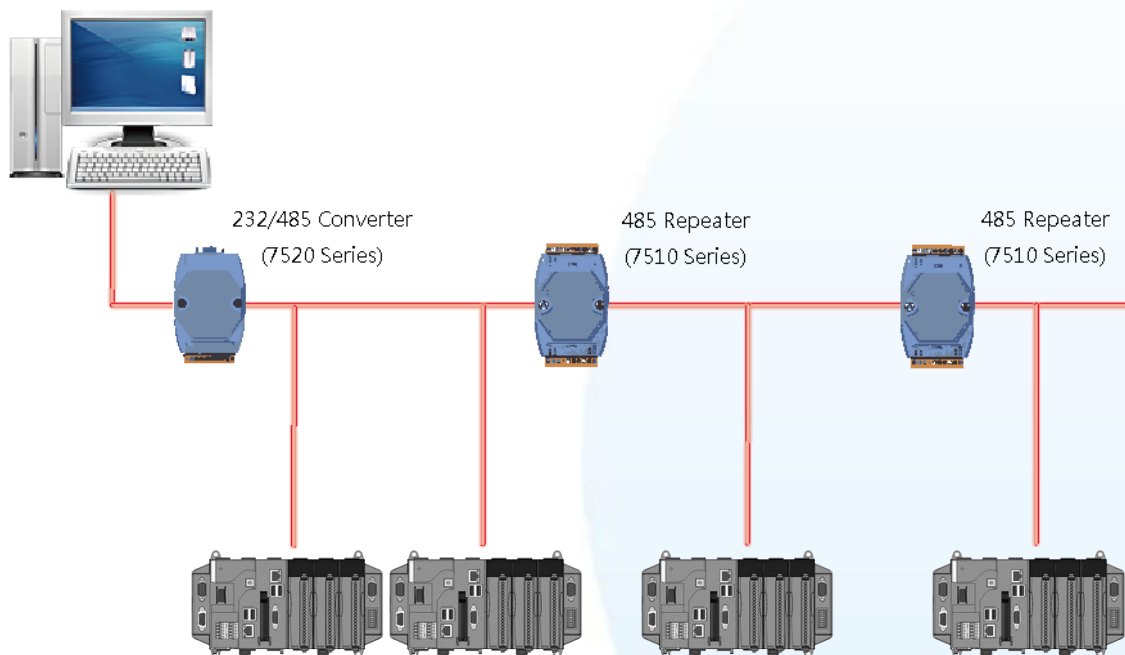

## A.3. Star Type RS-485 Network

There are branches along the main network. In this case, it is better to have a repeater to isolate or filter the noise that is made by devices.

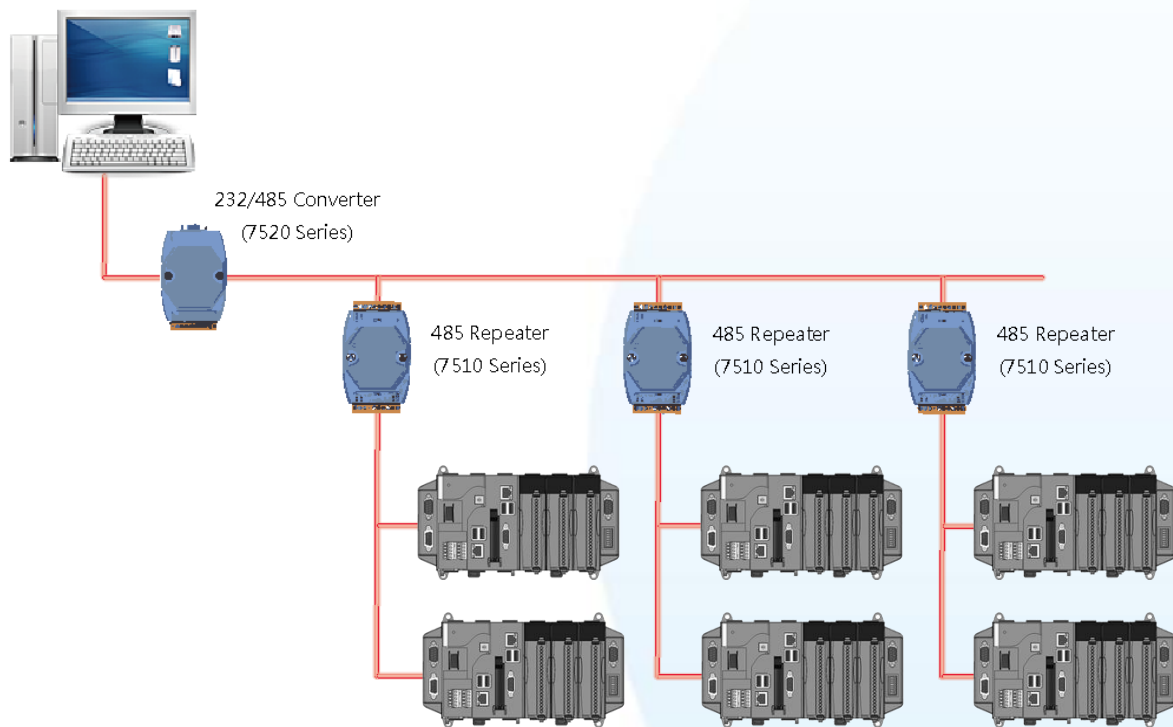

There is a better choice to use 7513 as a RS-485 hub on start type network.

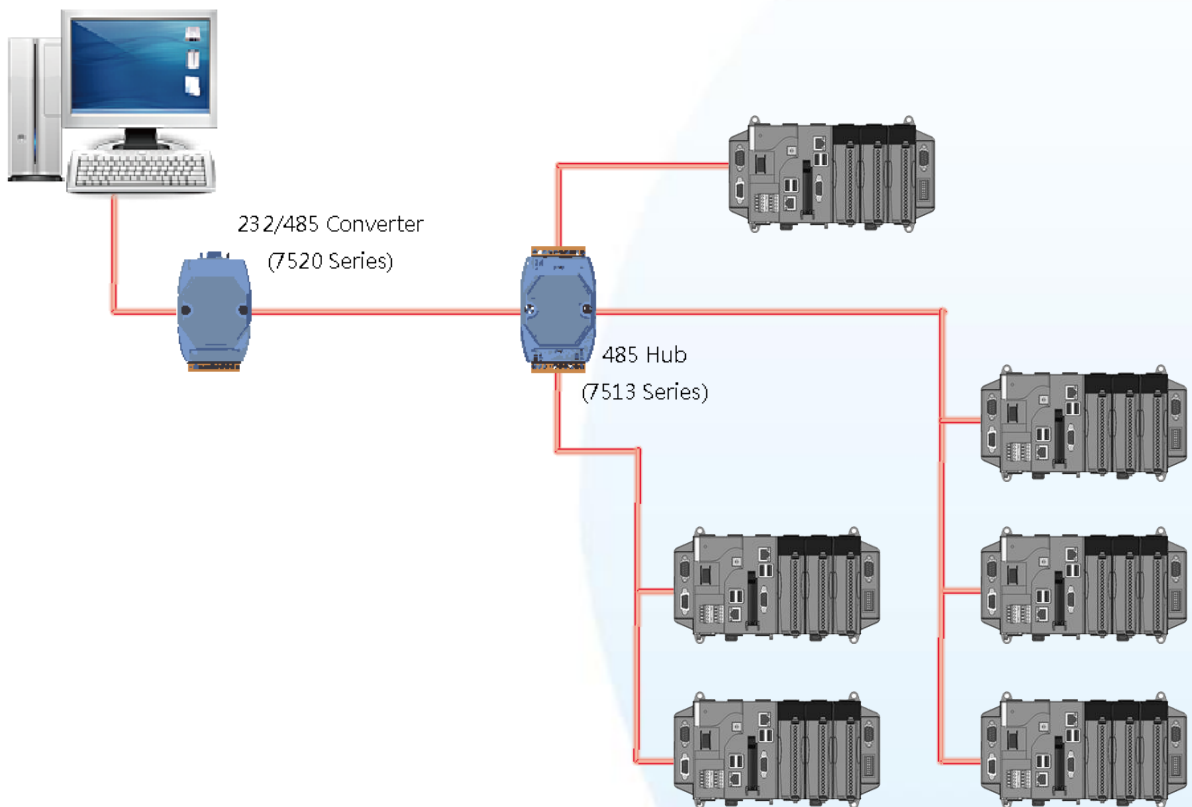

## A.4. Random RS-485 Network

There are branches along the main wire. In this case, it is better to have a repeater to isolate or filter the noise that is made by devices.

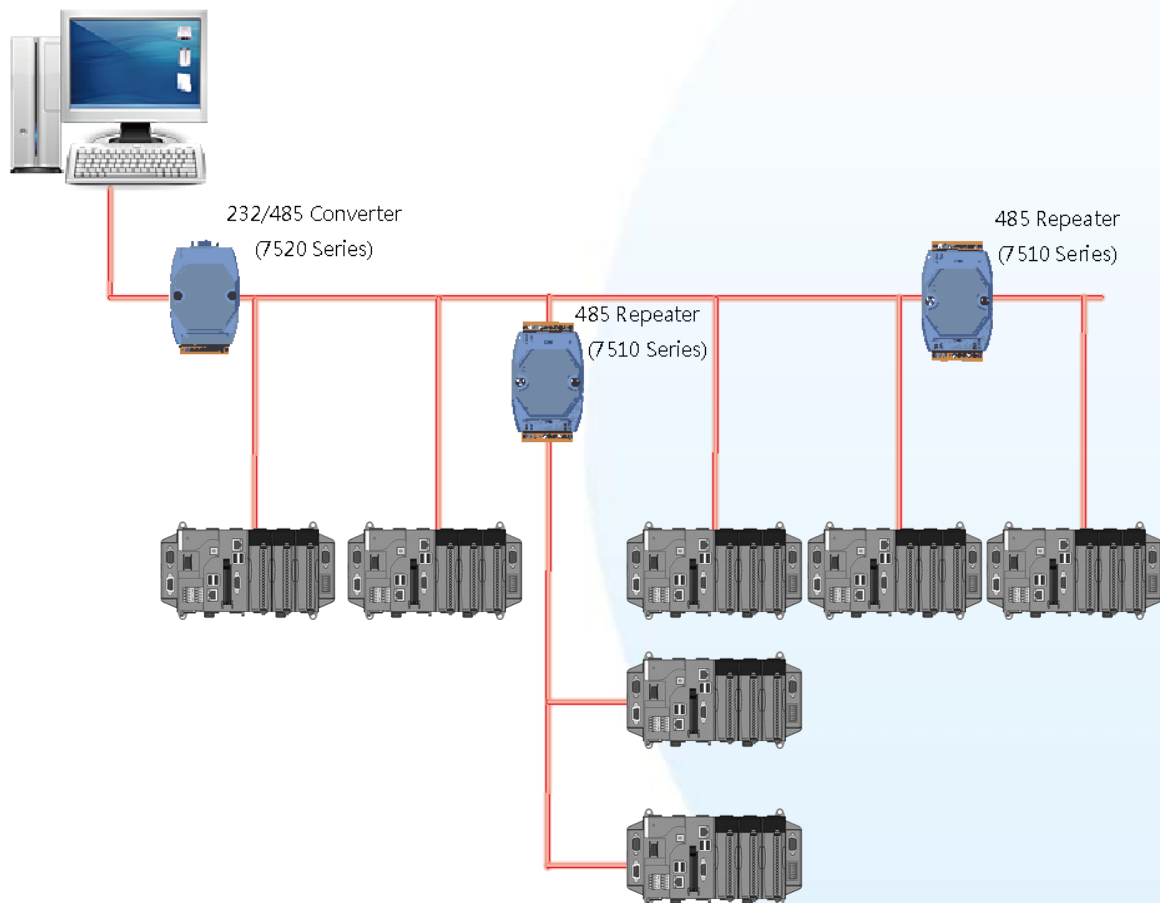

## A.5. Master/Slave Settings

The RS-485 network based on master-slave architecture consists of a single master device and one or more slave devices.

The XPAC provides two RS-485 communication interfaces based on the master-slave system architecture, all of which have a pull-high/pull-low resistor, user can set it to master or slave for implementing an RS-485 multi-drop network.

One of the RS-485 communications, COM3, its pull-high/pull-low resistor located on power board, the other, COM4, located on the right side and its pull-high/pull-low resistor located on the bottom of the right side, as shown below.

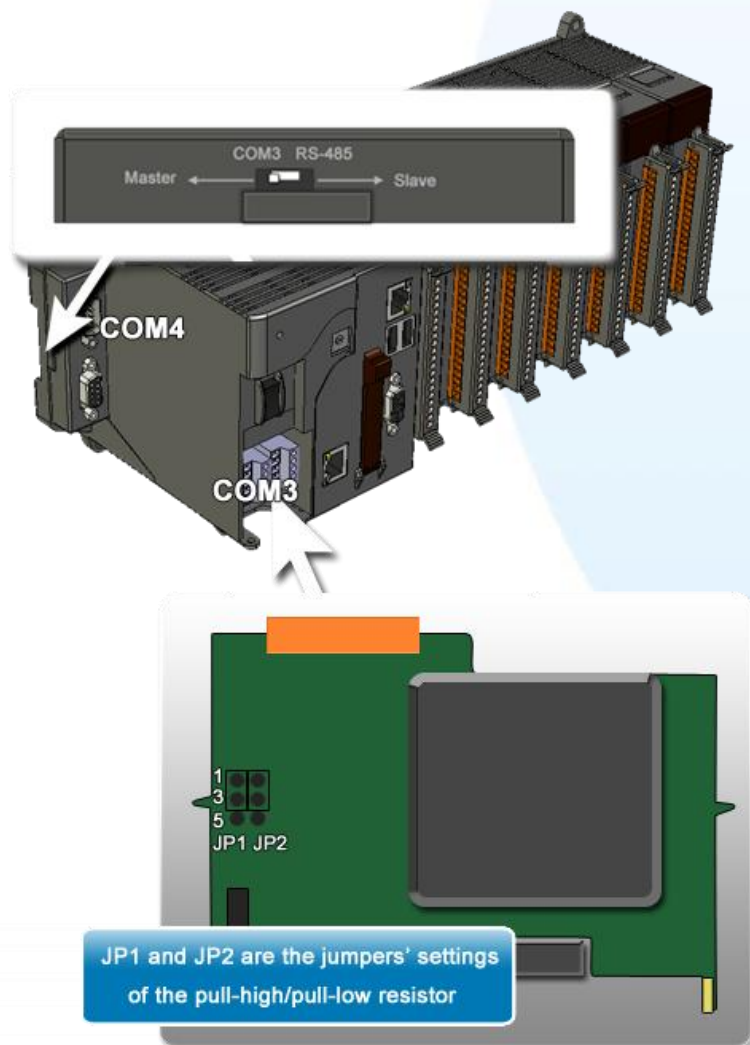

## A.1.1. XPAC as a Master (Default)

When one of XPAC is set to master, then all the other devices on the same network must be slave mode. If the network is up to 1.2 KM, it will need a repeater (7510 series) to extend the network length.

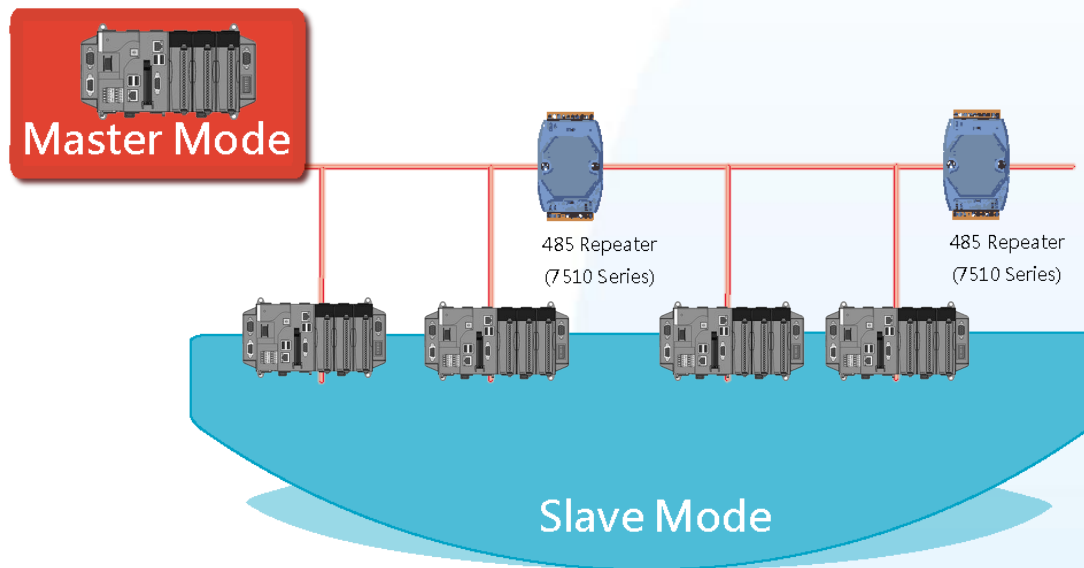

When XPAC as a master using COM3 communication interface, the pull-high/pull-low resistor located on the power board must adjust to enable as shown below.

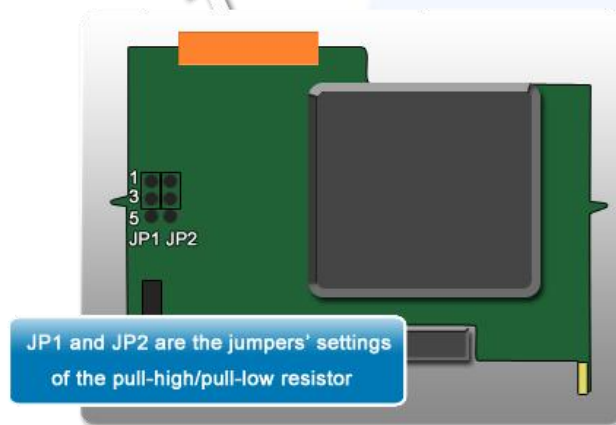
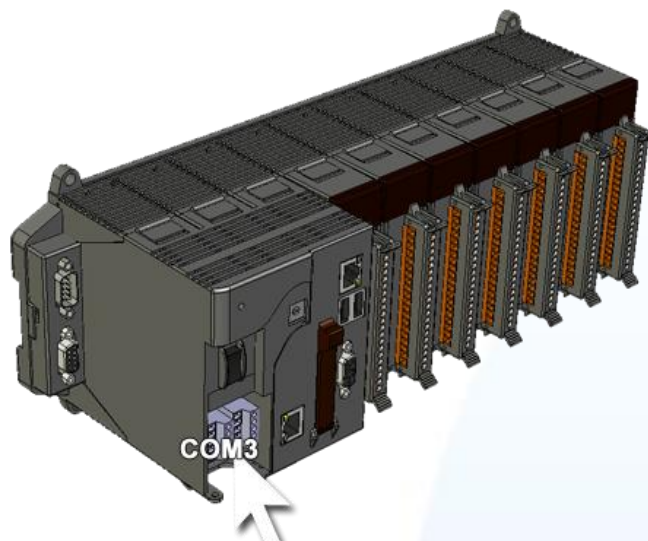

When XPAC as a master using COM4 communication interface, the pull-high/pull-low resistor located on the power board must adjust to enable as shown below.



## A.1.1. XPAC as a Slave

For most of application, when using one 7520 series as RS-232/485 converter, its pull-high/pull-low resistors are set to enabled. Then the XP-8000-Atom-CE6 and all the other devices on this network must be slave mode (the pull-high/pull-low resistors must be disabled).

If there are repeaters on the RS-485 network, there will be pull-high/pull-low resistors on both sides of the repeaters (I-7510)

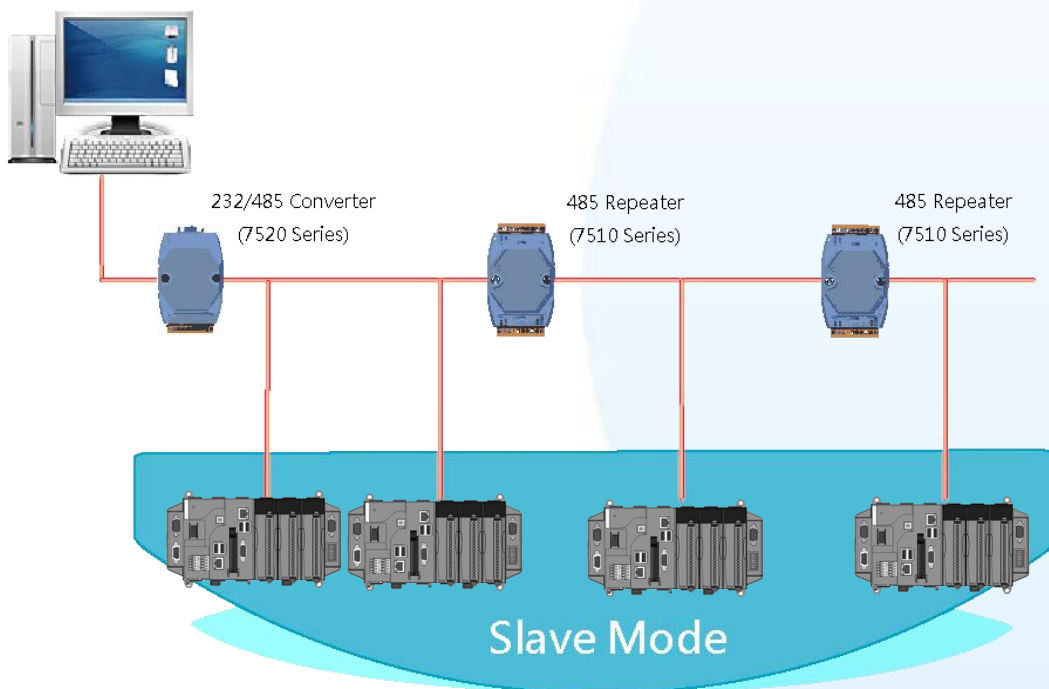



When XPAC as a master using COM3 communication interface, the pull-high/pull-low resistor located on the power board must adjust to enable as shown below.

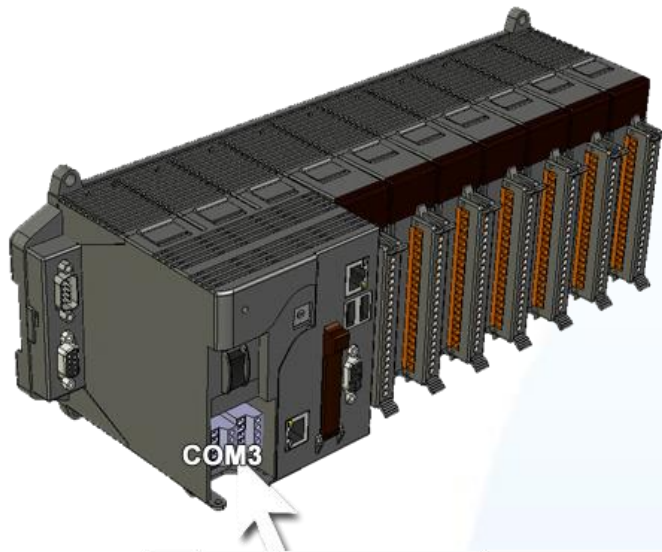

When XPAC as a master using COM4 communication interface, the pull-high/pull-low resistor located on the power board must adjust to enable as shown below.



# B

## Appendix B. Tips & FAQ

This chapter provides information to help you deploy and use XP-8000-Atom-CE6.

We will continue to add flexibility and support to the XP-8000-Atom that always can be found at:

CD:\XPAC\XPAC-ATOM-CE6\Document\faq\

<ftp://ftp.icpdas.com/pub/cd/xpac-atom-ce6/document/faq/>

The following section presents several common application of XP-8000-Atom.

The XP-8000 tips and FAQs can be categorized as follows:.

### **Ethernet Application**

How to set up the FTP server?

How to set up the Web server?

### **General IO Expansion**

How to use GSM/GPRS?

How to set up a printer?

How to set up an Egalax USB touch panel?

How to set up an ELO USB touch panel?

How to set up a Penmount USB touch panel?

How to set up an Egalax serial touch panel?

How to set up an ELO serial touch panel?

How to set up a Penmount serial touch panel?

How to calibrate an Egalax USB touch panel?

How to calibrate an ELO USB touch panel?

How to calibrate a Penmount USB touch panel?

How to calibrate an Egalax serial touch panel?

How to calibrate an ELO serial touch panel?

How to calibrate a Penmount serial touch panel?

How to link serial devices through RS-485?

How to set up a communication module I-8112/I-8114/I-8142/I-8144 uses MSA?

How to change the display type?

How to use wireless Ethernet solution?

## **NAPOPC Server**

How to optimize communication performance in NAPOPC\_CE6?

How to use ET-7000 modules in NAPOPC\_CE6?

How to use FRnet modules in NAPOPC\_CE6?

How to use ZigBee modules in NAPOPC\_CE6?

How to set up an Egalax USB touch panel?

## **System Maintenance**

How to find the system information?

How to recover the default factory settings?

How to add a shortcut to the desktop and programs?

How to change the Input Panel size?

How to enter character without a keyboard?

How to automatically hide the taskbar?

How to set the taskbar always on the top?

How to configure an authoritative time server in Windows server?

## **Troubleshooting**

Why do I cannot install SDK?

Why do I insert new I-8000 module but XPAC Utility can't find in Device tab?

## **Update Software**

How to update OS image?

# B1. How to use the Printer

XP-8000-Atom-CE6 have ability to access the printer, you can connect to the printer via Ethernet network or USB.

## Tips & Warnings

---



XPAC only supports HP Laser Jet Printers which support PCL6 driver.

---

## B.1.1. How to use the network printer

Here are step by step instructions on how to use a shared printer.

### Step 1 On PC side, check the name of the PC and the shared printer

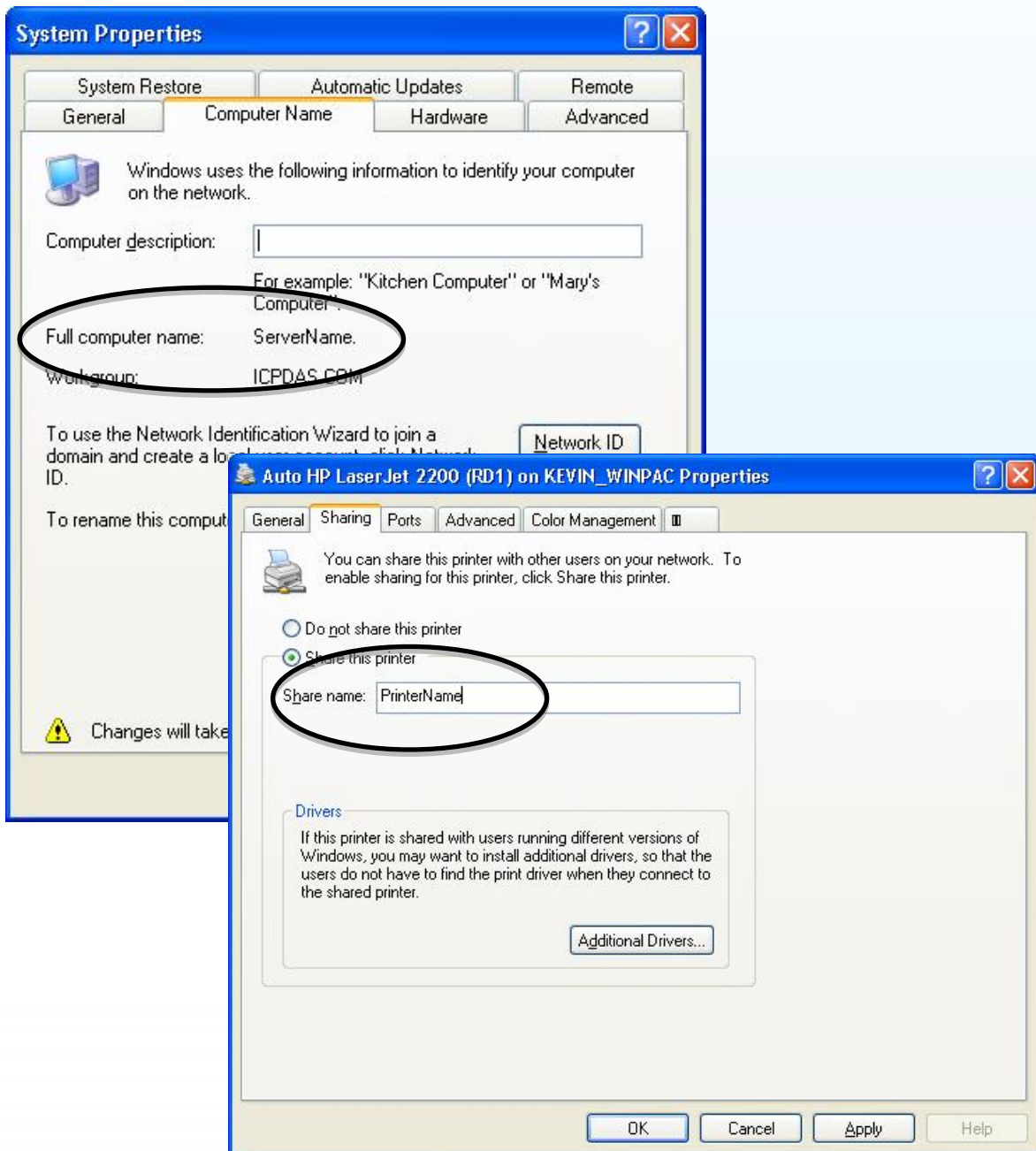



## Step 2 On XPAC side, open a WordPad format file

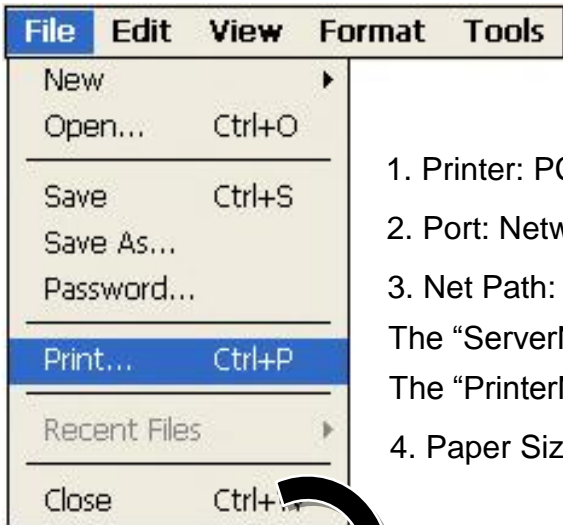

## Step 3 Set up the printer

1. Printer: PCL Laser
2. Port: Network
3. Net Path: \\ServerName\PrinterName  
The "ServerName" is the name or IP of the PC.  
The "PrinterName" is the name of share printer of the PC.
4. Paper Size: Select the paper size



**Test !!!**

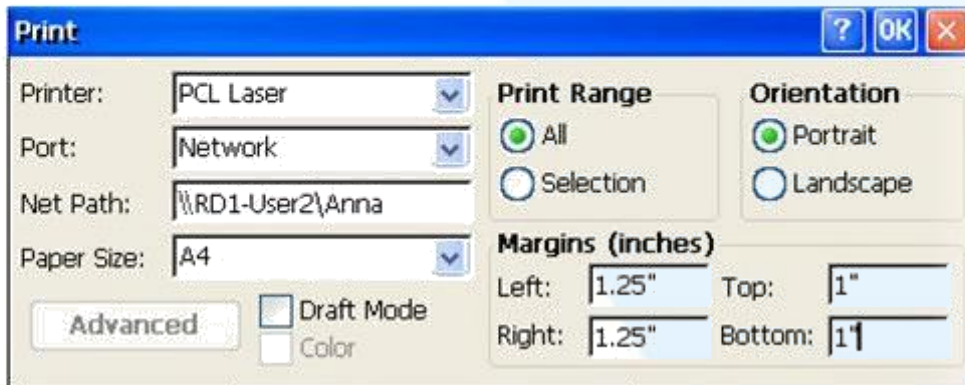

## B.1.2. How to use the USB printer

Here are step by step instructions on how to use a shared printer.

### Step 1 On XPAC side, open a WordPad format file

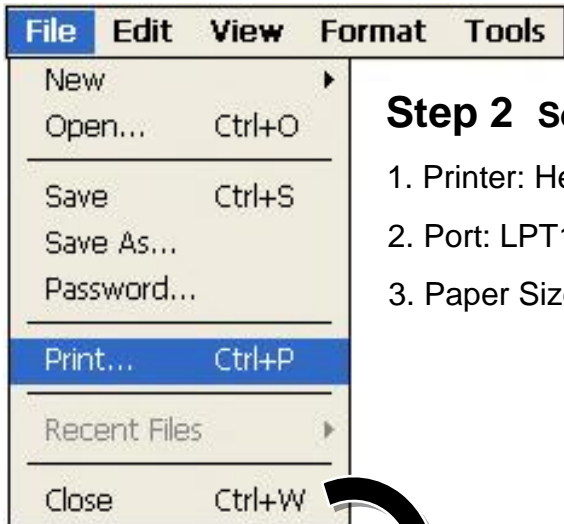

### Step 2 Set up the printer

1. Printer: Hewlett-Packard LaserJet
2. Port: LPT1
3. Paper Size: Select the paper size

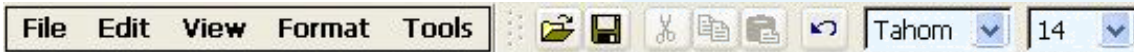

**Test !!!**

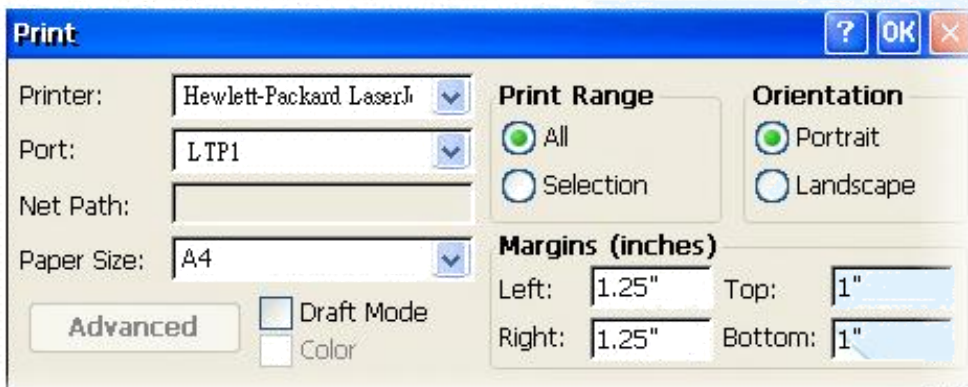



## B.2. How to Online Debug the XP-8000-Atom-CE6

Debug XP-8000-ATOM-CE6 programs in Visual Studio 2005/2008

### Step 1 Make sure the following file are listed with the matching version numbers

Path	File
C:\Program Files\Common Files\Microsoft Shared\CoreCon\1.0\Bin	1. ActiveSyncBootstrap.dll 2. ConMan2.dll 3. ConManPS.dll 4. DesktopDMA.dll 5. eDbgTL.dll 6. TcpConnectionC.dll
C:\Program Files\Common Files\Microsoft Shared\CoreCon\1.0\Bin\1033	conmanui.dll
C:\Program Files\Common Files\Microsoft Shared\CoreCon\1.0\Target\wce400\X86	1. Device Agent Transport.dll 2. eDbgTL.dll 3. TcpConnectionA.dll 4. clientshutdown.exe 5. CMAccept.exe 6. ConmanClient2.exe

**Step 2** If the version matches correctly and the entire file are there, copy the following files to XP-8000-ATOM-CE6 :\System\_Disk\ICPDAS\System folder

- Clientsshutdown.exe
- ConmanClient2.exe
- CMaccept.exe
- eDbgTL.dll
- TcpConnectionA.dll

**Step 3** On the “Tools” menu, click “Options...” command

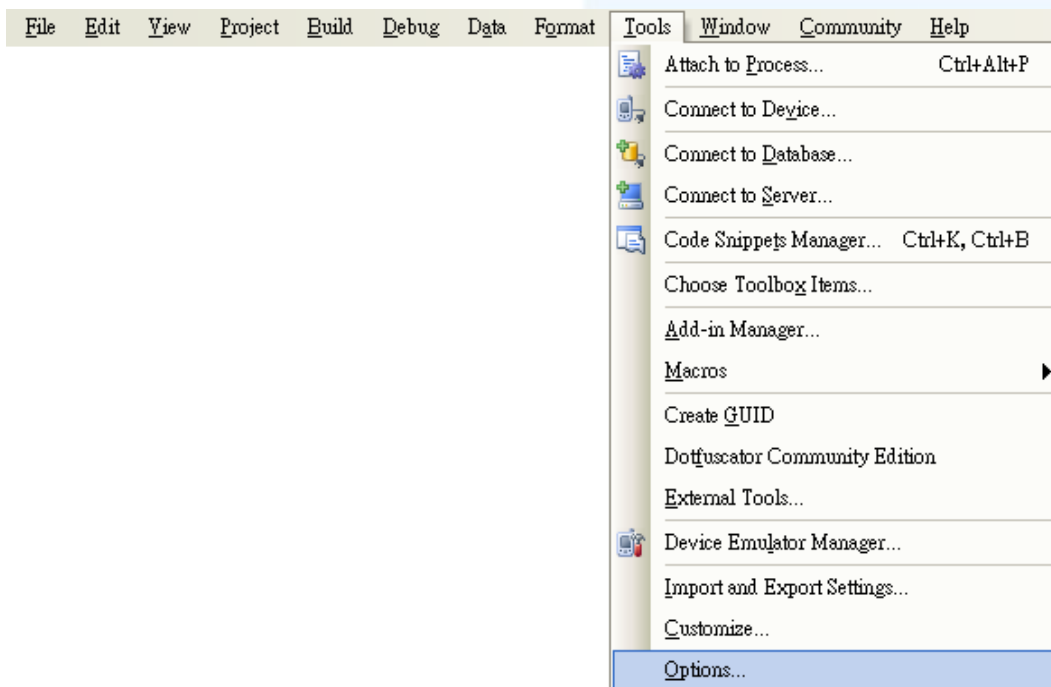

**Step 4** On the “Options” dialog, select “XPacSDK\_CE” from the “Show devices platform” list, and then click the “Properties...” button

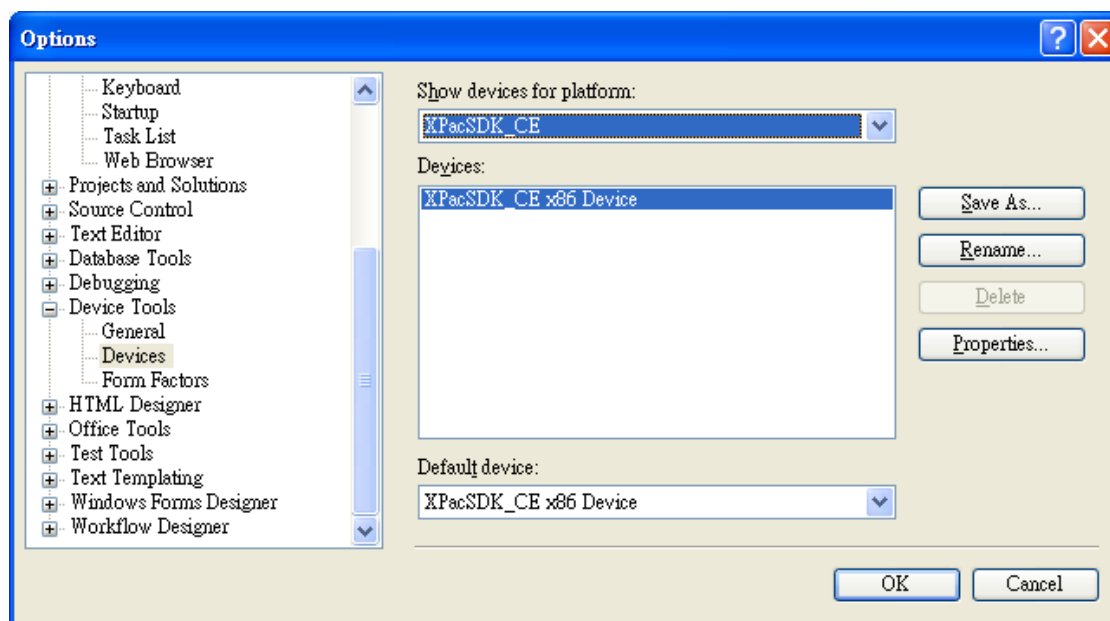

**Step 5** On the “XPacSDK\_CE x86 Device Properties” dialog, click the “Configure...” button

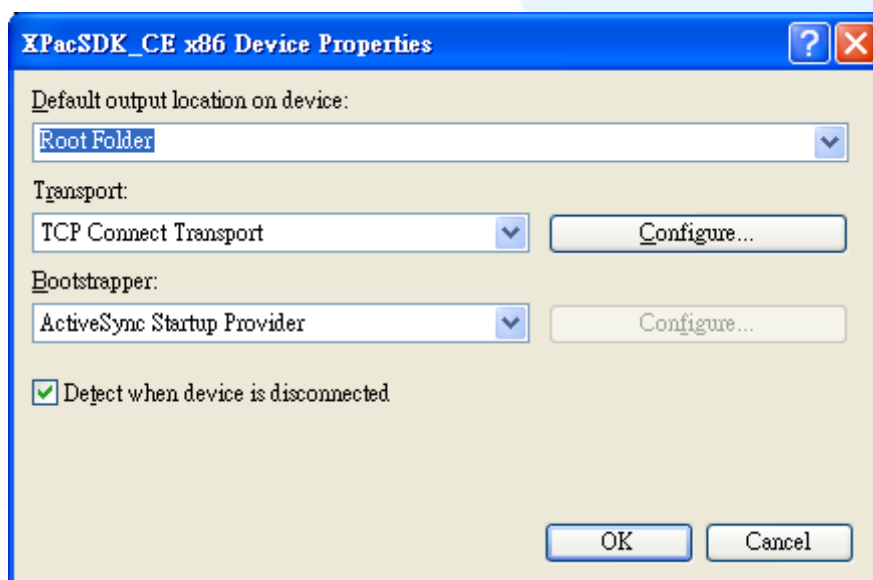

**Step 6** On the “Configure TCP/IP Transport” dialog, select the “Use specific IP address” option and type the IP address of XP-8X4X-CE6, and then click the “OK” button

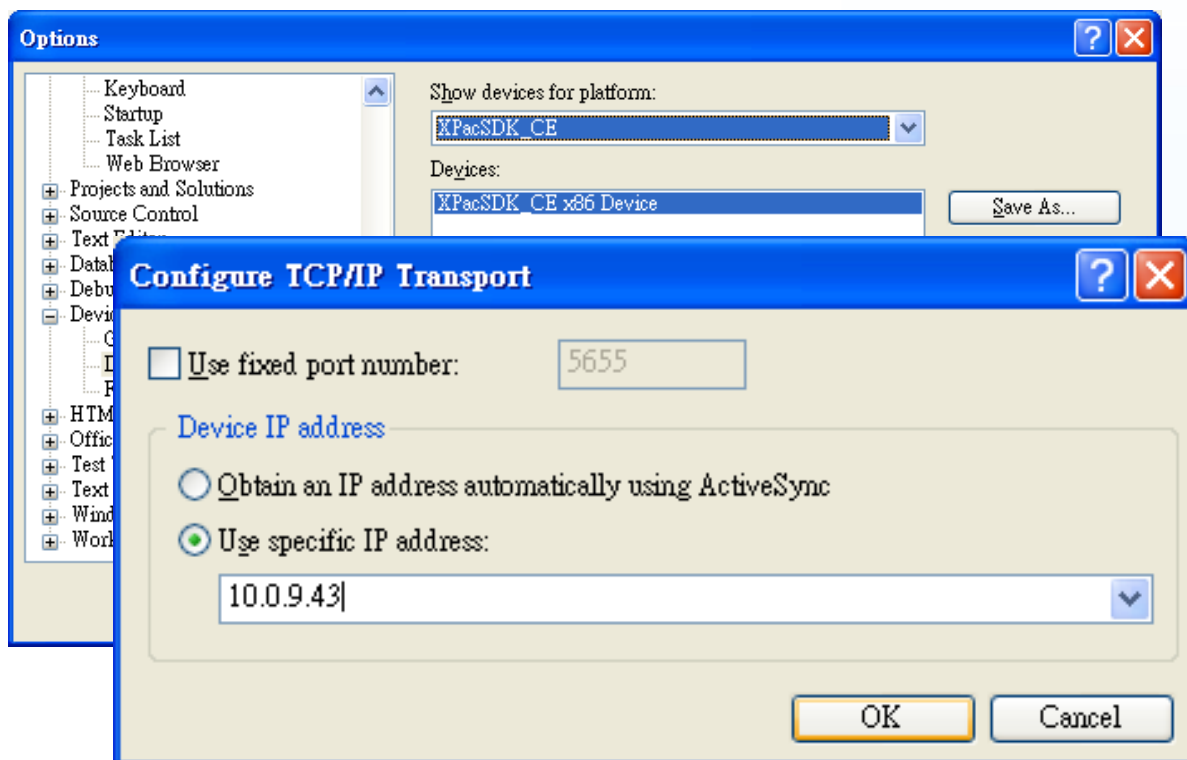

**Step 7** On the “XPacSDK\_CE x86 Device Properties” dialog, click the “OK” button

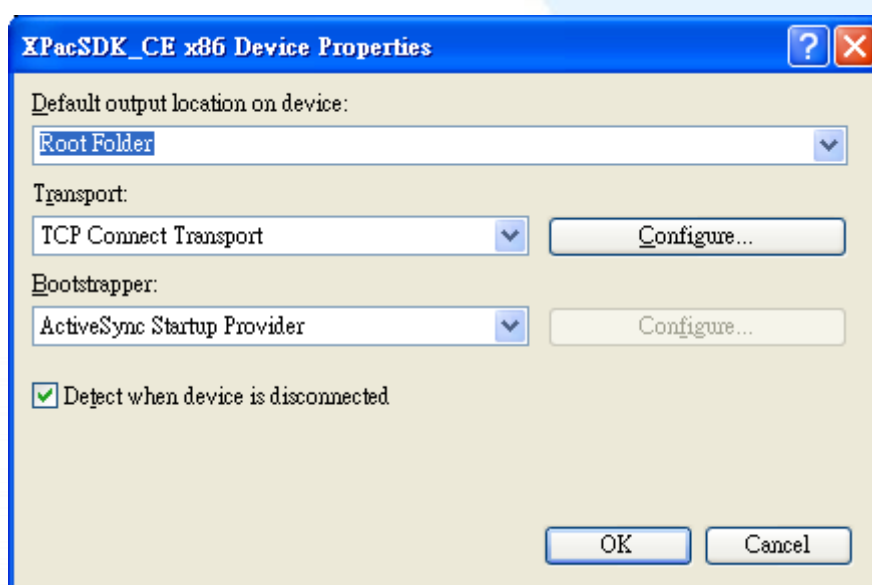

**Step 8** On the “Options” dialog, click the “OK” button

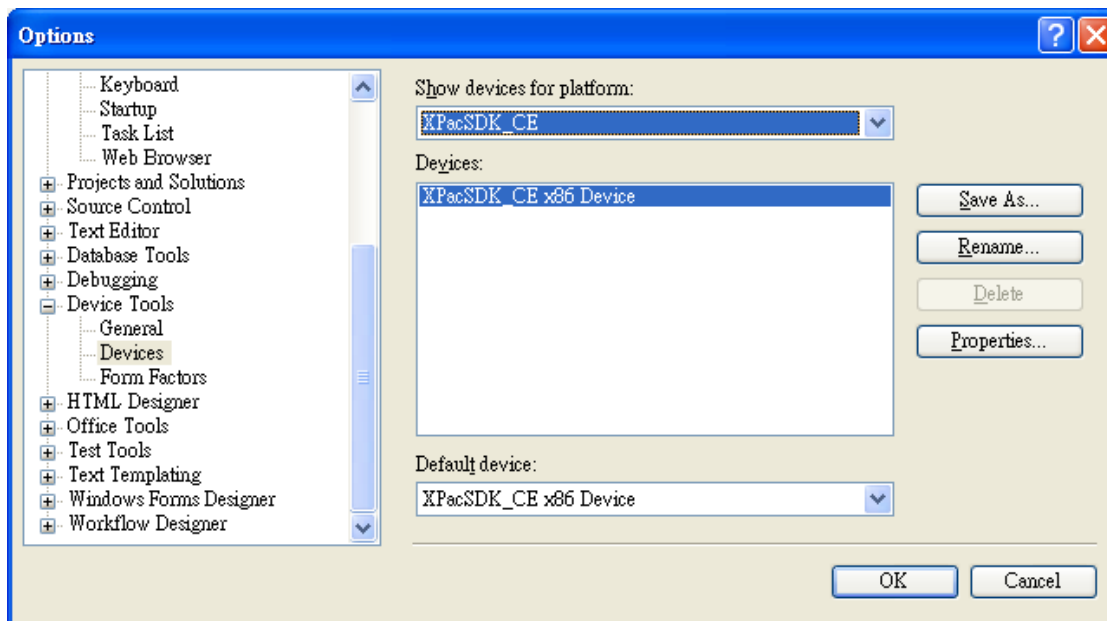

**Step 9** On the XP-8000-ATOM-CE6 controller side, run the “ConmanClient2” and the “CMAccept.exe” applications which is located at: \System\_Disk\ICPDAS\System

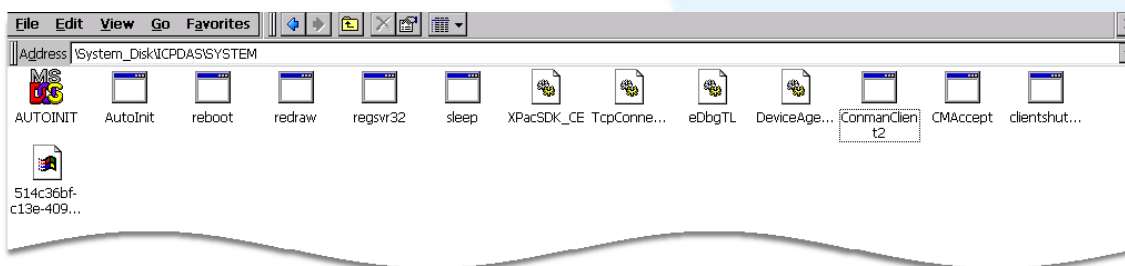

## Step 10 On the “Tools” menu, click “Connect to Device...” command

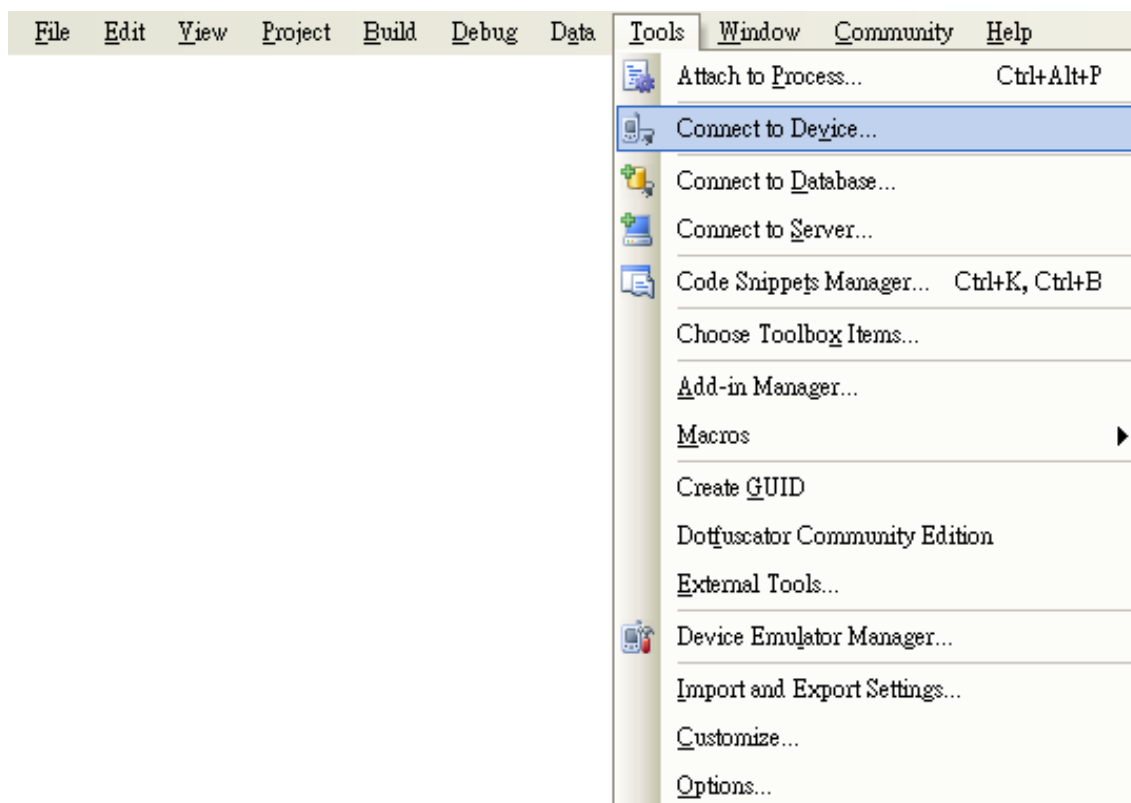

## Step 11 On the “Connect to Device” dialog, select “XPacSDK\_CE” from “Platform” list and then click the “Connect” button

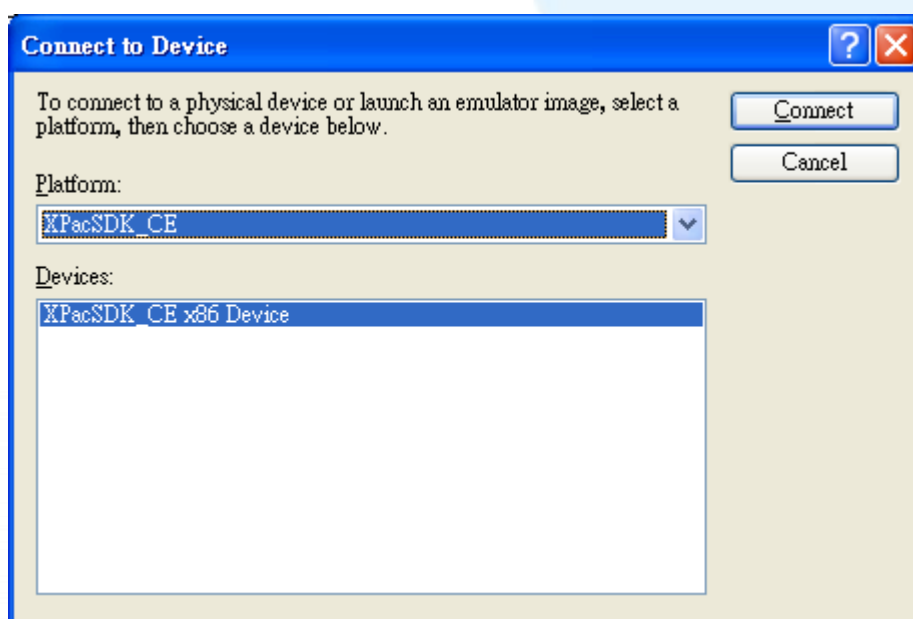

**Step 12** On the “Tools” menu, click “Connect to Device...” command

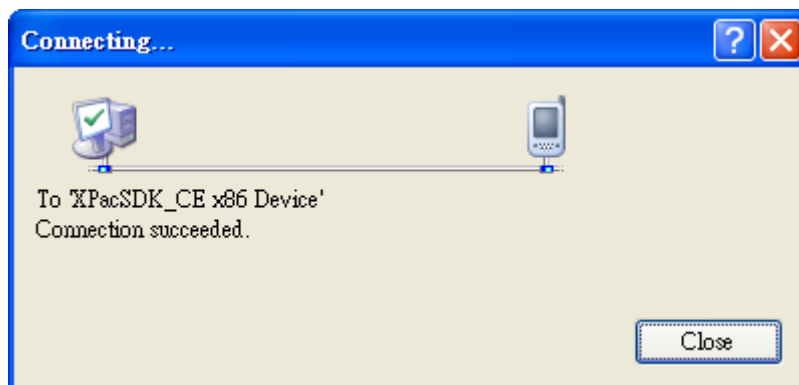

**Step 13** Connection established. Then you can debug on line

## FAQ

---

If the connection fails shown as follow, return to step 11 to do the action below

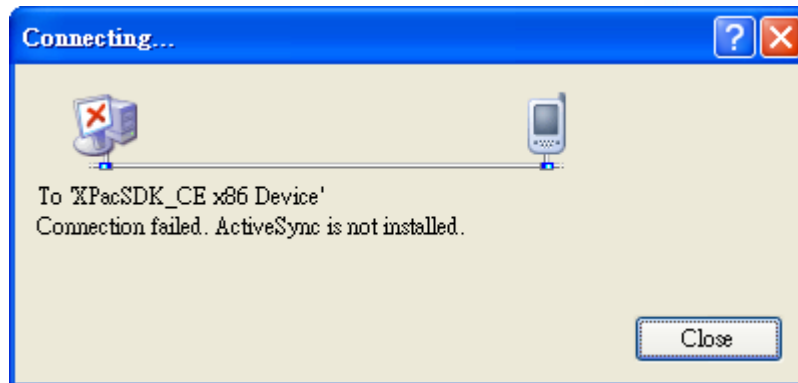

Open the command prompt, run the  
“ConmanClient2.exe/transport:tcpconnectiona.dll/property:port=5000/id:Con” at:  
\\System\_Disk\ICPDAS\System, and then run the “CMAccept.exe”

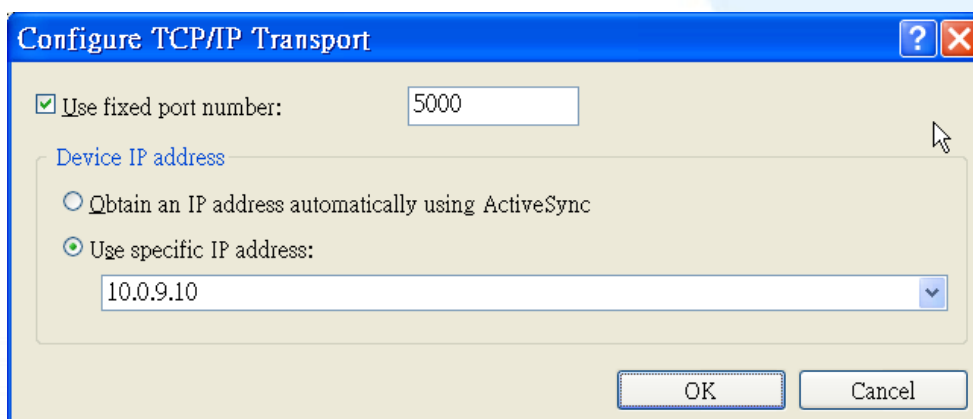



## B.3. How to automatically synchronize the XPAC clock with an Internet Time Server

Here are step by step instructions on how to automatically synchronize the XPAC clock with an Internet Time Server.

### Step 1 Run the XPAC Utility



### Step 2 On the General tab, press Configure button

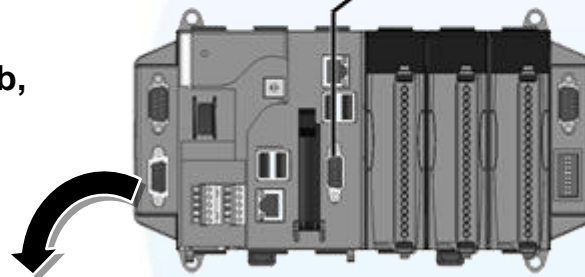

**Step 3** Select the domain name in the Server drop down list, and then enter a value in the Autoupdate Frequency field

**Step 4** Check the Automatically synchronize with an internet time server check box

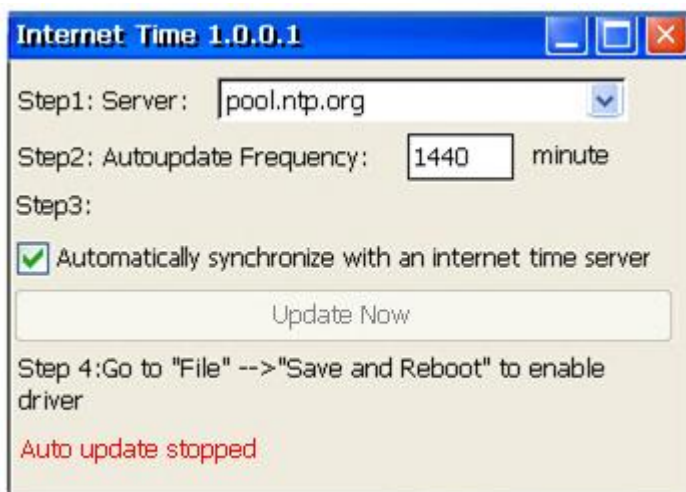

**Step 5** On the File menu, click Save and Reboot

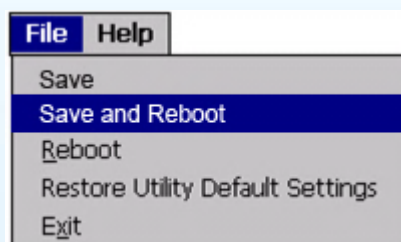

**Step 6** The XPAC will automatically synchronize with an internet time server regularly

**Step 7** Press Update Now to synchronize XPAC clock immediately

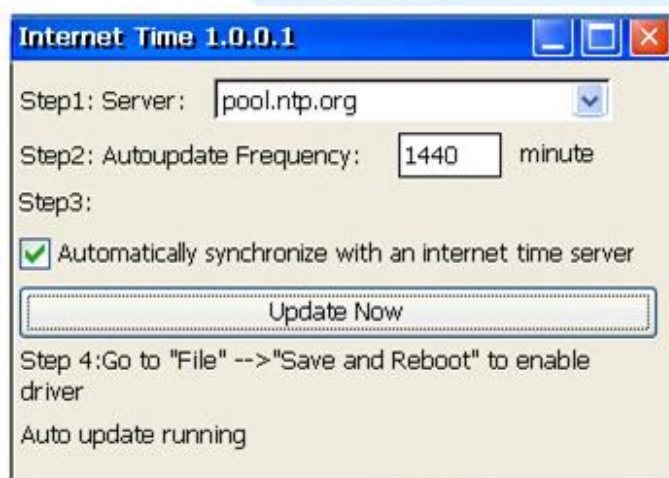

## **B.4. How to add a user account to remote login the XPAC from PC**

## B.4.1. How to add a user account

Here are step by step instructions on how to add a user account.

### Step 1 Run the XPAC Utility

### Step 2 On the Network tab, click Login tab, type the User Name and Password, and then click Add button



**XPAC Utility [1.0.2.8]**

File Help

General Display IP Config Network Device Information Auto Execution Rotary Execution M

Access Login

User name Password

Anna \*\*\*\*\* Add Delete

User name	Password

**Step 3** The user has been added to the allowed under the remote login and included in the following list

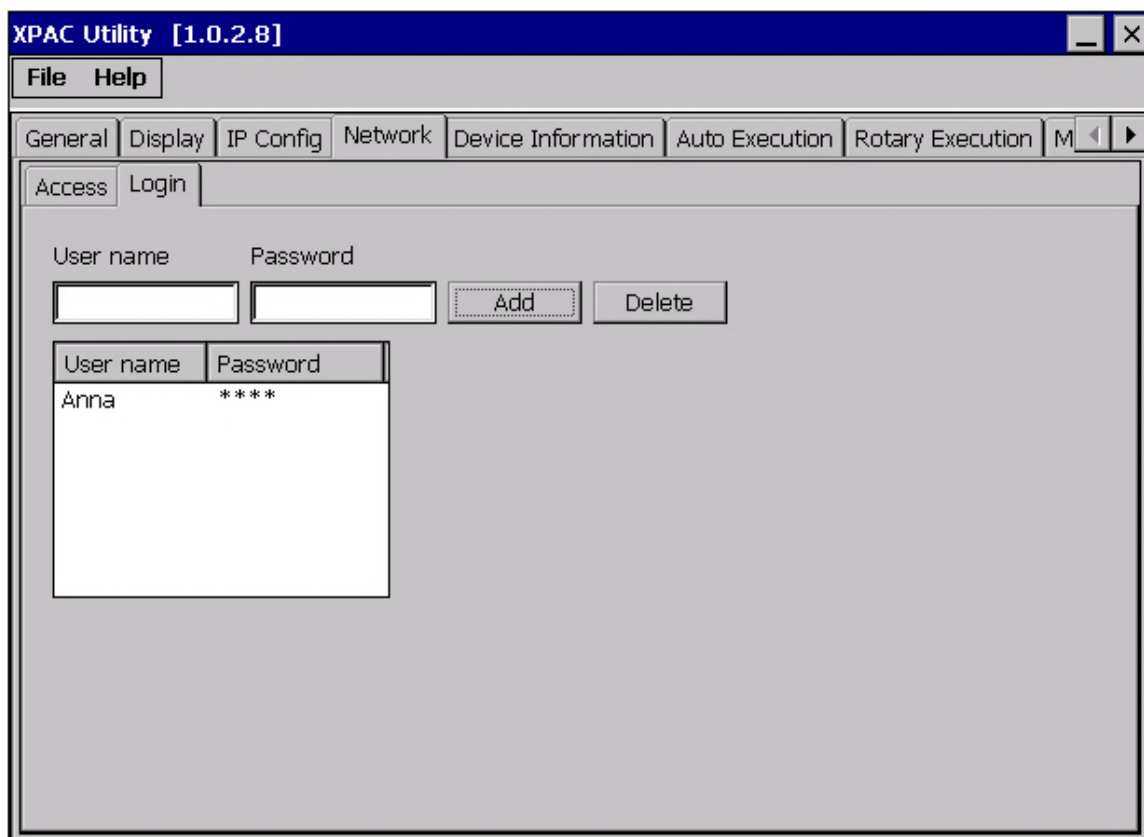

**Step 4** On the File menu, click Save and Reboot for changes to take effect

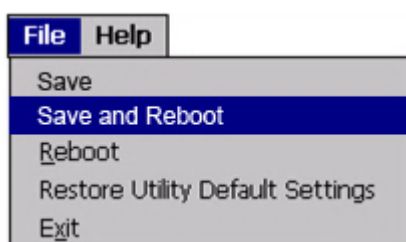

## B.4.2. How to Use telnet to remote login the XPAC from PC

Here are step by step instructions on how to use telnet to remote login the XPAC from PC.

### Step 1 On the PC, open a MS-DOS command prompt

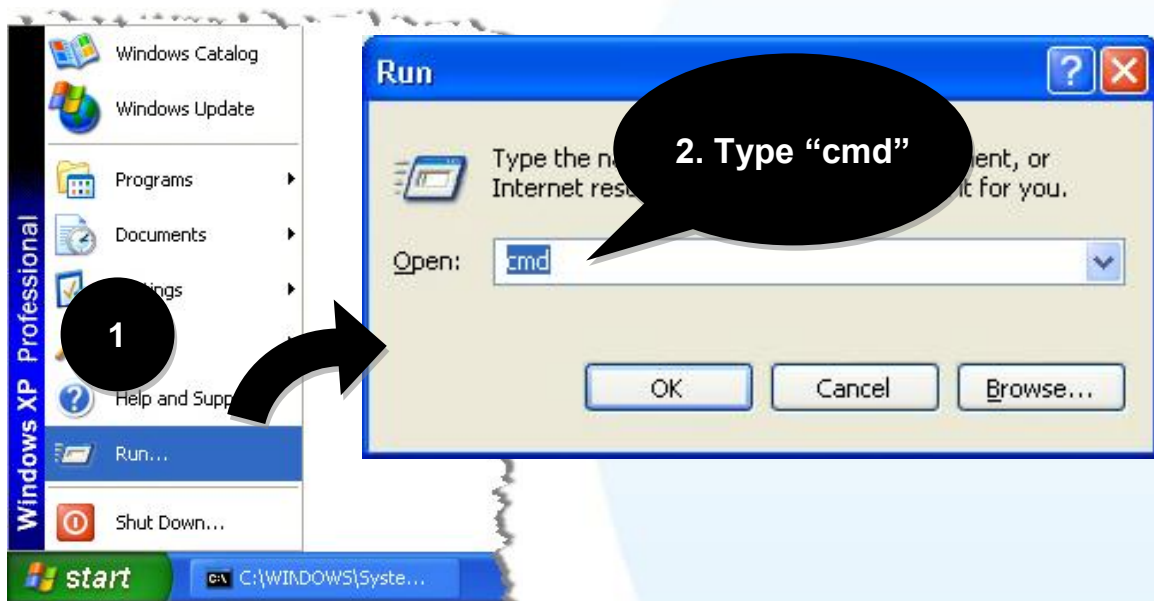

### Step 2 At the command prompt, type "telnet (IP address)"



**Step 3** The connection has been set up, and then type the name and password

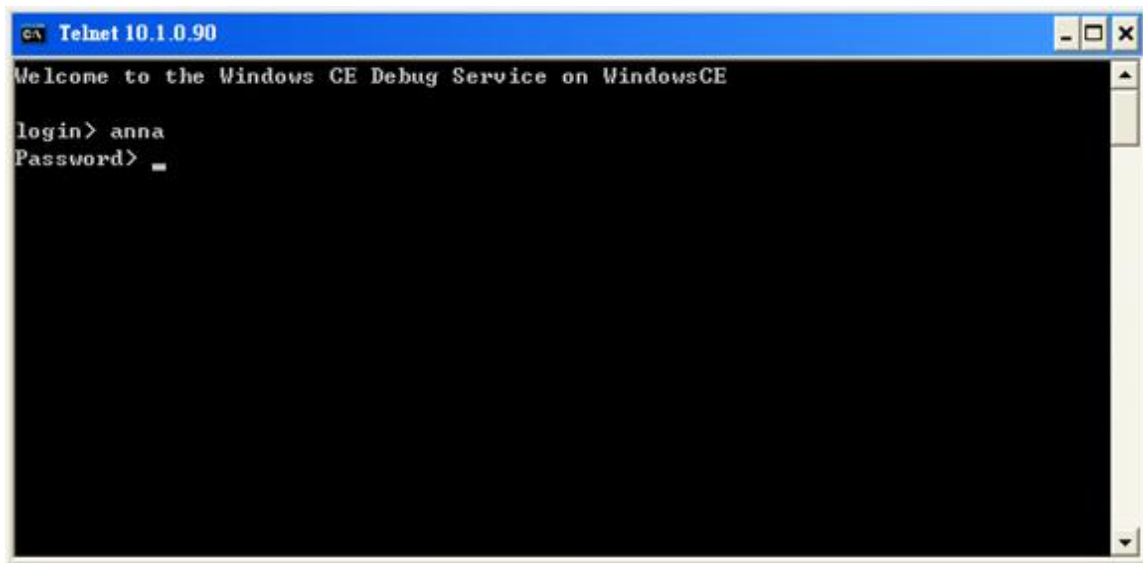

```

c:\ Telnet 10.1.0.90
Welcome to the Windows CE Debug Service on WindowsCE

login> anna
Password> _

```

**Step 4** The remote login has been completed

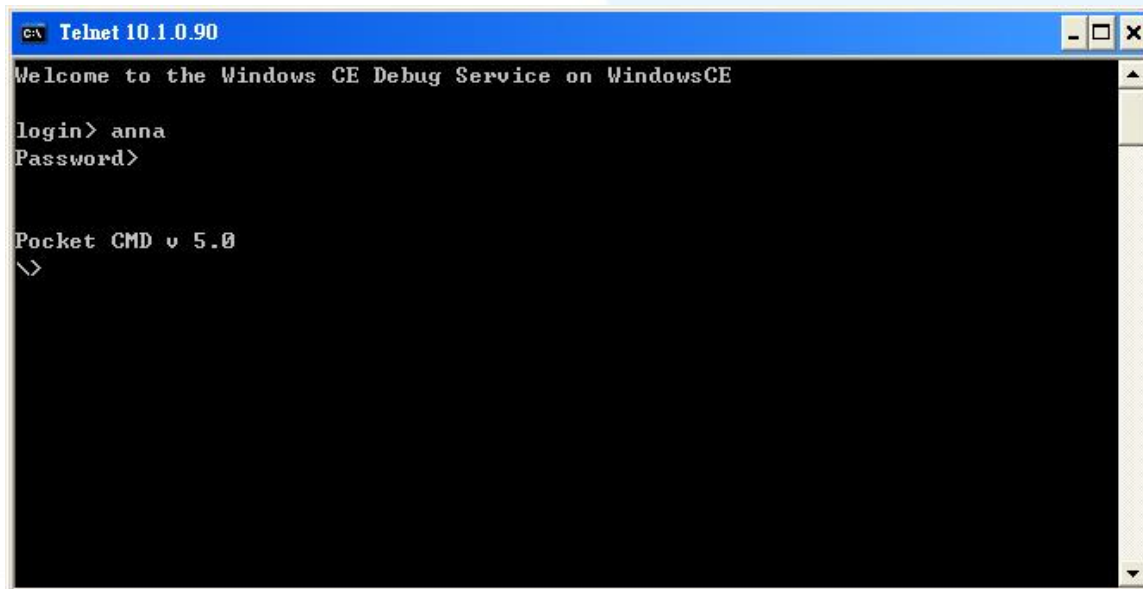

```

c:\ Telnet 10.1.0.90
Welcome to the Windows CE Debug Service on WindowsCE

login> anna
Password>

Pocket CMD v 5.0
\>

```

## B.4.3. How to remove the user from the login list

Here are step by step instructions on how to remote the user from the login list.

**Step 1** Click a user from the list which you want to remove, and the user will display in the field, and then press Delete to delete the user from the login list

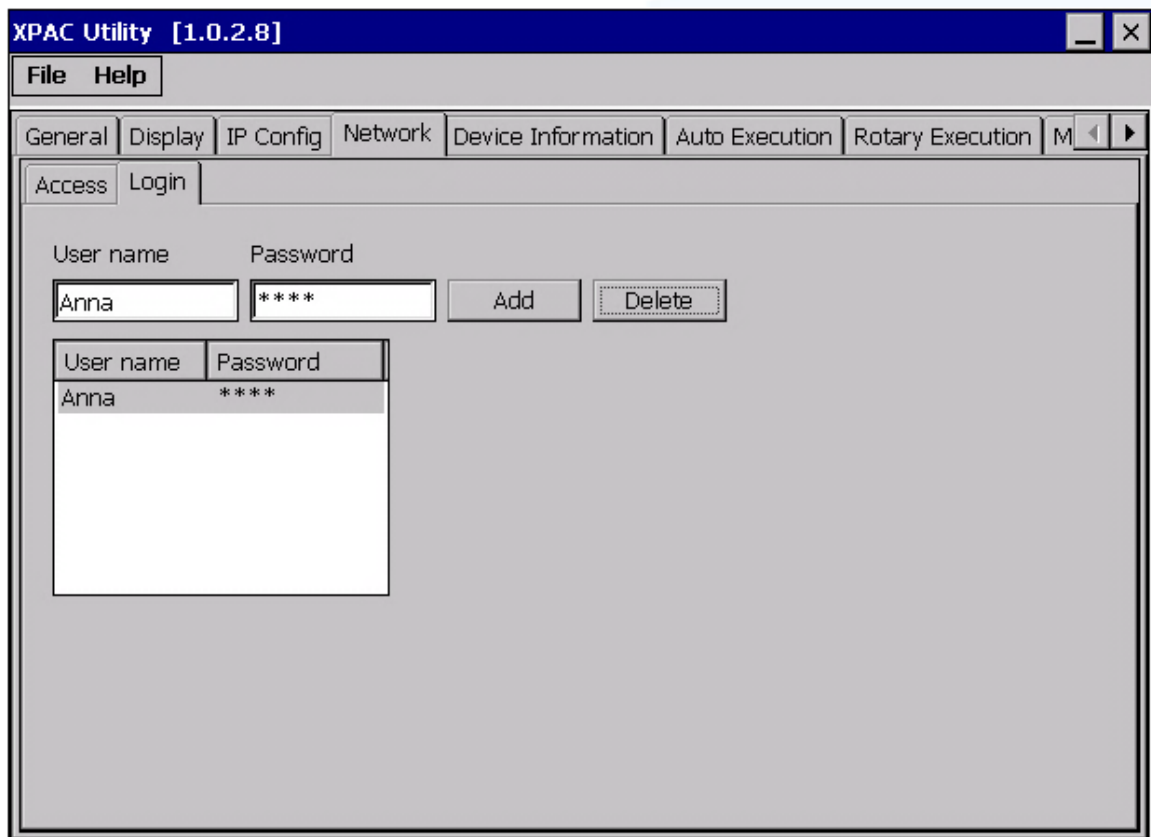

**Step 2** On the File menu, click Save and Reboot for changes to take effect

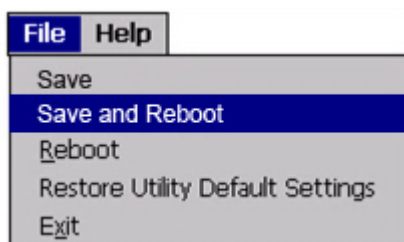



## **B.5. How to use XPacSDK to program the XP-8000-Atom-CE6**

## B.5.1. How to Read the XPAC Mode with XPacSDK

The rotary switch is used to set the operating mode.



During normal operation, the position of the rotary switch has no effects on XP-8000-ATOM-CE6.

You can use XPacSDK to read back the value of the rotary switch.

```
int pac_GetRotaryID();
```

The returning value of `pac_GetRotaryID()` is what the arrow points to.

## B.5.2. How to Read the Module ID with XPAC API

The DIP switch can be used to set the Module ID to a number from 0 to 255. Do not use Module ID 0 for communication.

During normal operation, the positions of the DIP switches have no effects on XP-8000-ATOM-CE6.

You can use XPacSDK to read back the value of the DIP switches.

```
int pac_GetDIPSwitch();
```

Below is the figure of DIP switches similar to that of XP-8000-ATOM-CE6.

The first DIP switch is the LSB and the 8th DIP switch is the MSB.

If the DIP switch slides up to the “ON” side, it represents 1.

If the DIP switch slides down to the number side, it represents 0.

In this way, the eight-bit DIP switches can be represented by 0 ~ 255.

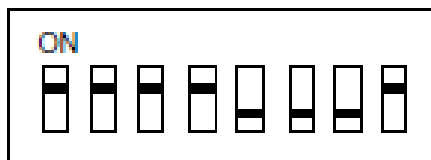

## B.5.3. How to Use the Multi-IO Module with XPAC API

The Multi-IO Modules tab provides function to check the driver of multi-IO modules, such as 8114, 8144, 8142, and 8112.

For more information about expansion RS-232/RS-422/RS-485 communication module that are compatible with the XP-8000-Atom-CE6, please refer to

[http://www.icpdas.com/products/Remote\\_IO/i-8ke/selection\\_rs232\\_i8k.htm](http://www.icpdas.com/products/Remote_IO/i-8ke/selection_rs232_i8k.htm)

**Step 1** Insert the multi-IO module into XP-8000-ATOM-CE6

**Step 2** Run the XPAC Utility

**Step 3** On the Multi-IO Modules tab, check the driver of the I/O modules

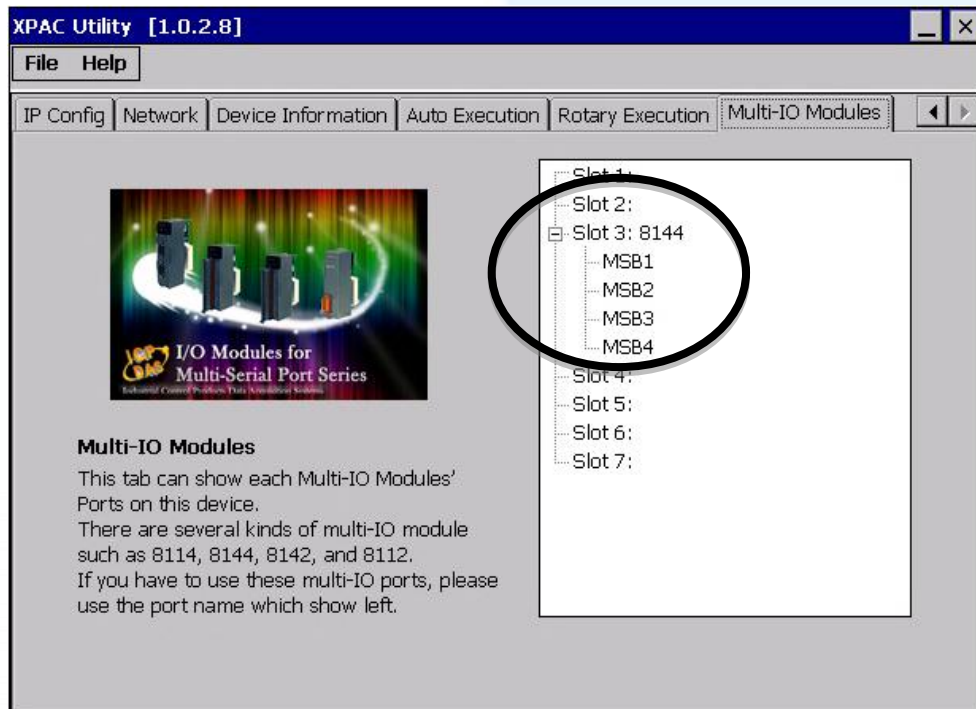
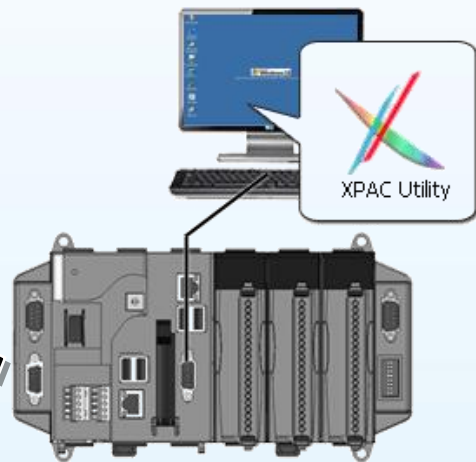

## Step 4 Program the multi-IO module

Opening 8144 in Slot 1

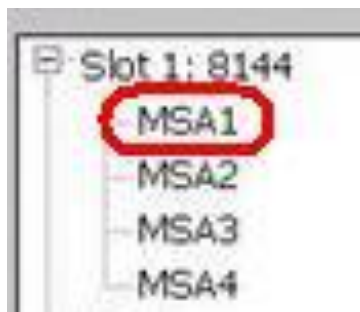

### Code Snippets

---

```
{  
  BOOL ret;  
  HANDLE hOpen;  
  char buf[4096];  
  
  hOpen = uart_Open("MSA1");  
  ret = uart_SendCmd(hOpen,"$01M", buf);  
  uart_Close(hPort);  
}
```

---

For more information about expansion RS-232/RS-422/RS-485 communication module that are compatible with the XP-8000-ATOM-CE6, please refer to [http://www.icpdas.com/products/Remote IO/i-8ke/selection\\_rs232\\_i8k.htm](http://www.icpdas.com/products/Remote_IO/i-8ke/selection_rs232_i8k.htm)

## B.6. How to update software from XP-8000-CE6 to XP-8000-Atom-CE

The CPU type of XP-8000-CE6 and XP-8000-Atom-CE6 is x86-based and the OS is also Windows CE6.0, so all software are compatible. All old programs and applications on XP-8000-CE6 can run smoothly on XP-8000-Atom-CE6 without any modification and re-compiling. Upgrading applications only just copy and play from XP-8000-CE6 to XP-8000-Atom-CE6.

The software compatibility is listed as following:

### Software compatibility with XP-8000-CE6 (LX800)

Compatibility Comparison		O: Compatible, X: Incompatible
Items	Compatibility	
OS image	X	
Rescue Disk	X	
VC/C#/VB.net programs	O	
XPacSDK_CE6 SDK	O (Since V2.0.0.5 and later)	
All DCON 8K series library	O	
XPAC utility	O (Since V1.0.2.7 and later)	
NAPOPC_CE6	O	
Tools on System_Disk	O	

Compatibility Comparison		O: Work, X: Doesn't Work	
API Functions	XP-8000-CE6	XP-8000-Atom-CE6	
pac_EnableLED	X	O	
The others	O	O	

Note: The version of XPacSDK\_CE6 must be V2.0.0.5 or later

## Appendix C. Revision History

This chapter provides revision history information to this document.

The table below shows the revision history.

<b>Revision</b>	<b>Date</b>	<b>Description</b>
1.0.1	June 2011	Initial issue