

EtherCAT



## ECAT-2045/ECAT-2057/ ECAT-2057P/ECAT-2057-NPN

EtherCAT Slave I/O Module with Isolated 16-ch Digital Outputs

### Features

- On the fly processing: EtherCAT
- Powerful MCU handles efficient network traffic
- 2 x RJ-45 bus interface
- Distance between stations up to 100 m (100 BASE-TX)
- Support daisy chain connection
- EtherCAT conformance test tool verified
- Removable terminal block connector
- LED indicators for the output status
- Built-In isolated 16-ch digital outputs
- RoHS compliant
- ESD Protection 4 KV Contact for each channel



### Introduction

The ECAT-2045 is an industrial slave I/O module built in 16 digital outputs. It is equipped with the EtherCAT\* protocol and installed by daisy chain connection that provides a more scalable system with fewer wires. Users can obtain the input and output status not only via the process data but also from its LED indicators. The ECAT-2045 has passed and verified by the conformance test tool, therefore eligible EtherCAT Master or configurator can manipulate it simply and implement your various applications easily.

\* EtherCAT® is registered trademark and patented technology, licensed by Beckhoff Automation GmbH, Germany.

### Hardware Specifications

Model	ECAT-2045	ECAT-2057	ECAT-2057P	ECAT-2057-NPN
<b>Digital Output</b>				
Channels	16			
Output Type	Open Collector (Sink)	Open Emmitter (Source)		Open Collector (Sink)
Load Voltage	+3.5 ~ +50 V	+3.5 ~ +30 V	+10 ~ 40 V	+3.5 ~ +30 V
Max. Load Current	700 mA per channel	100 mA per channel	500mA per channel	100 mA per channel
Isolation Voltage	3750 V <sub>rms</sub>			
<b>Communication Interface</b>				
Connector	2 x RJ-45			
Protocol	EtherCAT			
Distance between Stations	Max. 100 m (100 BASE-TX)			
Data Transfer Medium	Ethernet/EtherCAT Cable (Min. CAT 5), Shielded			
<b>EMS Protection</b>				
ESD (IEC 61000-4-2)	±4 kV Contact for Each Terminal			
EFT (IEC 61000-4-4)	Signal: 1 KV Class A; Power: 1 KV Class A			
Surge (IEC 61000-4-5)	1 KV Class A			
<b>Power</b>				
Input Voltage Range	+10 ~ +30 Vdc			
Power Consumption	4 W Max.			
<b>Mechanical</b>				
Dimensions (H x W x D)	110 mm x 90 mm x 33 mm			
Installation	DIN-Rail Mounting			
Case Material	UL 94V-0 Housing			
<b>Environment</b>				
Operating Temperature	-25 ~ +75°C			
Storage Temperature	-30 ~ +80°C			
Relative Humidity	10 ~ 90% RH, Non-condensing			

## Applications

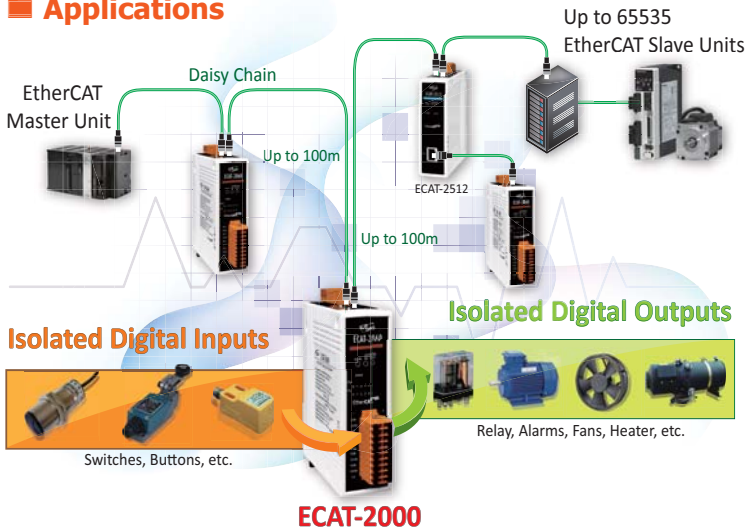

## Pin Assignments

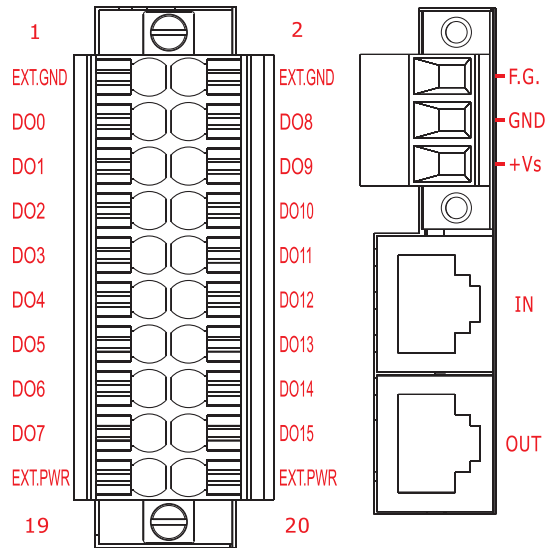

## Wire Connections

ECAT-2045 / ECAT-2057-PNP		
Output Type	ON State Readback as 1	OFF State Readback as 0
Drive Relay		
Resistance Load		

ECAT-2057/ECAT-2057P		
Output Type	ON State Readback as 1	OFF State Readback as 0
Drive Relay		
Resistance Load		

## Dimensions (Units: mm)

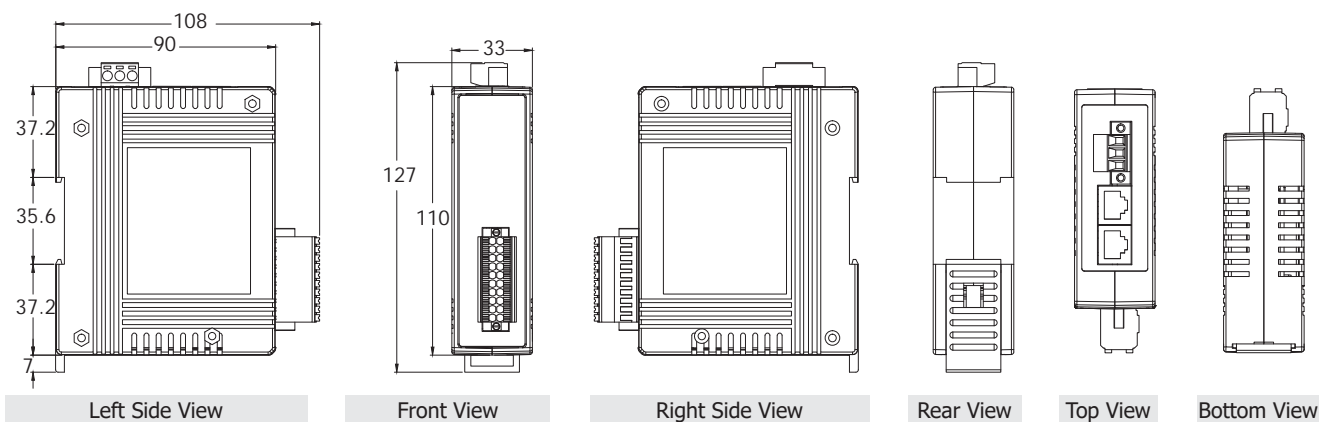

## Ordering Information

<b>ECAT-2045 CR</b>	EtherCAT Slave I/O Module with Isolated 16-ch Digital Outputs (RoHS)
<b>ECAT-2057 CR</b>	EtherCAT Slave I/O Module with Isolated 16-ch Source-type Digital Outputs (RoHS)
<b>ECAT-2057P CR</b>	EtherCAT Slave I/O Module with Isolated 16-ch Source-type Digital Outputs (500mA) (RoHS)
<b>ECAT-2057-NPN CR</b>	EtherCAT Slave I/O Module with Isolated 16-ch Digital Outputs (RoHS)