

HART 解決方案

- XP-8xx7-CE6
- WP-8xx7
- VP-2xW7

- 支援 I-87H17W 模組來與其他 HART 設備通訊 ([FAQ-136](#))

泓格科技 ISaGRAF PAC 之 HART 解決方案

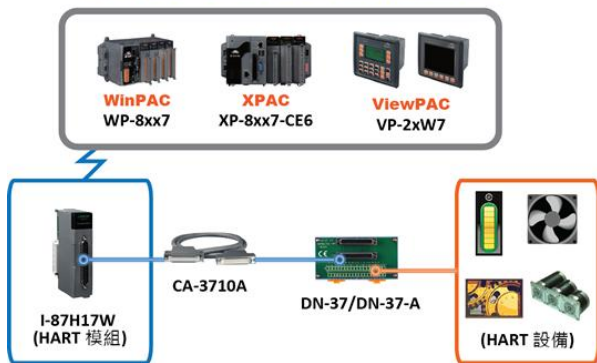

資料庫應用

- XP-8xx7-CE6
- WP-8xx7
- VP-2xW7

- 支援 SQL Client 功能 ([FAQ-135](#))

泓格科技 WinCE PAC 支援 SQL Server 通訊應用



運動控制: 採用 I-8094F/8092F/8094

- XP-8xx7-CE6
- WP-8xx7
- VP-2xW7

- 一套 ISaGRAF 軟體可實現 HMI 畫面設計, I/O 控制與運動控制 ([FAQ-132](#))



Soft-GRAF 軟體: 建立多采多姿的 HMI 畫面

- XP-8xx7-CE6
- WP-8xx7
- VP-2xW7

- 使用一套 ISaGRAF 軟體, 即可完成 控制邏輯 與 HMI 畫面設計 ([FAQ-131](#))



連接 PM-2133/2134 智能電表

- XP-8xx7-CE6
- WP-8xx7
- VP-2xW7

- 可應用於中小型賣場、建築之各樓層與工廠中負載機具等之電力量測監控系統 ([FAQ-129](#))

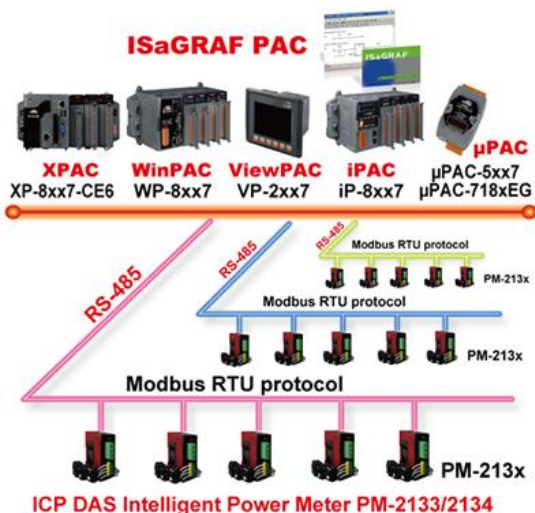

水泥建築物的應力量測應用

- XP-8xx7-CE6
- WP-8xx7
- VP-2xW7

- 包括振弦式傳感器(VW sensor) 與 差阻式傳感器(Carlson Strain Gauge Inputs) 解決方案, 主要應用來量測建築物的應力 或 內部滲水的壓力, 可用於如江河大壩的監控, 橋樑監控 ...等 ([FAQ-091, 128](#))

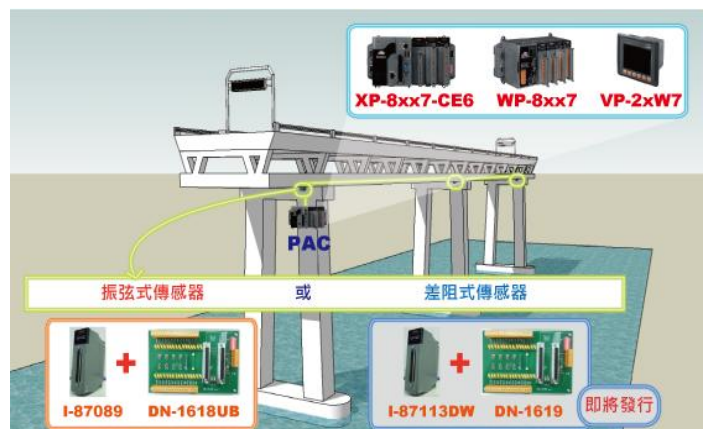

eLogger HMI 人機介面應用

- XP-8xx7-CE6
- WP-8xx7
- VP-2xW7

- 泓格科技免費提供給產品使用者的 HMI 多功能人機介面開發工具, 用以設計人機介面的圖形與控制元件等項目 (FAQ-115)

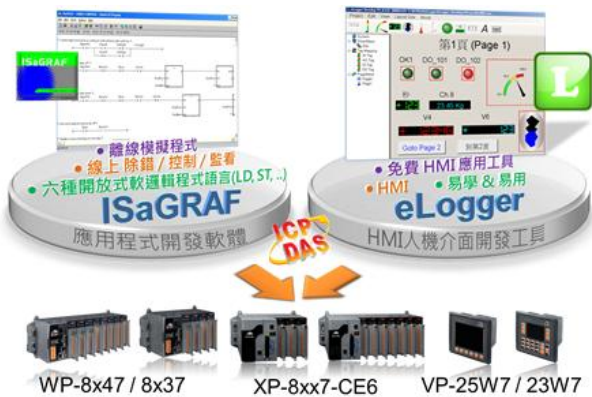

中央與地區控制站間的通訊備援 (冗餘) 系統

- XP-8xx7-CE6
- WP-8xx7
- VP-2xW7

- (FAQ-119)

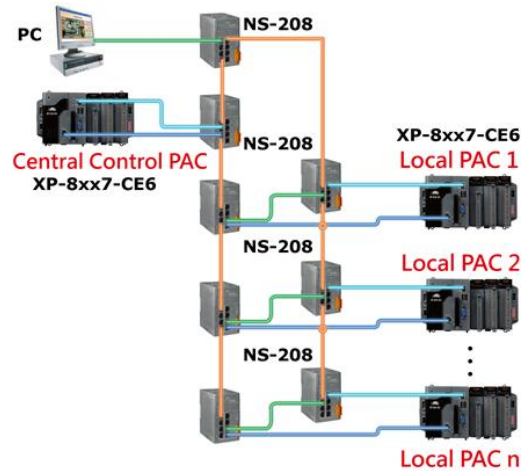

備援 (冗餘) 系統 - 搭配 iDCS-8000

- XP-8xx7-CE6
- WP-8xx7
- VP-2xW7

- 雙 PAC, 雙網口備援系統 (FAQ-125)

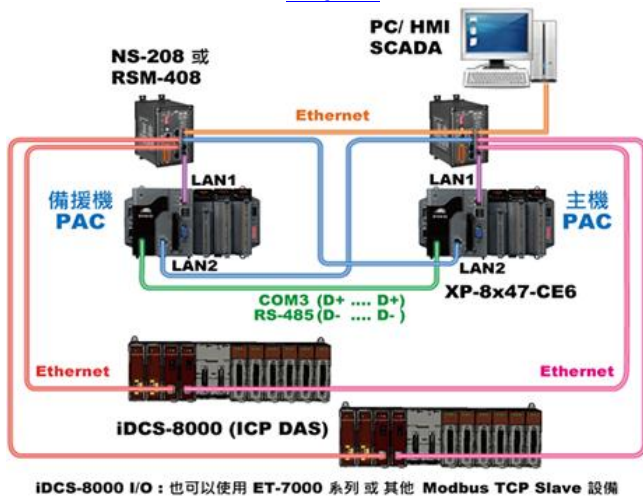

iDCS-8000 I/O : 也可以使用 ET-7000 系列 或其他 Modbus TCP Slave 設備

備援 (冗餘) 系統 - 搭配 Ethernet I/O

- XP-8xx7-CE6
- WP-8xx7
- VP-2xW7

- 掃描 Ethernet I/O 比掃描 RS-485 I-7000 或 I-87K I/O 更加快速 (FAQ-125)

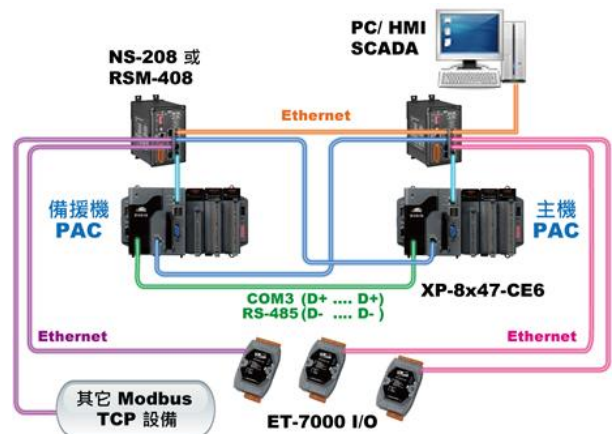

備援 (冗餘) 系統 - 搭配 RS-485 I/O

- XP-8xx7-CE6
- WP-8xx7
- VP-2xW7

- I/O 可熱插拔. (限 RU-87P1/2/4/8 搭配 I-87K 高卡 I/O) (FAQ-093, 125, 138)

WP-8x47 或 XP-8xx7-CE6 備援 (冗餘) 系統 - 搭配 RS-485 I/O

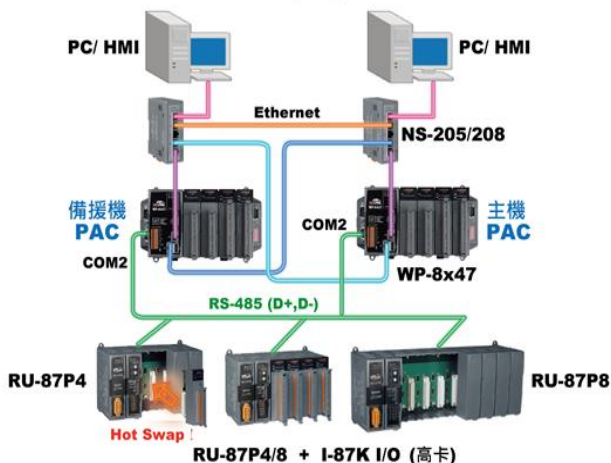

Hot Swap! RU-87P4/8 + I-87K I/O (高卡)

Modbus TCP/IP Master

- XP-8xx7-CE6
- WP-8xx7
- VP-2xW7

- 最多可以連接 100 個 Modbus TCP/IP slave 設備. 可連接各類有支持標準 Modbus TCP/IP Slave 通訊協議的設備 (FAQ-113)

Modbus TCP/IP Master 應用

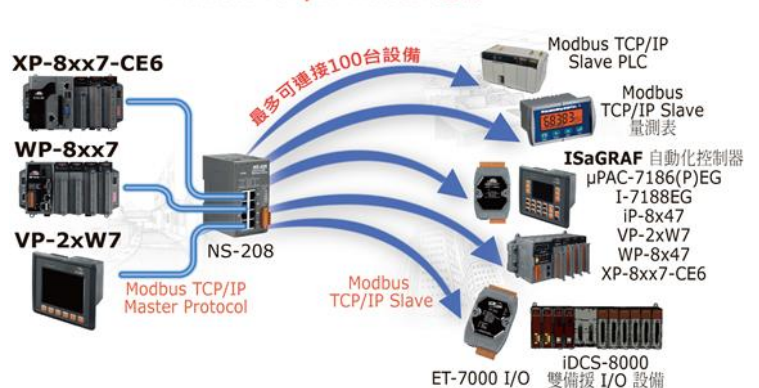

ZigBee 無線傳輸方案

- XP-8xx7-CE6
- WP-8xx7
- VP-2xW7

● 降低佈線成本並可遠距離控制 I/O 模塊或進行資料收集

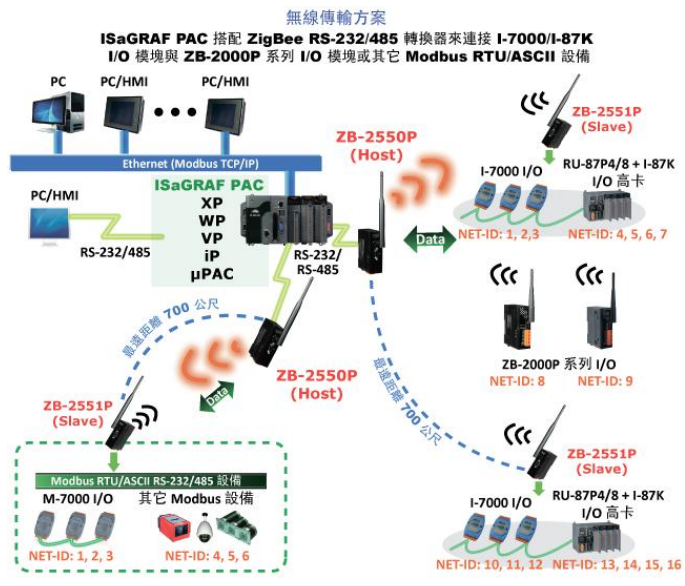

GPS 應用: ISaGRAF PAC 加上 I-87211W 或 GPS-721

- XP-8xx7-CE6
- WP-8xx7
- VP-2xW7

● 可用於 自動對時 與 取得當地的經緯度座標 (FAQ-107)

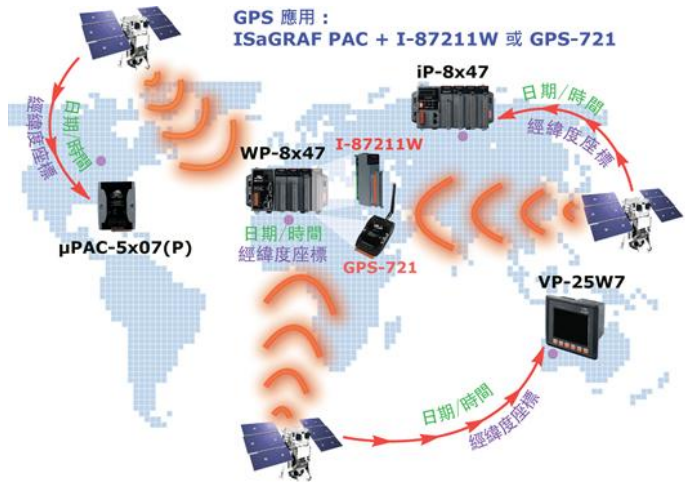

整合 CAN/CANopen 設備與傳感器

- XP-8xx7-CE6
- WP-8xx7
- VP-2xW7

● (FAQ-086)

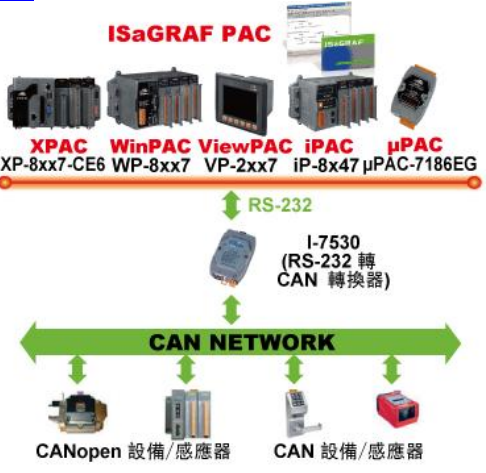

傳送郵件並夾帶一個檔案

- XP-8xx7-CE6
- WP-8xx7
- VP-2xW7

● 透過 Ethernet Port 可傳送夾帶一個附件的 Email, 附件最大容量約 488K bytes, 一次可傳送給 10 位收件者 (FAQ-067, 077)

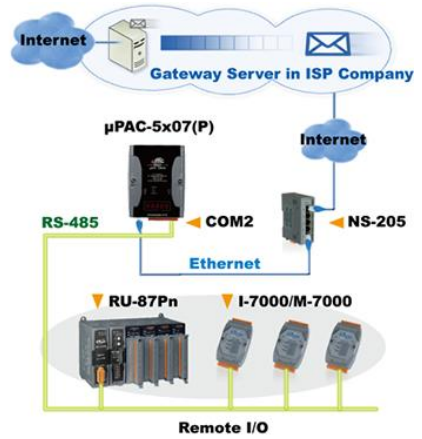

FRnet 快速分散式 I/O 程式

- XP-8xx7-CE6
- WP-8xx7
- VP-2xW7

● (FAQ-082)

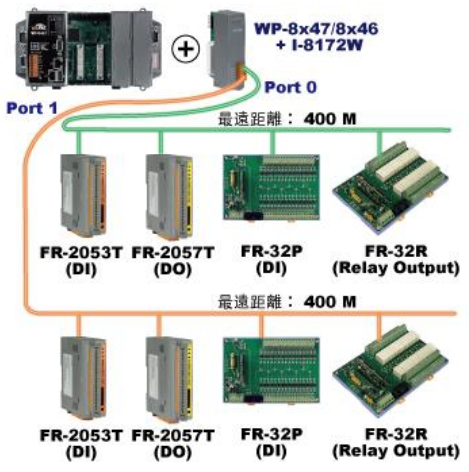

主動訊號採集與資料回報系統

- XP-8xx7-CE6
- WP-8xx7
- VP-2xW7

● 優點: 不同區域的控制器, 不需申請固定的 Internet IP (FAQ-065)

穩定且具成本效益的主動資料採集與回報系統

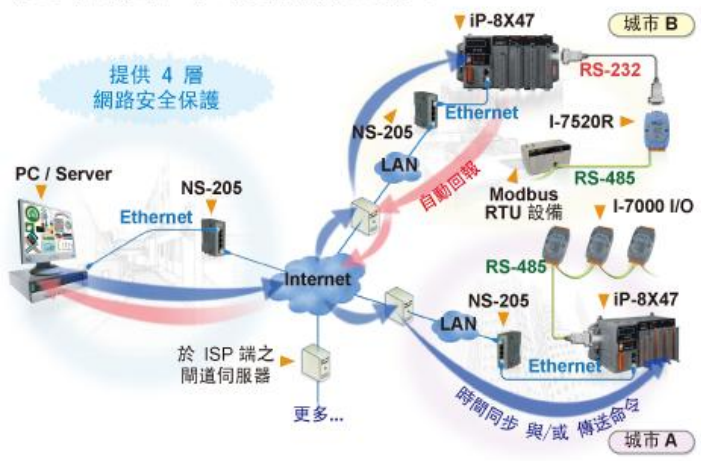

Modbus RTU/TCP Slave 埠

- | | | |
|---|---|---|
| <input checked="" type="checkbox"/> XP-8xx7-CE6 | <input checked="" type="checkbox"/> WP-8xx7 | <input checked="" type="checkbox"/> VP-2xW7 |
|---|---|---|

- Modbus RTU (RS-232/485/422): 最多可連接 9台 PC/HMI/SCADA
 XP-8xx7-CE6: 最多可連接 9個 Modbus RTU Slave埠
 WP-8x37/8x47: 最多可連接 5個 Modbus RTU Slave埠
 VP-2xW7: 最多可連接 5個 Modbus RTU Slave埠
- Modbus TCP/IP: 最多可連接 64台 PC/HMI/SCADA
 XP-8xx7-CE6: 最多可連接 64個 Modbus TCP Slave 埠
 WP-8x37/8x47: 最多可連接 32個 Modbus TCP Slave 埠
 VP-2xW7: 最多可連接 32個 Modbus TCP Slave 埠

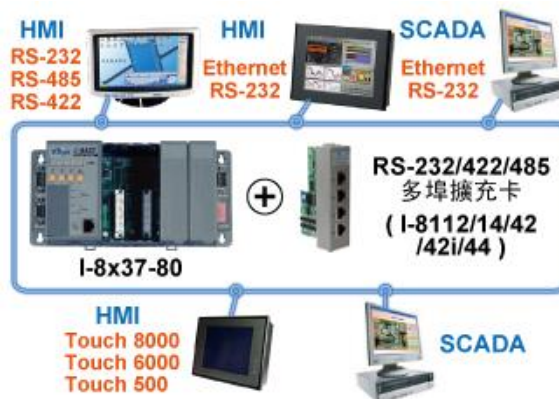

Modbus RTU/ASCII Master 埠

- | | | |
|---|---|---|
| <input checked="" type="checkbox"/> XP-8xx7-CE6 | <input checked="" type="checkbox"/> WP-8xx7 | <input checked="" type="checkbox"/> VP-2xW7 |
|---|---|---|

- Modbus RTU/ASCII (RS-232/485/422): 最多可連接 33台 Modbus 設備
 XP-8xx7-CE6: 最多可連接 **33**個Modbus RTU/ASCII Master埠
 WP-8xx7: 最多可連接 **10**個Modbus RTU/ASCII Master埠
 VP-2xW7: 最多可連接 **10**個Modbus RTU/ASCII Master埠

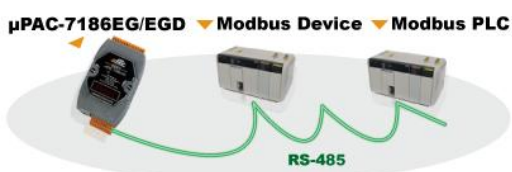

SMS: 簡訊服務

- | | | |
|---|---|---|
| <input checked="" type="checkbox"/> XP-8xx7-CE6 | <input checked="" type="checkbox"/> WP-8xx7 | <input checked="" type="checkbox"/> VP-2xW7 |
|---|---|---|

- 可整合 GSM Modem 來支援 SMS: 簡訊服務, 可用自己的手機來對 ISaGRAF 控制器詢問資料或下命令控制, 控制器也可以傳送資訊或警告訊息至使用者的手機
- 可傳送各國文字簡訊 ([FAQ-111](#))



遠程 I/O 模組 與 擴充模組/板卡

- | | | |
|---|---|---|
| <input checked="" type="checkbox"/> XP-8xx7-CE6 | <input checked="" type="checkbox"/> WP-8xx7 | <input checked="" type="checkbox"/> VP-2xW7 |
|---|---|---|

- XP-8xx7-CE6 (擴增 COM6~33)、WP-8xx7與VP-2xW7 (擴增 COM5~14) 可支援 RS-232/422/485 擴充模塊 (I-81xxW)

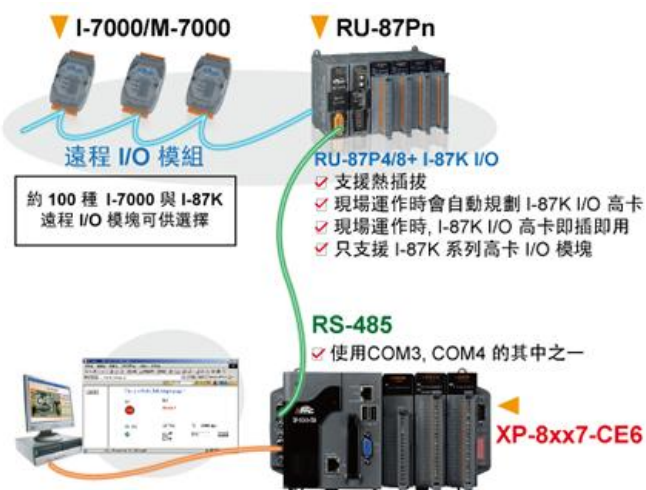

多重網路 (Web) 人機介面 – 隨處監控!

- | | | |
|---|---|---|
| <input checked="" type="checkbox"/> XP-8xx7-CE6 | <input checked="" type="checkbox"/> WP-8xx7 | <input checked="" type="checkbox"/> VP-2xW7 |
|---|---|---|

- 透過執行電腦中的網際網路瀏覽器 (IE) 來監視與控制本機或遠程的 I/O 模組

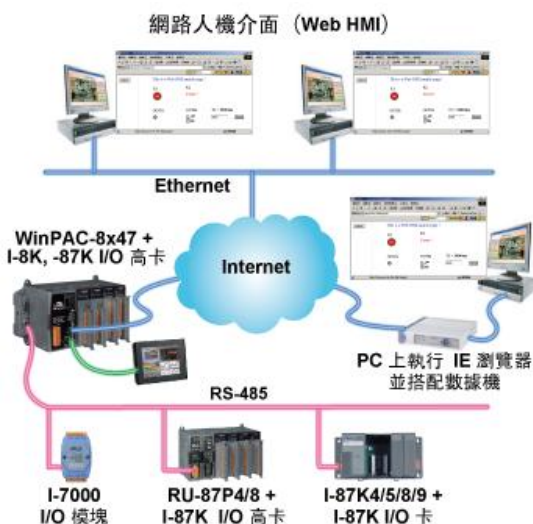

運動控制 (Motion Control)

- XP-8xx7-CE6
- WP-8xx7
- VP-2xW7

- 1個 I-8091W 可控制 2軸 :X-Y軸, 或 2軸獨立
- 2個 I-8091W 可控制 4軸 :X-Y軸 + 2軸獨立 或 4軸獨立
- Encoder 模組:
 - I-8093W : 3軸 (FAQ-112)
 - I-8084W : 4軸 (FAQ-100), 不支持 Z-index
 - I-8090W : 3軸



資料交換 - 透過 Fbus 或 Ebus

- XP-8xx7-CE6
- WP-8xx7
- VP-2xW7

- **Fbus (RS-485 網路) 或 Ebus (Ethernet 網路)**
- 每台 ISaGRAF PAC 可使用它的 RS-485 通訊串口或乙太網路連接埠, 並透過 Fbus 或 Ebus 通訊機制來相互交換資料. Ebus方式在配置上更加地靈活與快速

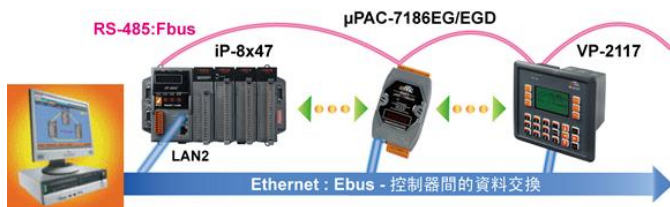

資料記錄器

- XP-8xx7-CE6
- WP-8xx7
- VP-2xW7

- 數據、日期/時間可被儲存 (例如: 電池備援SRAM, Flash 與 microSD卡, 選購的 X-board 與 XW-board 擴充卡..等), 且 PC 可藉由通訊介面來讀取這些資料 (例如: RS-232, RS-485, Ethernet 通訊串口..等)

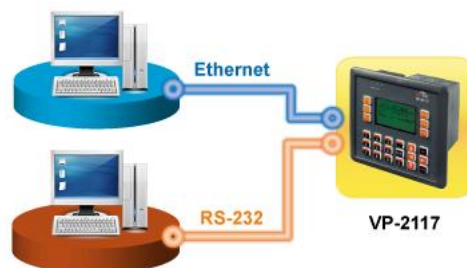

VIP 通訊安全

- XP-8xx7-CE6
- WP-8xx7
- VP-2xW7

- 在 ISaGRAF Workbench 軟體中, 可為 Modbus TCP/IP 作安全設定 (VIP: Very Important IP)

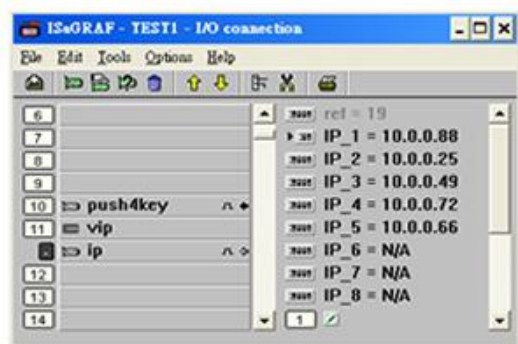

偵測 I-87K 高卡 I/O 之熱插拔 (Hot-Swap) 狀況

- XP-8xx7-CE6
- WP-8xx7
- VP-2xW7

- 在 ISaGRAF Workbench 軟體中, 正確地將 I/O 卡連結到 "I/O connection" 視窗, 並選用 "io_state" 卡來即時觀察 I/O 狀態. 當熱插拔 I-87K (高卡) I/O 時, 訊息會顯示在 PAC 的控制面板上

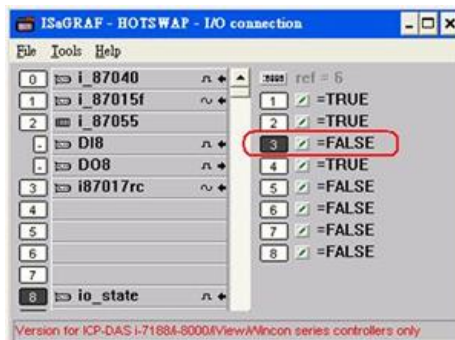

I/O 選型指南
高速本機 I/O 模組： 並列式 (Parallel Bus)
I-8K 高卡系列： 請詳見 www.icpdas.com > 繁體中文 > 產品介紹 > 可程式自動化控制器 - 8K & 87K I/O 模組

I-8K 類比 輸出入 模組	
I-8014W	16-bit 250K sampling rate 8/16-ch. analog input module (The scan rate cannot reach 250K when using in the ISaGRAF PAC)
I-8017HW	8-ch. Differential or 16-ch. Single-ended, 14-bit, High Speed Analog Input Module. (current input require external 125 Ω resistor) (The scan rate cannot reach 100K when using in the ISaGRAF PAC)
I-8024W	4-ch. Isolated Analog Output Module (+/-10 V, 0 ~ +20 mA)
I-8K 數位 輸出入 模組	
I-8037W	16-ch. Isolated Open Collector Output Module
I-8040W	32-ch. Isolated Digital Input Module
I-8040PW	32-ch. Isolated Digital Input with Low Pass Filter Module
I-8041W	32-ch. Isolated Open Collector Digital Output Module (Sink)
I-8041AW	32-ch. Isolated Open Collector Digital Output Module (Source)
I-8042W	16-ch. Isolated Digital Input & 16-ch. Isolated Open Collector Digital Output Module
I-8046W	16-ch. Isolated Digital Input Module
I-8050W	16-ch. Universal Digital I/O Module
I-8051W	16-ch. Non-isolated Digital Input Module
I-8052W	8-ch. Differential Isolated Digital Input Module
I-8053W	16-ch. Isolated Digital Input Module
I-8053PW	16-ch. Isolated Digital Input with Low Pass Filter Module
I-8054W	8-ch. Isolated Digital Input Module & 8-ch. Isolated Open Collector Digital Output Module
I-8055W	Non-isolated 8-ch. Digital Logic Input Module & 8-ch. Open Collector Digital Output Module
I-8056W	16-ch. Non-isolated Open Collector Output Module
I-8057W	16-ch. Isolated Open Collector Output Module
I-8058W	8-ch. Differential Isolated Digital Input Module, Max. AC/DC Input : 250V
I-8060W	6-ch. Relay Output Module, AC: 0.6 A @ 125 V , 0.3 A @ 250 V; DC: 2 A @ 30 V
I-8063W	4-ch. Differential Isolated digital input & 4-ch. Relay output module, AC : 0.6 A @ 125 V ; 0.3 A @ 250 V
I-8064W	8-ch. Power Relay Output Module, AC: 5 A @ 250 V, DC: 5 A @ 30 V
I-8068W	4-ch. Form-A, 5 A @ 250 V _{AC} /28 V _{DC} & 4-ch. Form-C, 5 A (NO) /3 A (NC) @ 277 V _{AC} /30 V _{DC} Relay Output Module
I-8069W	8-ch. PhotoMOS Relay Output Module, Max. AC/DC: 1 A @ 60 V
I-8K 計數器 / 頻率 模組	
I-8084W	4-ch. Encoder, can be dir/pulse, or up/down or A/B phase (Quad. mode), Not support Encoder Z-index
I-8088W	8-ch. PWM Output and 8-ch. isolated DI Module, software support 1 Hz ~ 100 kHz (non-continuous).
I-8K 運動控制 模組	
I-8093W	3-axis Encoder Module, max. 1M Hz for quadrant input mode, max. 4M Hz for pulse/direction and cw/ccw input model
I-8090W	3-axis Encoder Module
I-8091W	2-axis Stepping/Servo Motor Control Card without encoder input
I-8K 通訊 模組	
I-8135W	To expand the 2nd Ethernet port for the VP-25W7 / VP-23W7
I-8112iW	2-ch. Isolated RS-232 Expansion Module
I-8114W	4-ch. non-isolated RS-232 Expansion Module
I-8114iW	4-ch. Isolated RS-232 Expansion Module
I-8142iW	2-ch. Isolated RS-422/485 Expansion Module
I-8144iW	4-ch. Isolated RS-422/485 Expansion Module
I-8172W	2-port FRnet Module

RS-485 遠端 I/O 模組：串列式；可熱插拔

I-87K 高卡系列：請詳見 www.icpdas.com > 繁體中文 > 產品介紹 > 可程式自動化控制器 - 8K & 87K I/O 模組

I-87K 類比 輸出入 模組	
I-87005W	8-ch. Thermistor input and 8-ch. digital output module
I-87013W	4-ch., 16-bit, 10 Hz (Total), 2/3/4 Wire RTD Input Module with Open Wire Detection
I-87015W	7-ch., 16-bit, 12 Hz (Total), RTD Input Module with Open Wire Detection (for short sensor distance)
I-87015PW	7-ch. RTD Input Module with 3-wire RTD lead resistance elimination and with Open Wire Detection (for long sensor distance)
I-87017RW	8-ch. Differential , 16/12-bit, 10/60 Hz (Total) Analog Input Module with 240 V _{rms} Over Voltage Protection, Range of -20 ~ +20 mA Requires Optional External 125 Ω Resistor
I-87017RCW	8-ch. Differential , 16/12-bit, 10/60 Hz(Total) Current Input Module
I-87017W	8-ch. Analog Input Module
I-87017W-A5	8-ch. High Voltage Input Module
I-87018RW	8-ch. Thermocouple Input Module. Recommend to use the better I-87018Z.
I-87018W	8-ch. Thermocouple Input Module. Recommend to use the better I-87018Z.
I-87018ZW	10-ch. Differential , 16-bit, 10 Hz (Total), Thermocouple Input Module with 240 V _{rms} Over Voltage Protection, Open Wire Detection, Range of +/-20 mA, 0~20 mA, 4~20 mA requires Optional External 125 Ω Resistor
I-87019RW	8-ch. Diff. , 16-bit, 8 Hz (Total), Universal Analog Input Module with 240 V _{rms} Over Voltage Protection, Open Wire Detection (V, mA, Thermocouple; Range of -20 ~ +20 mA need to set Jumper on board)
I-87024CW	4-ch. 12-bit channel to channel isolated current output module with open-wire detection
I-87024W	4-ch. 14-bit analog output module (0 ~ +5 V, +/-5 V, 0 ~ +10 V, +/-10 V, 0 ~ +20 mA, +4 ~ +20 mA)
I-87028CW	8-ch. 12-bit current output module
I-87H17W	8-ch. analog input module and HART master module.
I-87K 數位 輸出入 模組	
I-87040W	32-ch. Isolated Digital Input Module
I-87041W	32-ch. Sink Type Open Collector Isolated Digital Output Module
I-87046W	16-ch. Non-Isolated Digital Input Module for Long Distance Measurement
I-87051W	16-ch. Non-Isolated Digital Input Module
I-87052W	8-ch. Differential , Isolated Digital Input Module
I-87053PW	16-ch. Isolated Digital Input Module with 16-bit Counters
I-87053W	16-ch. Isolated Digital Input Module
I-87053W-A5	16-ch. 68 ~ 150 V _{DC} Isolated Digital Input Module
I-87054W	Isolated 8-ch. DI and 8-ch. Open Collector DO Module
I-87055W	Non-Isolated 8-ch. DI and 8-ch. Open Collector DO Module
I-87057W	16-ch. Open Collector Isolated Digital Output Module
I-87058W	8-ch. 80~250 V _{AC} Isolated Digital Input Module
I-87059W	8-ch. Differential 10-80 VAC Isolated Digital Input Module
I-87061W	16-ch. Relay Output Module (RoHS)
I-87063W	4-ch. Differential Isolated Digital Input and 4-ch. Relay Output Module 5 A (NO) / 3 A(NC) @ 5 ~ 24 V _{DC} ; 5 A(NO) / 3 A(NC) @ 0 ~ 250 V _{AC}
I-87064W	8-ch. Relay Output Module, 5 A (47~63 Hz) @ 0~ 250 V _{AC} ; 5 A @ 0~ 30 V _{DC}
I-87065W	8-ch. AC SSR Output Module, AC: 1.0 A _{rms} @ 24 ~ 265 V _{rms}
I-87066W	8-ch. DC SSR Output Module , DC: 1.0 A _{rms} @ 3 ~ 30 V _{DC}
I-87068W	4-ch. Form-A Relay Output and 4-ch. Form-C Relay Output Module ; Form-A: 8 A @ 250 V _{AC} ; 8 A @ 28 V _{DC} ; Form-C: 5 A (NO) / 3 A (NC) @ 277 V _{AC} ; 5 A(NO) / 3 A(NC) @ 30 V _{AC}
I-87069W	8-ch. PhotoMOS Relay Output Module, Max. AC/DC: 0.13 A @ 350 V
I-87K 計數器 / 頻率 模組	
I-87082W	2-ch. Counter/Frequency Module, Isolated or Non-isolated Inputs
I-87K PWMS 模組	
I-87088W	8-ch. PWM outputs, software support 1 Hz~100 kHz, (non-continuous), duty: 0.1 ~ 99.9%
I-87K GPS 模組	
I-87211W	Time-Synchronization and GPS module for getting UTC/local time and local Longitude/Latitude

RS-485 遠程 I/O 模組	
I-7000	 Products > Remote I/O Modules/Units > I-7000 Modules > Selection Guide">www.icpdas.com > Products > Remote I/O Modules/Units > I-7000 Modules > Selection Guide
M-7000	 Products > Remote I/O Modules/Units > M-7000 Modules > Selection Guide">www.icpdas.com > Products > Remote I/O Modules/Units > M-7000 Modules > Selection Guide
RS-485 遠程可熱插拔 (Hot-Swap) 擴充單元	
RU-87P1/2/4/8	 Products > Remote I/O Modules/Units > Remote I/O Expansion Unit > Selection Guide">www.icpdas.com > Products > Remote I/O Modules/Units > Remote I/O Expansion Unit > Selection Guide
RS-485 遠程擴充單元	
I-87K1/4/5/8/9	 Products > Remote I/O Modules/Units > Remote I/O Expansion Unit > Selection Guide">www.icpdas.com > Products > Remote I/O Modules/Units > Remote I/O Expansion Unit > Selection Guide