



## EMC Test Report

Product Type : ICP DAS I/O System  
Applicant : ICP DAS CO., LTD.  
Address : No. 111, Guangfu N. Rd., Hukou Township, Hsinchu County 30351, Taiwan, R.O.C.  
Trade Name : ICP DAS  
Model Number : PM-3033, PM-3033-MTCP, PM-3033-CPS  
Test Specification : EN 61326-1: 2013, Table 1  
IEC 61326-1: 2012  
EN 55011: 2009 + A1: 2010 , (Class A)  
EN 61000-4-2: 2009  
EN 61000-4-3: 2006 +A1:2008 +A2:2010  
EN 61000-4-4: 2012  
EN 61000-4-5: 2006  
EN 61000-4-6: 2009  
Receive Date : Sep. 01, 2015  
Test Period : Sep. 09 ~ 11, 2015  
Issue Date : Oct. 06, 2015

### Issue by

A Test Lab Techno Corp.  
No. 140-1, Changan Street, Bade City,  
Taoyuan County 334, Taiwan R.O.C.  
Tel : +886-3-2710188 / Fax : +886-3-2710190



Taiwan Accreditation Foundation accreditation number: 1330

**Note:** This report shall not be reproduced except in full, without the written approval of A Test Lab Techno Corp. This document may be altered or revised by A Test Lab Techno Corp. personnel only, and shall be noted in the revision section of the document. The client should not use it to claim product endorsement by TAF, or any government agencies. The test results in the report only apply to the tested sample.

**Revision History**

<b>Rev.</b>	<b>Issue Date</b>	<b>Revisions</b>	<b>Revised By</b>
00	Sep. 30, 2015	Initial Issue	
01	Oct. 06, 2015	Revised report information.	Nico Peng

## Verification of Compliance

Issued Date: 2015/10/06

Product Type : ICP DAS I/O System  
Applicant : ICP DAS CO., LTD.  
Address : No. 111, Guangfu N. Rd., Hukou Township, Hsinchu County  
30351, Taiwan, R.O.C.  
Trade Name : ICP DAS  
Model Number : PM-3033, PM-3033-MTCP, PM-3033-CPS  
EUT Rated Voltage : AC 100-250V, 50-60Hz, 2.0A  
Test Voltage : 230 Vac / 50 Hz  
Applicable Standard : EN 61326-1: 2013, Table 1  
IEC 61326-1: 2012  
EN 55011: 2009 + A1: 2010 , (Class A)  
EN 61000-4-2: 2009  
EN 61000-4-3: 2006 +A1:2008 +A2:2010  
EN 61000-4-4: 2012  
EN 61000-4-5: 2006  
Test Result : Complied  
Performing Lab. : A Test Lab Techno Corp.  
No. 140-1, Changan Street, Bade City,  
Taoyuan County 334, Taiwan R.O.C.  
Tel : +886-3-2710188 / Fax : +886-3-2710190  
Taiwan Accreditation Foundation accreditation number: 1330  
<http://www.atl-lab.com.tw/e-index.htm>

The above equipment has been tested by A Test Lab Techno Corp., and found compliance with the requirements set forth in the Directive 93/42/EEC concerning medical devices and technical standards mentioned above. The results of testing in this report apply only to the product/system, which was tested. Other similar equipment will not necessarily produce the same results due to production tolerance and measurement uncertainties.

Approved By : *Misty Wu*

Reviewed By

: *Frank Lin*

(Manager)

(Misty Wu)

(Testing Engineer)

(Frank Lin)

## TABLE OF CONTENTS

<b>1</b>	<b>General Information .....</b>	<b>5</b>
<b>2</b>	<b>EUT Description.....</b>	<b>8</b>
<b>3</b>	<b>Test Methodology.....</b>	<b>9</b>
	3.1. Decision of Test Mode.....	9
	3.2. EUT Exercise Software.....	9
	3.3. Configuration of Test System Details .....	10
	3.4. Test Site Environment.....	13
<b>4</b>	<b>Emission Test .....</b>	<b>14</b>
	4.1. Conducted Emission Measurement .....	14
	4.2. Radiated Emission Measurement .....	23
	4.3. Voltage Fluctuation and Flicker .....	34
<b>5</b>	<b>Immunity Test .....</b>	<b>38</b>
	5.1. Electrostatic Discharge (ESD).....	38
	5.2. Radiated Electromagnetic Field (RS).....	49
	5.3. Electrical Fast Transient/Burst (EFT) .....	53
	5.4. Surge .....	56
	5.5. Conducted Susceptibility (CS) .....	59
	5.6. Power Frequency Magnetic Field (PMF).....	63
	5.7. Voltage Dips and Interruption.....	66
<b>6</b>	<b>EUT Photograph .....</b>	<b>69</b>

# 1 General Information

## 1.1 Summary of Test Result

Emission			
Standard	Item	Result	Remark
EN 55011: 2009+A1:2010	Conducted	PASS	Meet Class A limit
EN 55011: 2009+A1:2010	Radiated	PASS	Meet Class A limit
EN 61000-3-2: 2006+A1:2009+A2:2009	Harmonic current emissions	PASS	Meet Class A limit
EN 61000-3-3:2013	Voltage fluctuations & flicker	PASS	Meets the requirements

Immunity			
Standard	Item	Result	Remark
IEC 61000-4-2:2008	ESD	PASS	Meets the requirements of Performance Criterion B
IEC 61000-4-3:2006 +A1:2007 +A2:2010	RS	PASS	Meets the requirements of Performance Criterion A
IEC 61000-4-4:2004	EFT	PASS	Meets the requirements of Performance Criterion B
IEC 61000-4-5:2005	Surge	PASS	Meets the requirements of Performance Criterion B
IEC 61000-4-6:2008	CS	PASS	Meets the requirements of Performance Criterion A
EN 61000-4-8: 2010	PMF	PASS	Meets the requirements of Criterion A
IEC 61000-4-11:2004	Voltage dips & voltage variations	PASS	Meets the requirements of Voltage Dips: 1) 100% reduction Performance Criterion B 2) 60% reduction Performance Criterion C 3) 30% reduction Performance Criterion C Voltage Interruptions: 1) 100% reduction Performance Criterion C

The statements of test result on the above are decided by the request of test standard only; the measurement uncertainties are not factored into this compliance determination.

The information of measurement uncertainty is available upon the customer's request.

## 1.2 Measurement Uncertainty

### Conducted Emission

The measurement uncertainty is evaluated as 2.8 dB.

### Conducted Emissions (Telecommunication Ports)

The measurement uncertainty is evaluated as 3.1 dB.

### Radiated Emission

The Horizontal measurement uncertainty of 30MHz - 1GHz is evaluated as 5.2 dB.

The Vertical measurement uncertainty of 30MHz - 1GHz is evaluated as 5.5 dB.

### Harmonic Current Emission

The measurement uncertainty is evaluated as 36 mA/A.

### Voltage Fluctuations and Flicker

The measurement uncertainty is evaluated as 4.4 mV/V.

### Electrostatic Discharge

As what is concluded in the document from Note2 of clause 5.4.6.2 of ISO/IEC 17025: 2005[E], the requirements for measurement uncertainty in ESD testing are deemed to have been satisfied, and the testing is reported in accordance with the relevant ESD standards. The immunity test signal from the ESD system meet the required specifications in IEC 61000-4-2 through the calibration report with the calibrated uncertainty for the waveform of voltage / Current / timing as being 0.86 % / 2.5 % / 6.0 %.

### Radiated susceptibility

As what is concluded in the document from Note2 of clause 5.4.6.2 of ISO/IEC 17025: 2005[E], the requirements for measurement uncertainty in RS testing are deemed to have been satisfied, and the testing is reported in accordance with the relevant RS standards. The immunity test signal from the RS system meet the required specifications in IEC 61000-4-3 through the calibration for the uniform field strength and monitoring for the test level with the uncertainty evaluation report for the electrical field strength as being 3.2 dB.

### Electrical fast transient/burst

As what is concluded in the document from Note2 of clause 5.4.6.2 of ISO/IEC 17025: 1999[2], the requirements for measurement uncertainty in EFT/Burst testing are deemed to have been satisfied, and the testing is reported in accordance with the relevant FT/Burst standards. The immunity test signal from the FT/Burst system meet the required specifications in IEC 61000-4-4 through the calibration report with the calibrated uncertainty as 2 %.

### Surge

As what is concluded in the document from Note2 of clause 5.4.6.2 of ISO/IEC 17025: 2005[E], the requirements for measurement uncertainty in Surge testing are deemed to have been satisfied, and the testing is reported in accordance with the relevant Surge standards. The immunity test signal from the Surge system meet the required specifications in IEC 61000-4-5 through the calibration report with the calibrated uncertainty for the waveform of voltage / current / timing as being 3%.

### Conducted susceptibility

As what is concluded in the document from Note2 of clause 5.4.6.2 of ISO/IEC 17025: 2005[E], the requirements for measurement uncertainty in CS testing are deemed to have been satisfied, and the testing is reported in accordance with the relevant CS standards. The immunity test signal from the CS system meet the required specifications in IEC 61000-4-6 through the calibration for unmodulated signal and monitoring for the test level with the uncertainty evaluation report for the injected modulated signal level through CDN and EM Clamp/Direct Injection as being 3.8 dB and 2.8 dB.

Power frequency magnetic field

As what is concluded in the document from Note2 of clause 5.4.6.2 of ISO/IEC 17025: 2005[E], the requirements for measurement uncertainty in PFM testing are deemed to have been satisfied, and the testing is reported in accordance with the relevant PFM standards. The immunity test signal from the PFM system meet the required specifications in IEC 61000-4-8 through the calibration report with the calibrated uncertainty for the Gauss Meter to verify the output level of magnetic field strength as being 36mA/A

Voltage dips and interruption

As what is concluded in the document from Note2 of clause 5.4.6.2 of ISO/IEC 17025: 2005[E], the requirements for measurement uncertainty in DIP testing are deemed to have been satisfied, and the testing is reported in accordance with the relevant DIP standards. The immunity test signal from the DIP system meet the required specifications in IEC 61000-4-11 through the calibration report with the calibrated uncertainty for the waveform of voltage and timing as being 1.004 %.

## 2 EUT Description

Product Type	:	ICP DAS I/O System
Trade Name	:	ICP DAS
Model Number	:	PM-3033, PM-3033-MTCP, PM-3033-CPS (These model numbers difference is showed on difference description.)
Applicant	:	ICP DAS CO., LTD. No. 111, Guangfu N. Rd., Hukou Township, Hsinchu County 30351, Taiwan, R.O.C.
Manufacturer	:	ICP DAS CO., LTD. No. 111, Guangfu N. Rd., Hukou Township, Hsinchu County 30351, Taiwan, R.O.C.

### Difference Description :

Main	Diversity	Mode 1
PM-3033	Modbus RTU, 3-phase power meter (1A/5A CT Input type)	V
PM-3033-MTCP	Modbus TCP, 3-phase power meter (1A/5A CT Input type)	
PM-3033-CPS	CANopen, 3-phase power meter (1A/5A CT Input type)	

### I/O Port Description :

I/O Port Types	Q'TY	Test Description
1). DC Power Port	1	Connected to EUT
2). AC Power Port	1	Connected to AC Source
3). LAN Port	2	Connected to EUT



### 3 Test Methodology

#### 3.1. Decision of Test Mode

3.1.1. The following test mode(s) were scanned during the preliminary test:

Pre-Test Mode	
Mode 1: Normal Operation Mode	

3.1.2. After the preliminary scan, the following test mode was found to produce the highest emission level.

Final Test Mode			
Emission	Conducted Emission		Mode 1
	Radiated Emission	Below 1GHz	Mode 1
		Above 1GHz	Mode 1
	Harmonic current emissions		Mode 1
Voltage fluctuations & flicker		Mode 1	
Immunity	ESD		Mode 1
	RS		Mode 1
	EFT		Mode 1
	Surge		Mode 1
	CS		Mode 1
	PMF		Mode 1
	Voltage dips & voltage variations		Mode 1

Then, the above highest emission mode of the configuration of the EUT and cable was chosen for all final test items. The test items IEC 61000-4-4, IEC 61000-4-5 & IEC 61000-4-11 were performed at the minimum and maximum RATED input voltages. The worst case (Input: 230VAC) was precisely noted in the test report only. Please refer to the following test result.

#### 3.2. EUT Exercise Software

1. Setup the EUT and simulators as shown on 3.3.
2. Turn on the power of all equipment.
3. The EUT will start to operate function.

### 3.3. Configuration of Test System Details

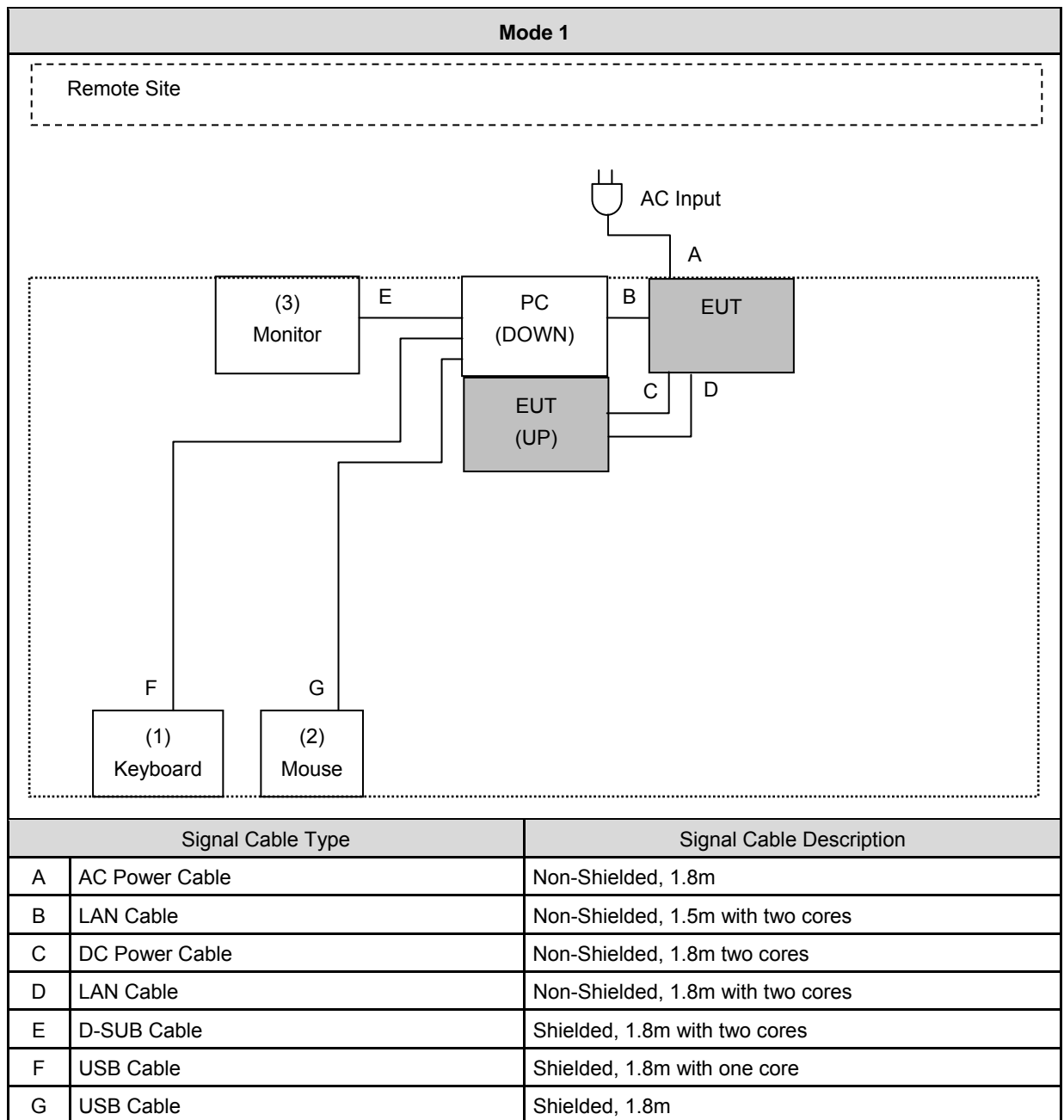

Devices Description					
Product	Manufacturer	Model Number	Serial Number	Power Cord	
1.	Keyboard	Microsoft	1366	66903907570	Power by PC
2.	Mouse	DELL	MOC5UO	I0S02009	Power by PC
3.	Monitor	DELL	U2410f	CN-OJ257M-72872-09J-0 1AL	Non-Shielded, 1.8m
※ PC Keypart information					
Main	Software	Diversity		Mode 1	
PCI-P8POR8U	---	Universal PCI, 8-channel Isolated Digital Input and 8-channel Photo-MOS Relay Output		√	
PCI-P16POR16	---	16-channel isolated digital input. 16-channel PhotoMos Relay output. Includes one CA-4037W cable and two CA-4002 D-Sub connectors.			
PCI-P16POR16U	---	Universal PCI, 16-channel Isolated Digital Input and 16-channel Photo-MOS Relay Output			
PEX-P32A32	---	PCI Express, 32-channel Isolated Digital Input and 32-channel Isolated Open-collector output Board		√	
PEX-P32C32	---	PCI Express, 32-channel Optically Isolated Digital Input and 32-channel Optically Isolated Digital Open-collector output Board. (Current Sinking) Includes one CA-4037B cable and two CA-4002 D-Sub connectors.			
PISO-PS400	---	PCI Bus, High Speed 4-axis Motion Control Card		√	
PCI-2602U	---	Universal PCI, 1 MS/s High-Speed, 16-channel Analog Input, 2-channel Analog Output and 32-channel DIO		√	
PIO-DA4	---	PCI bus 4-channel D/A board. Includes one CA-4002 D-Sub connector.			
PIO-DA4/S	---	PCI bus 4-channel D/A board Includes DN-37.			
PIO-DA4U	---	Universal PCI 4-channel D/A board Includes one CA-4002 D-Sub connector.			
PIO-DA4U/S	---	PIO-DA4U with DN-37 Includes one CA-3710 D-Sub cable.			
PIO-DA8	---	PCI bus 8-channel D/A board. Includes one CA-4002 D-Sub connector.			
PIO-DA8/S	---	PCI bus 8-channel D/A board Includes DN-37.			
PIO-DA8U	---	Universal PCI 8-channel D/A board Includes one CA-4002 D-Sub connector.			
PIO-DA8U/S	---	PIO-DA8U with DN-37 Includes one CA-3710 D-Sub cable.			
PIO-DA16	---	PCI bus 16-channel D/A board. Includes one CA-4002 D-Sub connector.			
PIO-DA16/S	---	PCI bus 16-channel D/A board Includes DN-37.			
PIO-DA16U	---	Universal PCI 16-channel D/A board Includes one CA-4002 D-Sub connector.		√	
PIO-DA16U/S	---	PIO-DA16U with DN-37 Includes one CA-3710 D-Sub cable.			
PISO-A64	---	64-channel Optically Isolated Open-Collector Digital Output Board (Current Sourcing) Includes one CA-4037B cable and two CA-4002 D-Sub connectors.		√	
PISO-730	---	32-channel isolated digital I/O (Input Logic High: 9~24 V) & 32-channel TTL digital I/O board. (current sinking) Includes one CA-4002 D-Sub connector.			

Main	Software	Diversity	Mode 1
PISO-730-5V	---	Universal PCI Bus, 32-channel isolated digital I/O (Input Logic High: 5~12 V) & 32-channel TTL digital I/O board. (current sinking)	
PISO-730U	---	Universal PCI Bus, 32-channel isolated digital I/O (Input Logic High: 9~24 V) & 32-channel TTL digital I/O board. (current sinking)	V
PISO-730A	---	32-channel isolated digital I/O & 32-channel TTL digital I/O board. (current sourcing) Includes one CA-4002 D-Sub connector.	V
PISO-730A-5V	---	32-channel isolated digital I/O (Input Logic High: 5~12 V) & 32-channel TTL digital I/O board. (current sourcing) Includes one CA-4002 D-Sub connector.	
PISO-730AU	---	Universal PCI 32-channel isolated digital I/O (Input Logic High: 5~12 V) & 32-channel TTL digital I/O board. (current sourcing) Includes one CA-4002 D-Sub connector.	
PEX-1202H	---	32-ch, 12-bit, 44 kS/s High Gain Multi-function DAQ Board (1 K word FIFO) Includes one CA-4002 D-Sub connector.	
PEX-1202L	---	32-ch, 12-bit, 110 kS/s Low Gain Multi-function DAQ Board (1 K word FIFO) Includes one CA-4002 D-Sub connector.	V
PEX-D96S		PCI Express, 96-channel DIO board (SCSI II Connector, RoHS)	

Support Unit					
	Product	Manufacturer	Model Number	Serial Number	Power Cord
1.	Industrial Power Supply	ICP DAS	DP-1200	N/A	Non-Shielded, 1.7m with one core

### 3.4. Test Site Environment

Items	Test Item	Required (IEC 60068-1)	Actual
Temperature (°C)	EN55011 CE	15-35	26.0
Humidity (%RH)		25-75	60.0
Barometric pressure (mbar)		860-1060	950
Temperature (°C)	EN55011 RE	15-35	26.0
Humidity (%RH)		25-75	60.0
Barometric pressure (mbar)		860-1060	950
Temperature (°C)	EN 61000-3-3	--	26.0
Humidity (%RH)		--	60.0
Barometric pressure (mbar)		--	950
Temperature (°C)	IEC 61000-4-2	15-35	26.0
Humidity (%RH)		30-60	60.0
Barometric pressure (mbar)		860-1060	950
Temperature (°C)	IEC 61000-4-3	--	23.4
Humidity (%RH)		--	45.8
Barometric pressure (mbar)		--	950
Temperature (°C)	IEC 61000-4-4	15-35	24.6
Humidity (%RH)		30-60	51.2
Barometric pressure (mbar)		860-1060	950
Temperature (°C)	IEC 61000-4-5	15-35	24.7
Humidity (%RH)		10-75	49.8
Barometric pressure (mbar)		860-1060	950
Temperature (°C)	IEC 61000-4-6	--	24.7
Humidity (%RH)		--	49.8
Barometric pressure (mbar)		--	950
Temperature (°C)	IEC 61000-4-8	15-35	25.8
Humidity (%RH)		25-75	47.2
Barometric pressure (mbar)		860-1060	950
Temperature (°C)	IEC 61000-4-11	15-35	24.7
Humidity (%RH)		25-75	49.8
Barometric pressure (mbar)		860-1060	950

## 4 Emission Test

### 4.1. Conducted Emission Measurement

#### 4.1.1. Limit

Frequency (MHz)	Class A (dBuV)		Class B (dBuV)	
	Quasi-peak	Average	Quasi-peak	Average
0.15 - 0.5	79	66	66 - 56	56 - 46
0.50 - 5.0	73	60	56	46
5.0 - 30.0	73	60	60	50

- Note:
- (1) The lower limit shall apply at the transition frequencies.
  - (2) The limit decreases in line with the logarithm of the frequency in the range 0.15 to 0.50 MHz.
  - (3) All emanations from a class A/B digital device or system, including any network of conductors and apparatus connected thereto, shall not exceed the level of field strengths specified above.

#### 4.1.2. Test Instruments

Equipment	Manufacturer	Model Number	Serial Number	Cal. Date	Cal. Period
Test Receiver	R&S	ESCI	100367	06/25/2015	1 year
LISN	R&S	ENV216	101040	03/10/2015	1 year
LISN	R&S	ENV216	101041	03/06/2015	1 year
T-LISN	FCC	FCC-TLISN-T2-02	20574	03/31/2015	1 year
T-LISN	FCC	FCC-TLISN-T4-02	20529	04/02/2015	1 year
T-LISN	TESEQ	ISN-T8	34413	04/27/2015	1 year
Spectrum Analyzer	Advantest	R3132	160300103	N.C.R.	-----
Transient Limiter	ELECTRO-METRICS	EM-7600	777	N.C.R.	-----
Test Site	ATL	TE02	TE02	N.C.R.	-----

Note: N.C.R. = No Calibration Request.

### 4.1.3. Test Setup

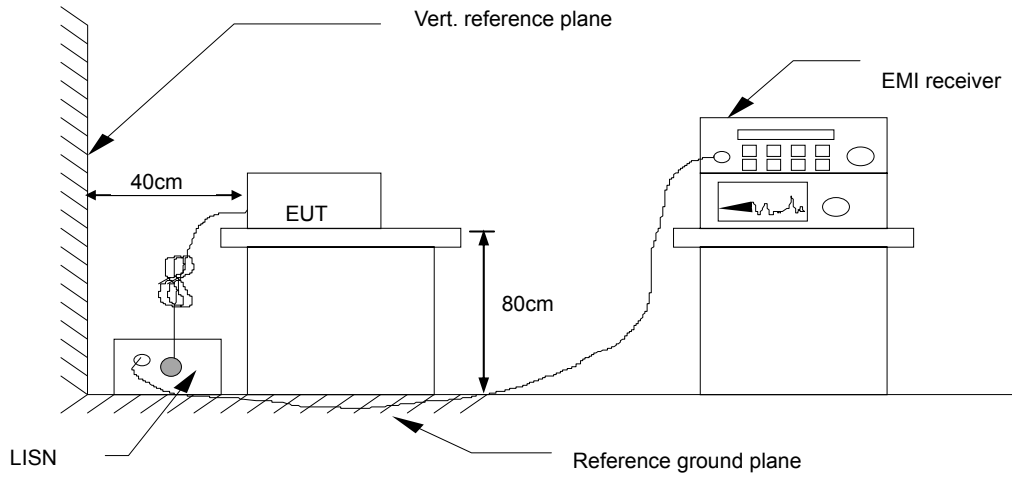

#### 4.1.4. Test Procedure

##### **Procedure of Preliminary Test**

The EUT was set up as per the test configuration to simulate typical usage per the user's manual. When the EUT is a tabletop system, a wooden table with a height of 0.8 meters is used and is placed on the ground plane as per EN 55011 (see Test Facility for the dimensions of the ground plane used). When the EUT is a floor-standing equipment, it is placed on the ground plane which has a 15 cm non-conductive covering to insulate the EUT from the ground plane.

Support equipment, if needed, was placed as per EN 55011.

All I/O cables were positioned to simulate typical actual usage as per EN 55011.

The test equipment EUT installed received AC power, 230VAC/50Hz, through a Line Impedance Stabilization Network (LISN), which supplied power source and was grounded to the ground plane.

All support equipment received power from a second LISN.

The EUT test program was started. Emissions were measured on each current carrying line of the EUT using an EMI Test Receiver connected to the LISN powering the EUT.

The Receiver scanned from 150kHz to 30MHz for emissions in each of the test modes.

During the above scans, the emissions were maximized by cable manipulation.

The test mode(s) described in Item 3.2 were scanned during the preliminary test.

After the preliminary scan, we found the test mode described in Item 3.2 producing the highest emission level.

The worst configuration of EUT and cable of the above highest emission level were recorded for reference of the final test.

##### **Procedure of Final Test**

EUT and support equipment were set up on the test bench as per the configuration with highest emission level in the preliminary test.

A scan was taken on both power lines, Line 1 and Line 2, recording at least the six highest emissions. Emission frequency and amplitude were recorded into a computer in which correction factors were used to calculate the emission level and compare reading to the applicable limit. If EUT emission level was less  $-2\text{dB}$  to the Average limit in Q.P. mode, then the emission signal was re-checked using an Average detector.

The test data of the worst-case condition(s) was recorded.



**4.1.5. Test Result**

Standard:	EN 55011	Line:	L1
Test item:	Conducted Emission	Power:	AC 230V/50Hz
Model Number:	PM-3033	Temp.(°C)/Hum.(%RH):	26(°C)/60%RH
Mode:	Mode 1	Date:	2015/09/10
		Test By:	Frank Lin
Description:			

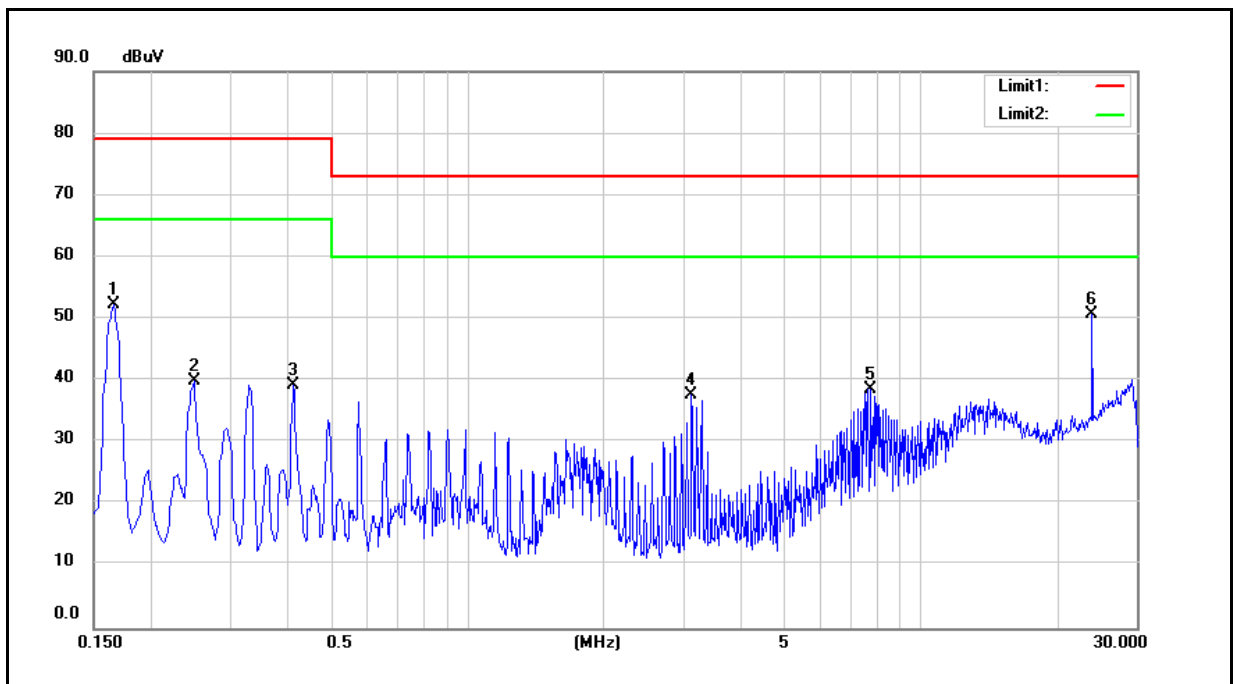

No.	Frequency (MHz)	QP reading (dBuV)	AVG reading (dBuV)	Correction factor (dB)	QP result (dBuV)	AVG result (dBuV)	QP limit (dBuV)	AVG limit (dBuV)	QP margin (dB)	AVG margin (dB)	Remark
1	0.1660	43.68	41.51	9.58	53.26	51.09	79.00	66.00	-25.74	-14.91	Pass
2	0.2500	31.69	28.45	9.59	41.28	38.04	79.00	66.00	-37.72	-27.96	Pass
3	0.4140	28.66	24.89	9.59	38.25	34.48	79.00	66.00	-40.75	-31.52	Pass
4	3.1340	25.56	15.44	9.70	35.26	25.14	73.00	60.00	-37.74	-34.86	Pass
5	7.7740	22.96	20.77	9.84	32.80	30.61	73.00	60.00	-40.20	-29.39	Pass
6	23.9900	39.65	39.10	10.15	49.80	49.25	73.00	60.00	-23.20	-10.75	Pass

Note: 1. Result (dBuV) = Correction factor (dB) + Reading(dBuV).

2. Correction factor (dB) = Cable loss (dB) + L.I.S.N. factor (dB).

Standard:	EN 55011	Line:	N
Test item:	Conducted Emission	Power:	AC 230V/50Hz
Model Number:	PM-3033	Temp.(°C)/Hum.(%RH):	26(°C)/60%RH
Mode:	Mode 1	Date:	2015/09/10
		Test By:	Frank Lin
Description:			

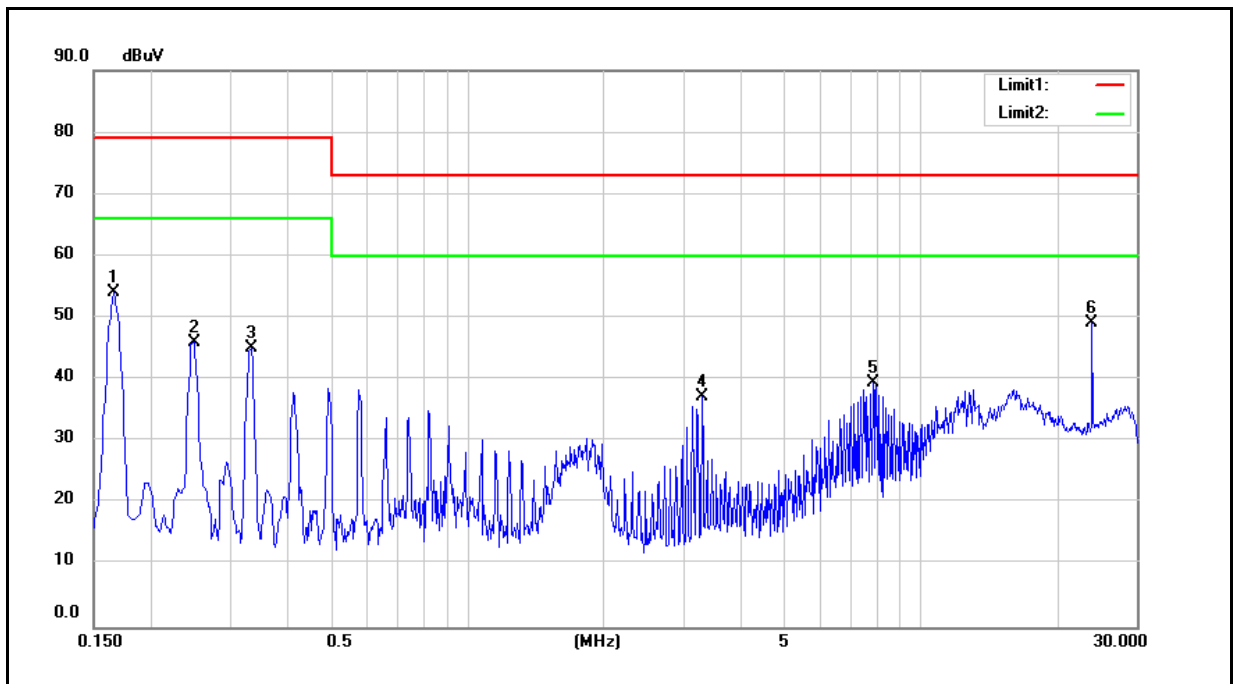

No.	Frequency (MHz)	QP reading (dBuV)	AVG reading (dBuV)	Correction factor (dB)	QP result (dBuV)	AVG result (dBuV)	QP limit (dBuV)	AVG limit (dBuV)	QP margin (dB)	AVG margin (dB)	Remark
1	0.1660	43.41	39.65	9.58	52.99	49.23	79.00	66.00	-26.01	-16.77	Pass
2	0.2500	35.42	32.39	9.59	45.01	41.98	79.00	66.00	-33.99	-24.02	Pass
3	0.3340	34.40	29.52	9.59	43.99	39.11	79.00	66.00	-35.01	-26.89	Pass
4	3.3060	25.25	13.61	9.73	34.98	23.34	73.00	60.00	-38.02	-36.66	Pass
5	7.8900	23.75	21.48	9.86	33.61	31.34	73.00	60.00	-39.39	-28.66	Pass
6	23.9900	38.44	37.91	10.18	48.62	48.09	73.00	60.00	-24.38	-11.91	Pass

Note: 1. Result (dBuV) = Correction factor (dB) + Reading(dBuV).

2. Correction factor (dB) = Cable loss (dB) + L.I.S.N. factor (dB).

Standard:	ISN(Voltage)	Line:	N/A
Test item:	Conducted Emission	Power:	AC 230V/50Hz
Model Number:	PM-3033	Temp.(°C)/Hum.(%RH):	26(°C)/60%RH
Mode:	Mode 1 (ISN 10M)	Date:	2015/09/10
		Test By:	Frank Lin
Description:			

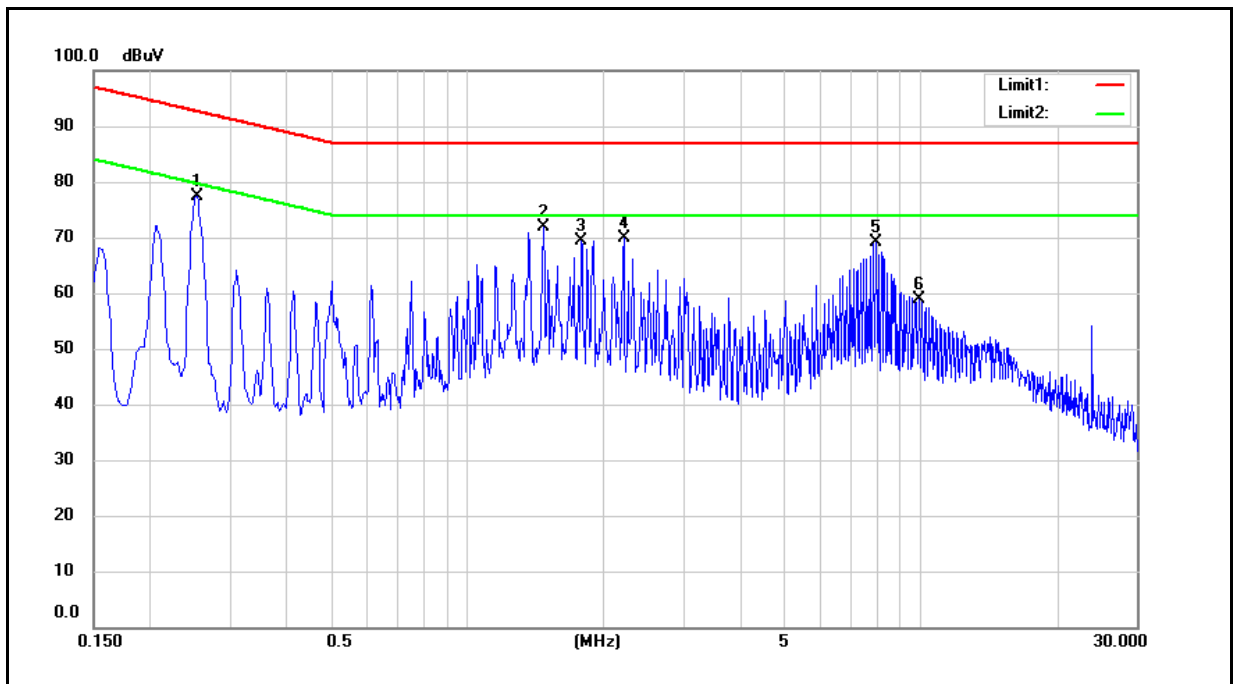

No.	Frequency (MHz)	QP reading (dBuV)	AVG reading (dBuV)	Correction factor (dB)	QP result (dBuV)	AVG result (dBuV)	QP limit (dBuV)	AVG limit (dBuV)	QP margin (dB)	AVG margin (dB)	Remark
1	0.2540	65.16	64.24	10.25	75.41	74.49	92.63	79.63	-17.22	-5.14	Pass
2	1.4740	60.87	58.82	9.96	70.83	68.78	87.00	74.00	-16.17	-5.22	Pass
3	1.7900	55.80	54.86	9.94	65.74	64.80	87.00	74.00	-21.26	-9.20	Pass
4	2.2140	58.12	56.88	9.95	68.07	66.83	87.00	74.00	-18.93	-7.17	Pass
5	7.9900	56.15	53.91	9.99	66.14	63.90	87.00	74.00	-20.86	-10.10	Pass
6	10.0000	33.84	26.18	10.02	43.86	36.20	87.00	74.00	-43.14	-37.80	Pass

Note: 1. Result (dBuV) = Correction factor (dB) + Reading(dBuV).

2. Correction factor (dB) = Cable loss (dB) + L.I.S.N. factor (dB).

Standard:	ISN(Voltage)	Line:	N/A
Test item:	Conducted Emission	Power:	AC 230V/50Hz
Model Number:	PM-3033	Temp.(°C)/Hum.(%RH):	26(°C)/60%RH
Mode:	Mode 1 (ISN 100M)	Date:	2015/09/10
		Test By:	Frank Lin
Description:			

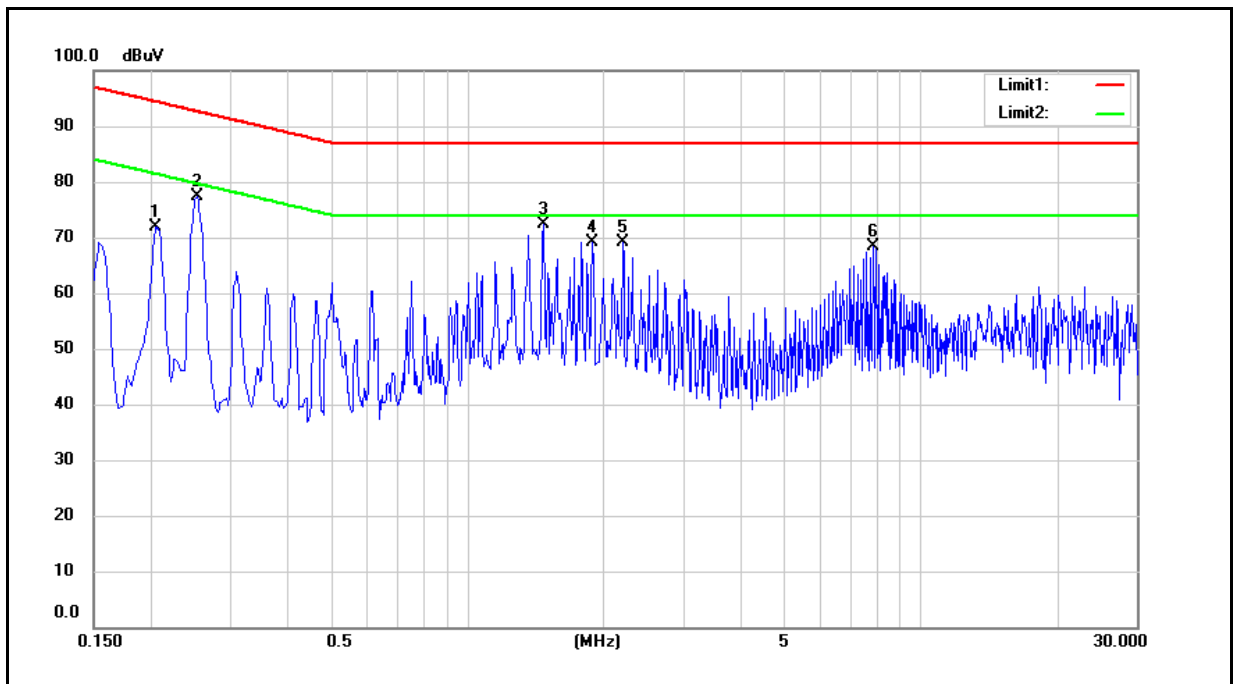

No.	Frequency (MHz)	QP reading (dBuV)	AVG reading (dBuV)	Correction factor (dB)	QP result (dBuV)	AVG result (dBuV)	QP limit (dBuV)	AVG limit (dBuV)	QP margin (dB)	AVG margin (dB)	Remark
1	0.2060	61.54	58.52	10.28	71.82	68.80	94.37	81.37	-22.55	-12.57	Pass
2	0.2540	65.34	64.41	10.25	75.59	74.66	92.63	79.63	-17.04	-4.97	Pass
3	1.4740	62.43	61.03	9.96	72.39	70.99	87.00	74.00	-14.61	-3.01	Pass
4	1.8940	58.48	57.56	9.95	68.43	67.51	87.00	74.00	-18.57	-6.49	Pass
5	2.2100	58.47	56.94	9.95	68.42	66.89	87.00	74.00	-18.58	-7.11	Pass
6	7.8700	58.16	57.16	9.99	68.15	67.15	87.00	74.00	-18.85	-6.85	Pass

Note: 1. Result (dBuV) = Correction factor (dB) + Reading(dBuV).

2. Correction factor (dB) = Cable loss (dB) + L.I.S.N. factor (dB).

Standard:	ISN(Voltage)	Line:	N/A
Test item:	Conducted Emission	Power:	AC 230V/50Hz
Model Number:	PM-3033	Temp.(°C)/Hum.(%RH):	26(°C)/60%RH
Mode:	Mode 1 (ISN 1G)	Date:	2015/09/10
		Test By:	Frank Lin
Description:			

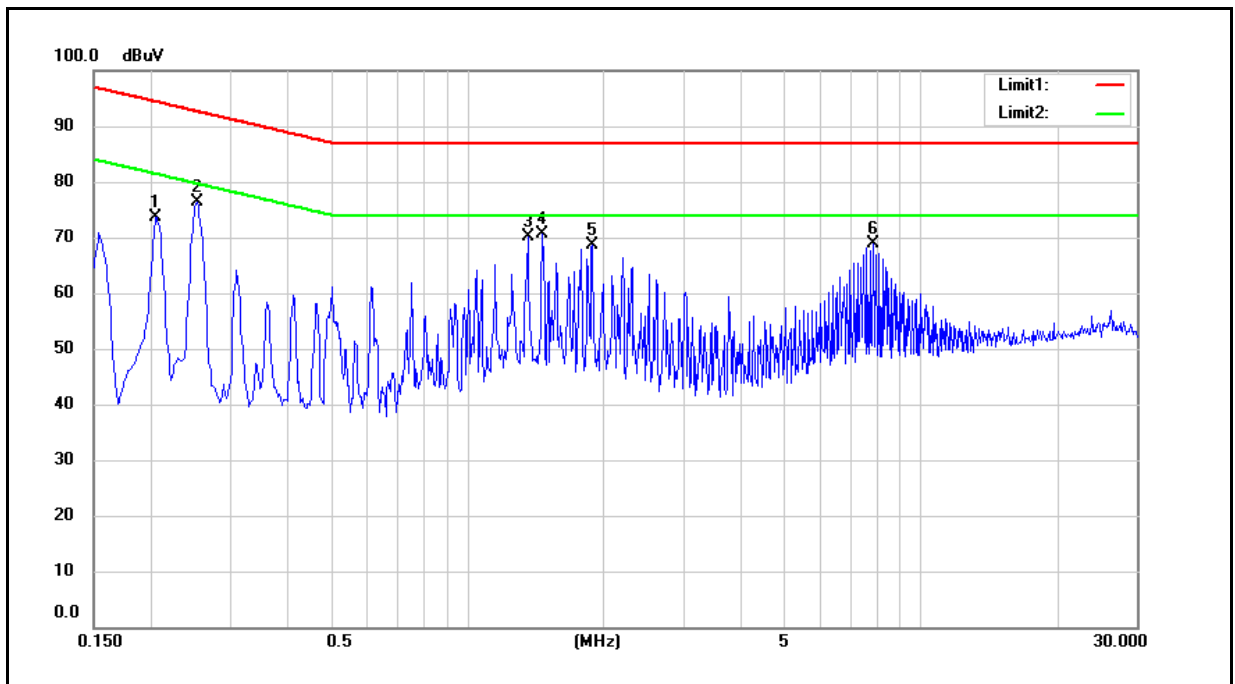

No.	Frequency (MHz)	QP reading (dBuV)	AVG reading (dBuV)	Correction factor (dB)	QP result (dBuV)	AVG result (dBuV)	QP limit (dBuV)	AVG limit (dBuV)	QP margin (dB)	AVG margin (dB)	Remark
1	0.2060	62.55	60.91	10.28	72.83	71.19	94.37	81.37	-21.54	-10.18	Pass
2	0.2540	64.08	63.16	10.25	74.33	73.41	92.63	79.63	-18.30	-6.22	Pass
3	1.3660	60.19	59.29	9.95	70.14	69.24	87.00	74.00	-16.86	-4.76	Pass
4	1.4700	60.52	59.93	9.96	70.48	69.89	87.00	74.00	-16.52	-4.11	Pass
5	1.8900	58.83	57.89	9.95	68.78	67.84	87.00	74.00	-18.22	-6.16	Pass
6	7.8780	57.61	56.31	9.99	67.60	66.30	87.00	74.00	-19.40	-7.70	Pass

Note: 1. Result (dBuV) = Correction factor (dB) + Reading(dBuV).

2. Correction factor (dB) = Cable loss (dB) + L.I.S.N. factor (dB).

4.1.6. Test Photograph

Test Mode: Mode 1

Description: Front View of Conducted Test



Test Mode: Mode 1

Description: Back View of Conducted Test

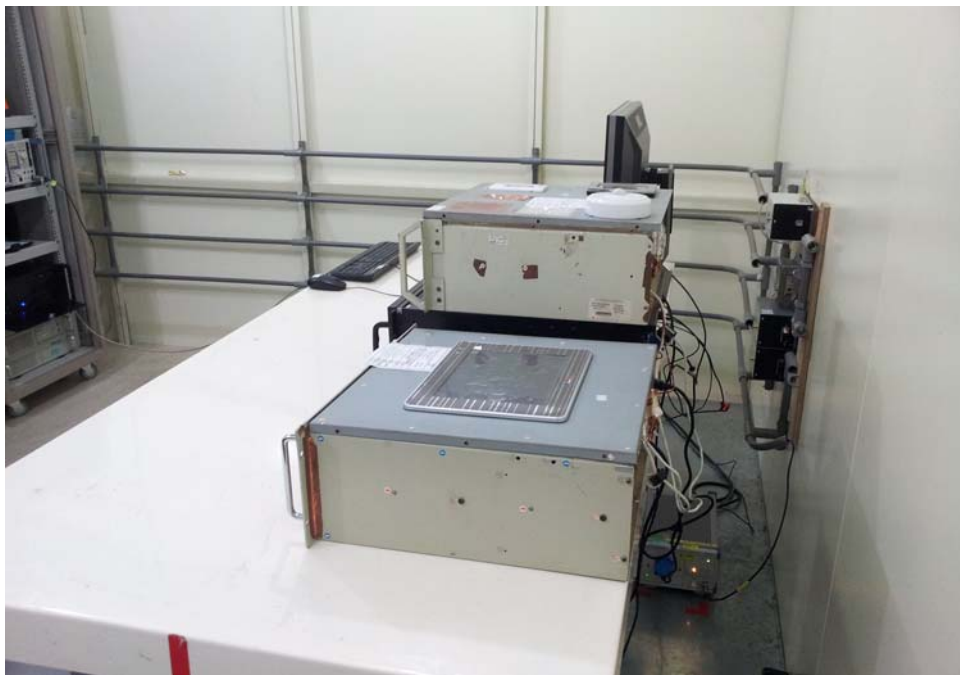

## 4.2. Radiated Emission Measurement

### 4.2.1. Limit

Frequency (MHz)	dBuV/m (Distance 10m)	
	Class A	Class B
30 ~ 230	40	30
230 ~ 1000	47	37

Note: The lower limit shall apply at the transition frequencies.

### 4.2.2. Test Instruments

10 Meter Chamber					
Equipment	Manufacturer	Model Number	Serial Number	Cal. Date	Cal. Period
Pre Amplifier	Agilent	8447D	2944A11120	01/09/2015	1 year
Pre Amplifier	Agilent	8447D	2944A11119	01/09/2015	1 year
Test Receiver	R&S	ESCI	100722	10/24/2014	1 year
Test Receiver	R&S	ESCI	101000	10/24/2014	1 year
Broadband Antenna	SCHWARZBECK MESS-ELEKTRONIK	VULB 9160	9160-3268	06/04/2015	1 year
Broadband Antenna	SCHWARZBECK MESS-ELEKTRONIK	VULB 9160	9160-3273	11/29/2014	1 year
Test Site	ATL	TE06	TE06	01/06/2015	1 year

Note: N.C.R. = No Calibration Request.

#### 4.2.3. Setup

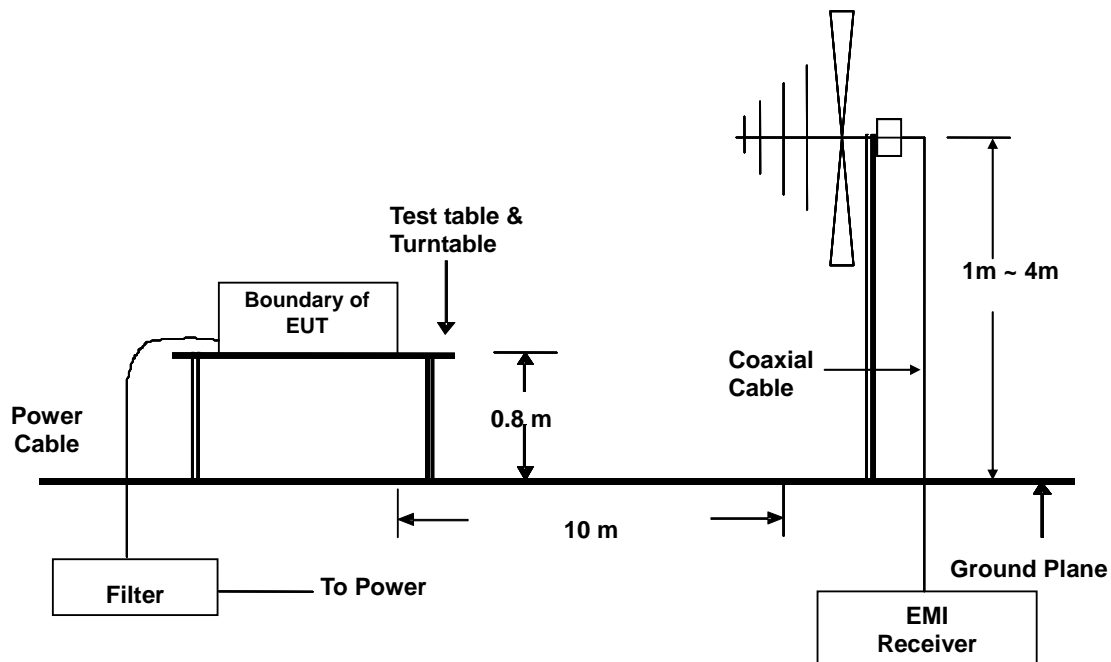

#### 4.2.4. Test Procedure

##### Procedure of Preliminary Test

The equipment was set up as per the test configuration to simulate typical usage per the user's manual. When the EUT is a tabletop system, a wooden turntable with a height of 0.8 meters is used which is placed on the ground plane. When the EUT is floor-standing equipment, it is placed on the ground plane that has a 15 mm non-conductive covering to insulate the EUT from the ground plane.

Support equipment, if needed, was placed as per EN 55011.

All I/O cables were positioned to simulate typical usage as per EN 55011.

The EUT received AC power source, 230VAC/50Hz, from the outlet socket under the turntable. All support equipment received power from another socket under the turntable.

The antenna was placed at 10 meter away from the EUT as stated in EN 55011. The antenna connected to the Spectrum Analyzer via a cable and at times a pre-amplifier would be used.

The Analyzer / Receiver quickly scanned from 30MHz to 1000MHz. The EUT test program was started. Emissions were scanned and measured rotating the EUT to 360 degrees and positioning the antenna 1 to 4 meters above the ground plane, in both the vertical and the horizontal polarization, to maximize the emission reading level.

The test mode(s) described in Item 3.2 were scanned during the preliminary test:

After the preliminary scan, we found the test mode described in Item 3.2 producing the highest emission level.

The worst configuration of EUT and cable, antenna position, polarization and turntable position of the above highest emission level were recorded for the final test.



**Procedure of Final Test**

EUT and support equipment were set up on the turntable as per the configuration with highest emission level in the preliminary test.

The Analyzer / Receiver scanned from 30MHz to 1000MHz. Emissions were scanned and measured rotating the EUT to 360 degrees, varying cable placement and positioning the antenna 1 to 4 meters above the ground plane, in both the vertical and the horizontal polarization, to maximize the emission reading level.

Recorded at least the six highest emissions. Emission frequency, amplitude, antenna position, polarization and turntable position were recorded into a computer in which correction factors were used to calculate the emission level and compare reading to the applicable limit and only Q.P. reading is presented.

The test data of the worst-case condition(s) was recorded.

**4.2.5. Test Result**

Standard:	EN 55011	Test Distance:	10m
Test item:	Radiated Emission	Power:	AC 230V/50Hz
Model Number:	PM-3033	Temp.(°C)/Hum.(%RH):	26(°C)/60%RH
Mode:	Mode 1	Date:	2015/09/09
Ant.Polar.:	Horizontal	Test By:	Frank Lin

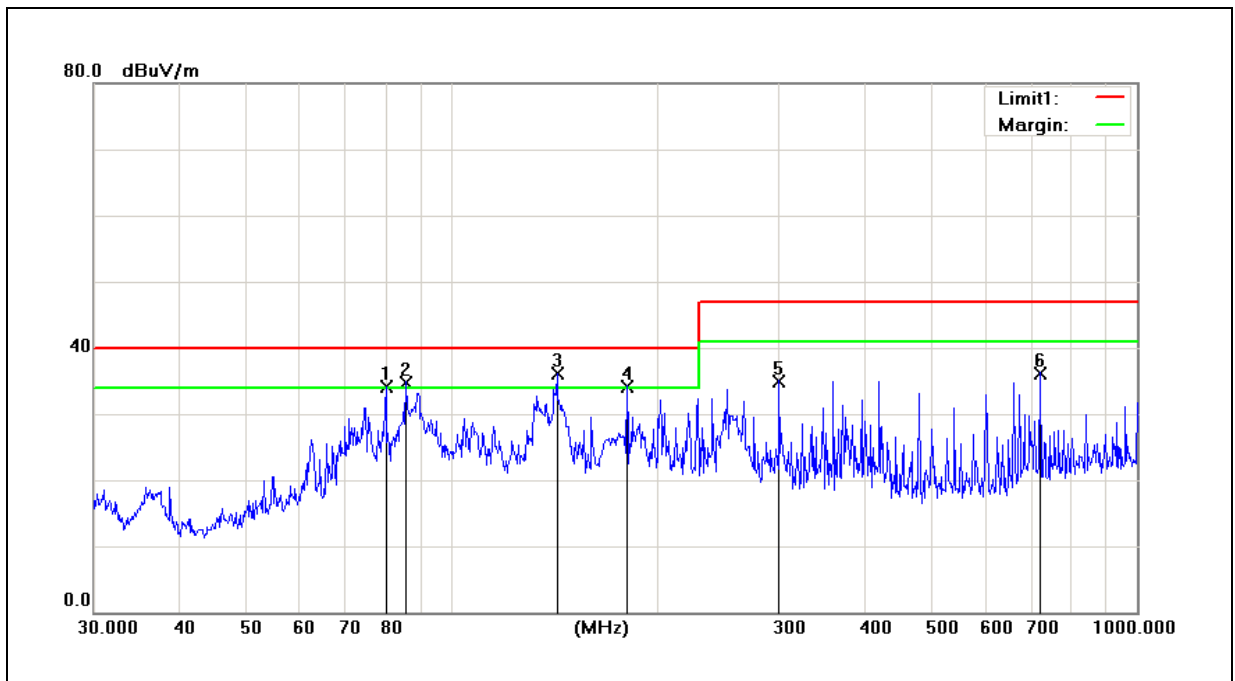

No.	Frequency (MHz)	Reading (dBuV)	Correct Factor(dB/m)	Result (dBuV/m)	Limit (dBuV/m)	Margin (dB)	Height (cm)	Degree (°)	Remark
1	80.0806	53.64	-19.54	34.10	40.00	-5.90	400	14	QP
2	85.5977	54.71	-19.91	34.80	40.00	-5.20	300	98	QP
3	142.3240	50.58	-14.48	36.10	40.00	-3.90	200	59	QP
4	180.0165	49.65	-15.45	34.20	40.00	-5.80	400	100	QP
5	300.3672	48.32	-13.32	35.00	47.00	-12.00	300	257	QP
6	721.7260	42.57	-6.37	36.20	47.00	-10.80	200	100	QP

Note: 1. Result (dBuV) = Correction factor (dB) + Reading(dBuV).

2. Correction factor (dB/m) = Antenna Factor (dB/m) + Cable loss (dB) – Pre-Amplifier gain (dB).

Standard:	EN 55011	Test Distance:	10m
Test item:	Radiated Emission	Power:	AC 230V/50Hz
Model Number:	PM-3033	Temp.(°C)/Hum.(%RH):	26(°C)/60%RH
Mode:	Mode 1	Date:	2015/09/09
Ant.Polar.:	Vertical	Test By:	Frank Lin

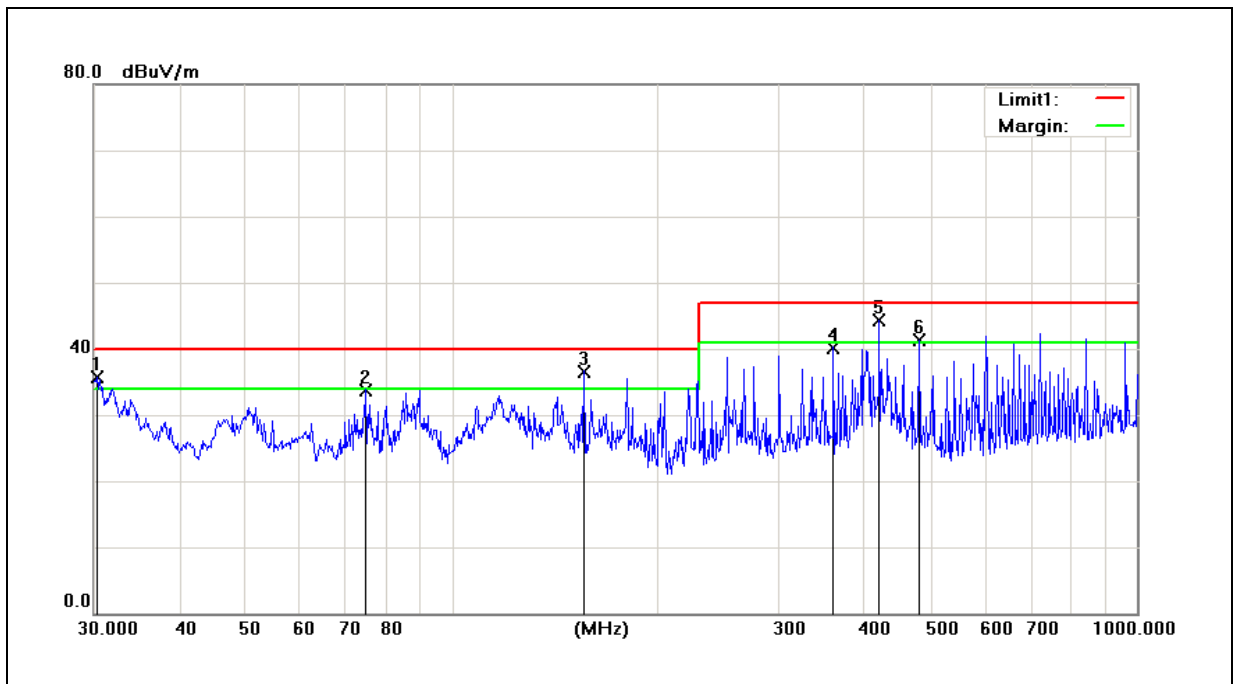

No.	Frequency (MHz)	Reading (dBuV)	Correct Factor(dB/m)	Result (dBuV/m)	Limit (dBuV/m)	Margin (dB)	Height (cm)	Degree (°)	Remark
1	30.3170	51.01	-15.31	35.70	40.00	-4.30	100	333	QP
2	74.9191	50.47	-16.67	33.80	40.00	-6.20	200	214	QP
3	155.9100	48.21	-11.61	36.60	40.00	-3.40	100	238	QP
4	360.4476	48.47	-8.27	40.20	47.00	-6.80	100	270	QP
5	420.5803	50.98	-6.68	44.30	47.00	-2.70	200	155	QP
6	480.5276	46.42	-5.12	41.30	47.00	-5.70	100	10	QP

Note: 1. Result (dBuV) = Correction factor (dB) + Reading(dBuV).

2. Correction factor (dB/m) = Antenna Factor (dB/m) + Cable loss (dB) – Pre-Amplifier gain (dB).

4.2.6. Test Photograph

Test Mode: Mode 1

Description: Front View of Radiated Emission Test \_ Below 1GHz



Test Mode: Mode 1

Description: Back View of Radiated Emission Test \_ Below 1GHz



### 4.3. Harmonics Current Measurement

#### 4.3.1. Limit

##### Limits of Class A Harmonics Currents

Harmonics Order n	Maximum Permissible harmonic current (A)	Harmonics Order n	Maximum Permissible harmonic current (A)
Odd harmonics		Even harmonics	
3	2.30	2	1.08
5	1.14	4	0.43
7	0.77	6	0.30
9	0.40	8 ≤ n ≤ 40	0.23 * 8/n
11	0.33		
13	0.21		
15 ≤ n ≤ 39	0.15 * 15/n		

##### Limits of Class B Harmonics Currents

For Class B equipment, the harmonic of the input current shall not exceed the maximum permissible values given in table which is the limit of Class A multiplied by a factor of 1.5.

##### Limits of Class C Harmonics Currents

Harmonics Order n	Maximum Permissible harmonic current Expressed as a percentage of the input current at the fundamental frequency (%)
2	2
3	30 · λ*
5	10
7	7
9	5
11 ≤ n ≤ 39 (odd harmonics only)	3

\* λ is the circuit power factor

##### Limits of Class D Harmonics Currents

Harmonics Order n	Maximum Permissible harmonic current per watt (mA/W)	Maximum Permissible harmonic current (A)
3	3.4	2.30
5	1.9	1.14
7	1.0	0.77
9	0.5	0.40
11	0.35	0.33
11 ≤ n ≤ 39 (odd harmonics only)	3.85/n	See limit of Class A

**4.3.2. Test Instrument**

Equipment	Manufacturer	Model Number	Serial Number	Cal. Date	Remark
Power Harmonics Analyzers	EMC-Partner AG	HAR1000-1P	171	03/13/2015	(2)
Test Site	ATL	TE08	TE08	N.C.R.	-----

Remark: <sup>(1)</sup> Calibration period 1 year. <sup>(2)</sup> Calibration period 2 years.

NOTE: N.C.R. = No Calibration Request.

**4.3.3. Setup**

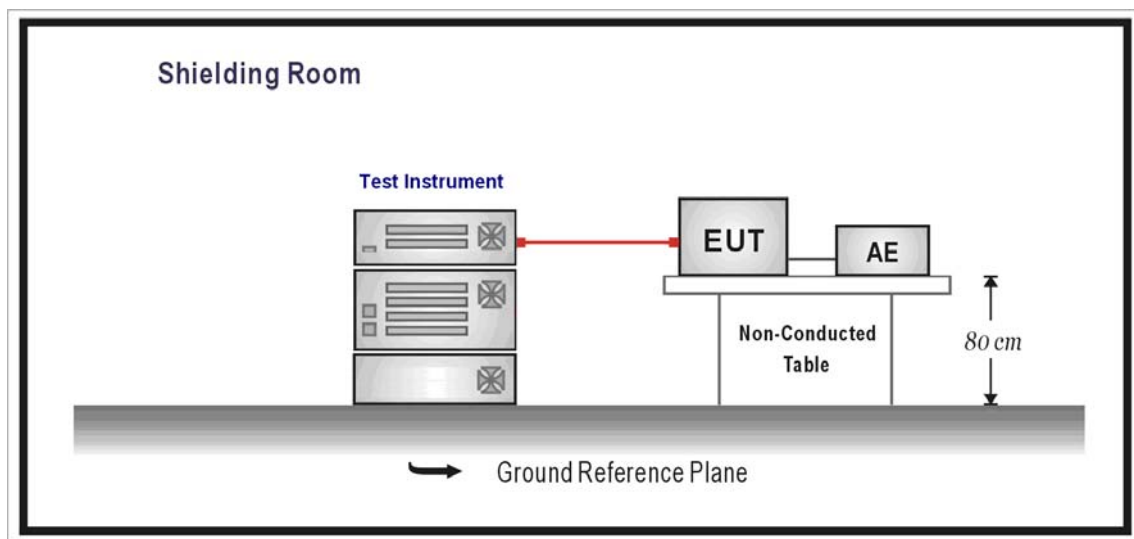

**4.3.4. Test Procedure**

The EUT was placed on the top of a wooden table 0.8 meters above the ground and the EUT is supplied in series with power analyzer from a power source having the same normal voltage and frequency as the rated supply voltage and the equipment under test. And the rated voltage at the supply voltage of EUT of 0.94 times and 1.06 times shall be performed.

A definition of the normal load or of the conditions for adequate heat discharge can usually be found in the EN publication corresponding to the equipment under test.

Equipment may have several separately controlled circuits. Each circuit is considered as a single piece of equipment if it can be operated independently and separately from the other circuits.

**4.3.5. Test Result**

Model Number	PM-3033		
Test Item	Power Harmonics		
Test Mode	Mode 1		
Date of Test	2015/09/10	Test Site	TE08

Test Result: Pass

Source qualification: Normal

Current &amp; voltage waveforms

Harmonics and Class A limit line

European Limits

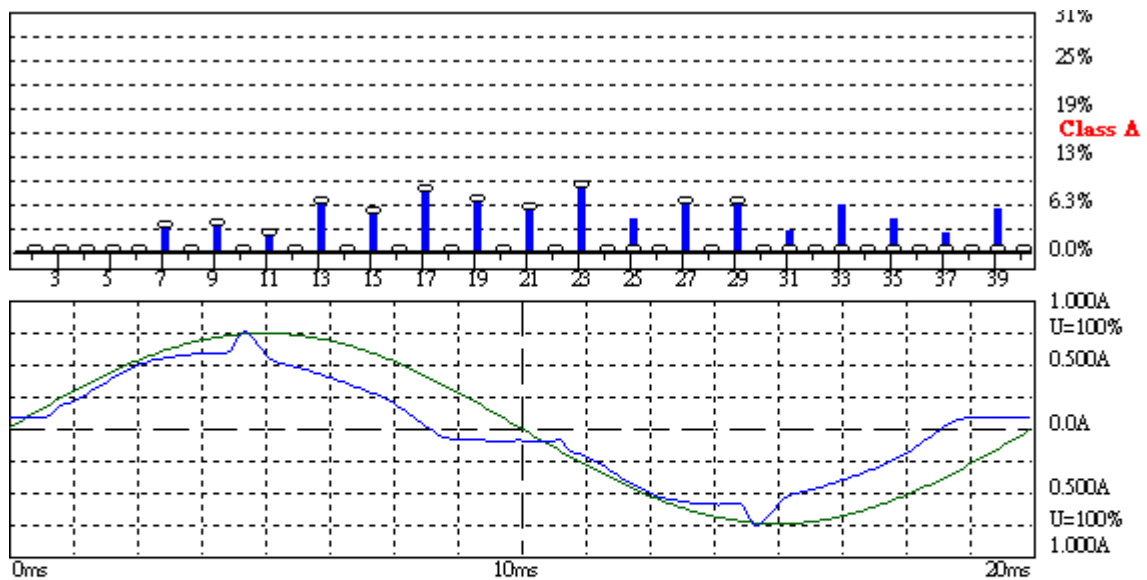
**Harmonic Emission - IEC 61000-3-2 , EN 61000-3-2 , (EN60555-2)**

2015/9/10 PM 08:15:1

$U_{rms} = 229.5 \text{ V}$      $P = 83.74 \text{ W}$      $THC = 0.091 \text{ A}$   
 $I_{rms} = 0.398 \text{ A}$      $pf = 0.929$

Range: 1 A  
 V-nom: 230 V  
 TestTime: 3 min (100%)

15-0775-E

**Test completed, Result: PASSED**

HAR-1000 FMC-Retre

Note 1:

For the following categories of equipment limits are not specified in this edition of the standard.

- Equipment with a rated power of 75 W or less, other than lighting equipment.
- Professional equipment with a total rated power greater than 1 kW;
- Symmetrically controlled heating elements with a rated power less than or equal to 200 W;
- Independent dimmers for incandescent lamps with a rated power less than or equal to 1 kW.

Urms = 229.5V	Freq = 49.922	Range: 1 A
Irms = 0.393A	Ipk = 0.770A	cf = 1.960
P = 83.74W	S = 90.10VA	pf = 0.929
THDi = 24.0 %	THDu = 0.10 %	Class A
Test - Time :	3min ( 100 %)	
Test completed, Result: PASSED		

Order	Freq. [Hz]	Iavg [A]	Irms [A]	Imax [A]	Limit [A]	Status
1	50	0.3777	0.3805	0.3838		PASS
2	100	0.0000	0.0018	0.0019	1.0800	PASS
3	150	0.0786	0.0786	0.0803	2.3000	PASS
4	200	0.0000	0.0004	0.0004	0.4300	PASS
5	250	0.0260	0.0261	0.0262	1.1400	PASS
6	300	0.0000	0.0009	0.0009	0.3000	PASS
7	350	0.0238	0.0236	0.0239	0.7700	PASS
8	400	0.0000	0.0002	0.0004	0.2300	PASS
9	450	0.0141	0.0143	0.0143	0.4000	PASS
10	500	0.0000	0.0003	0.0004	0.1840	PASS
11	550	0.0076	0.0076	0.0077	0.3300	PASS
12	600	0.0000	0.0002	0.0003	0.1533	PASS
13	650	0.0136	0.0135	0.0137	0.2100	PASS
14	700	0.0000	0.0001	0.0002	0.1314	PASS
15	750	0.0074	0.0074	0.0074	0.1500	PASS
16	800	0.0000	0.0002	0.0003	0.1150	PASS
17	850	0.0106	0.0106	0.0106	0.1324	PASS
18	900	0.0000	0.0002	0.0002	0.1022	PASS
19	950	0.0078	0.0078	0.0079	0.1184	PASS
20	1000	0.0000	0.0002	0.0002	0.0920	PASS
21	1050	0.0061	0.0061	0.0062	0.1071	PASS
22	1100	0.0000	0.0002	0.0003	0.0836	PASS
23	1150	0.0082	0.0082	0.0082	0.0978	PASS
24	1200	0.0000	0.0002	0.0002	0.0767	PASS
25	1250	0.0000	0.0036	0.0036	0.0900	PASS
26	1300	0.0000	0.0002	0.0002	0.0708	PASS
27	1350	0.0052	0.0052	0.0052	0.0833	PASS
28	1400	0.0000	0.0002	0.0002	0.0657	PASS
29	1450	0.0051	0.0051	0.0051	0.0776	PASS
30	1500	0.0000	0.0002	0.0002	0.0613	PASS
31	1550	0.0000	0.0018	0.0018	0.0726	PASS
32	1600	0.0000	0.0002	0.0002	0.0575	PASS
33	1650	0.0000	0.0040	0.0040	0.0682	PASS
34	1700	0.0000	0.0002	0.0002	0.0541	PASS
35	1750	0.0000	0.0025	0.0026	0.0643	PASS
36	1800	0.0000	0.0002	0.0002	0.0511	PASS
37	1850	0.0000	0.0013	0.0014	0.0608	PASS
38	1900	0.0000	0.0002	0.0003	0.0484	PASS
39	1950	0.0000	0.0031	0.0032	0.0577	PASS
40	2000	0.0000	0.0002	0.0002	0.0460	PASS

- Dynamic limits were applied for this test. The highest harmonics values in the above table may not occur at the same window as the maximum harmonics/limit ratio.
- According to EN61000-3-2 paragraph 7 the note 1 and 2 are valid for all applications having an active input power >75W. Others the result should be pass.



#### 4.3.6. Test Photograph

Test Mode: Mode 1

Description: Front View of Power Harmonics Test



#### 4.4. Voltage Fluctuation and Flicker

##### 4.4.1. Limit

The following limits apply:

- the value of  $P_{st}$  shall not be greater than 1.0;
- the value of  $P_{1t}$  shall not be greater than 0.65;
- the value of  $d(t)$  during a voltage change shall not exceed 3.3 % for more than 500 ms;
- the relative steady-state voltage change,  $d_c$ , shall not exceed 3.3 %;
- the maximum relative voltage change,  $d_{max}$ , shall not exceed;
  - a) 4 % without additional conditions;
  - b) 6 % for equipment which is:
    - switched manually, or
    - switched automatically more frequently than twice per day, and also has either a delayed restart (the delay being not less than a few tens of seconds), or manual restart, after a power supply interruption.

Note: The cycling frequency will be further limited by the  $P_{st}$  and  $P_{1t}$  limit.

For example: a  $d_{max}$  of 6% producing a rectangular voltage change characteristic twice per hour will give a  $P_{1t}$  of about 0.65.

- c) 7 % for equipment which is:
  - attended whilst in use (for example: hair dryers, vacuum cleaners, kitchen equipment such as mixers, garden equipment such as lawn mowers, portable tools such as electric drills), or
  - switched on automatically, or is intended to be switched on manually, no more than twice per day, and also has either a delayed restart (the delay being not less than a few tens of seconds) or manual restart, after a power supply interruption.

$P_{st}$  and  $P_{1t}$  requirements shall not be applied to voltage changes caused by manual switching.

##### 4.4.2. Test Instrument

Equipment	Manufacturer	Model Number	Serial Number	Cal. Date	Cal. Period
Power Harmonics Analyzers	EMC-Partner AG	HAR1000-1P	171	03/13/2015	2 year
Test Site	ATL	TE05	TE05	N.C.R.	----

Note: N.C.R. = No Calibration Request.

#### 4.4.3. Setup

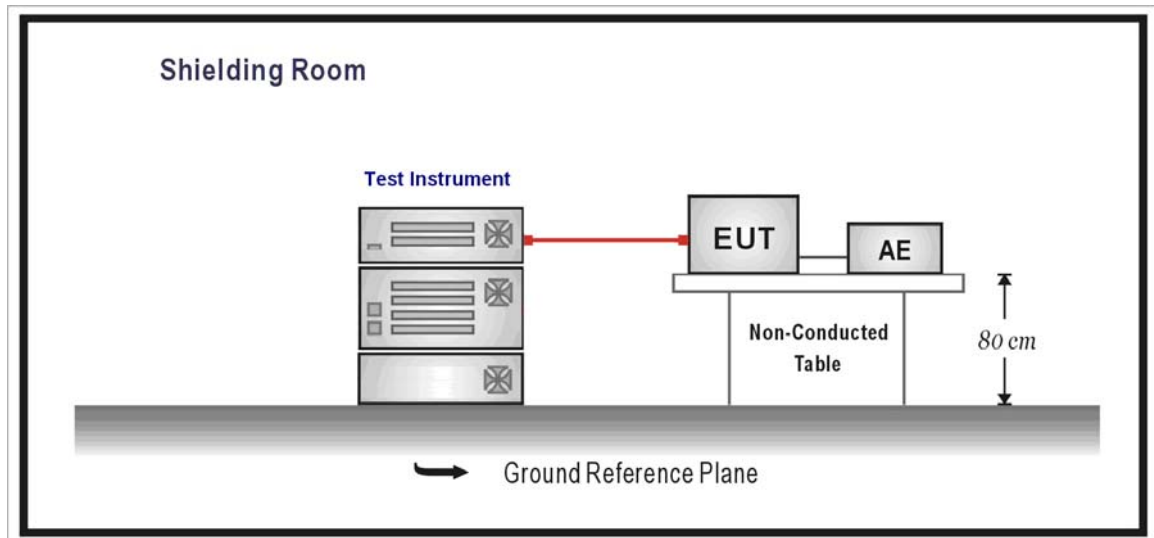

#### 4.4.4. Test Procedure

The EUT was placed on the top of a wooden table 0.8 meters above the ground and operated to produce the most unfavorable sequence of voltage changes under normal operating conditions.

During the flick measurement, the measure time shall include that part of whole operation cycle in which the EUT produce the most unfavorable sequence of voltage changes. The observation period for short-term flicker indicator is 10 minutes and the observation period for long-term flicker indicator is 2 hours.

**4.4.5. Test Result**

Model Number	PM-3033		
Test Item	Flicker		
Test Mode	Mode 1		
Date of Test	2015/09/09	Test Site	TE05

Test Result: Pass Status: Test Completed

Plt and limit line

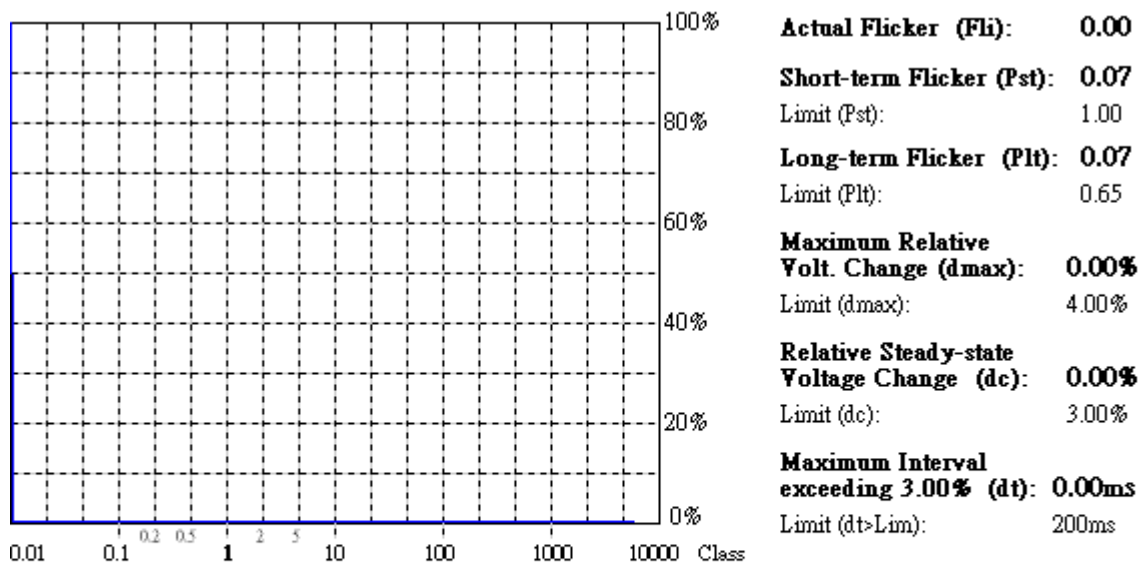
**Flicker Emission - IEC 61000-3-3 , EN 61000-3-3**

 Urms = 229.5 V P = 83.12 W  
 Irms = 0.391 A pf = 0.927

15-0775-E

**Test completed, Result: PASSED**

2015/9/10 PM 08:54:4

 Range: 1 A  
 V-nom: 230 V  
 TestTime: 10 min (100%)

HAR-1000 FMC-Retre

 Urms = 229.5V Freq = 49.922 Range: 1 A  
 Irms = 0.391A Ipk = 0.777A cf = 1.989  
 P = 83.12W S = 89.66VA pf = 0.927  
 Test - Time : 1 x 10min = 10min ( 100 %)

LIN (Line Impedance Network) : L: 0.24ohm +j0.15ohm N: 0.16ohm +j0.10ohm

 Limits : Plt : 0.65 Pst : 1.00  
 dmax : 4.00 % dc : 3.00 %  
 dtLim: 3.00 % dt>Lim: 200ms

Test completed, Result: PASSED

#### 4.4.6. Test Photograph

Test Mode: Mode 1

Description: Front View of Flicker Test



## 5 Immunity Test

### 5.1. Electrostatic Discharge (ESD)

#### 5.1.1. Test Specification

EN 61000-4-2			
Environmental Phenomena	Units	Test Specification	Performance Criterion
Enclosure Port			
Electrostatic Discharge	kV (Charge Voltage)	±2,4,8 Air Discharge ±2,4 Contact Discharge	B

#### 5.1.2. Test Instrument

Equipment	Manufacturer	Model Number	Serial Number	Cal. Date	Cal. Period
Discharge Gun	Noiseken	ESS-2002	ESS05Y4736	03/14/2014	1 year
0.8m Height Wooden Table	N/A	N/A	N/A	N.C.R.	-----
Test Site	ATL	TE04	TE04	N.C.R.	-----

Note: N.C.R. = No Calibration Request.

#### 5.1.3. Setup

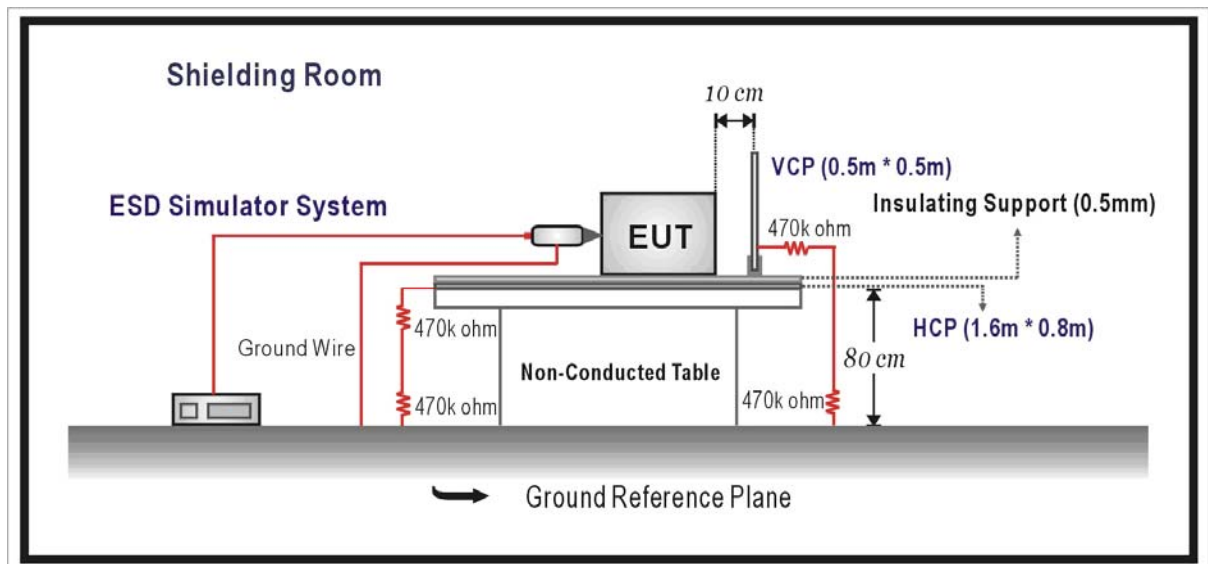

#### 5.1.4. Test Procedure

The discharges shall be applied in two ways:

a) Contact discharges to the conductive surfaces and coupling planes:

The EUT shall be exposed to at least 200 discharges, 100 each at negative and positive polarity, at a minimum of four test points. One of the test points shall be subjected to at least 50 indirect discharges to the center of the front edge of the Horizontal Coupling Plane (HCP). The remaining three test points shall each receive at least 50 direct contact discharges. If no direct contact test point be available, then at least 200 indirect discharges shall be applied in the indirect mode. Test shall be performed at a maximum repetition rate of one discharge per second.

b) Air discharges at slots and apertures and insulating surfaces:

On those parts of the EUT where it is not possible to perform contact discharge testing, the equipment should be investigated to identify user accessible points where breakdown may occur. Such points are tested using the air discharge method. This investigation should be restricted to those area normally handled by the user. A minimum of 10 single air discharges shall be applied to the selected test point for each such area.

The basic test procedure was in accordance with EN 61000-4-2:

- a) The EUT was located 0.1 m minimum from all side of the HCP (dimensions 1.6m x 0.8m).
- b) The support units were located another table 30 cm away from the EUT, but direct support unit was/were located at same location as EUT on the HCP and keep at a distance of 10 cm with EUT.
- c) The time interval between two successive single discharges was at least 1 second.
- d) Contact discharges were applied to the non-insulating coating, with the pointed tip of the generator penetrating the coating and contacting the conducting substrate.
- e) Air discharges were applied with the round discharge tip of the discharge electrode approaching the EUT as fast as possible (without causing mechanical damage) to touch the EUT. After each discharge, the ESD generator was removed from the EUT and re-triggered for a new single discharge. The test was repeated until all discharges were complete.
- f) At least ten single discharges (in the most sensitive polarity) were applied at the front edge of each HCP opposite the center point of each unit of the EUT and 0.1 meters from the front of the EUT. The long axis of the discharge electrode was in the plane of the HCP and perpendicular to its front edge during the discharge.
- g) At least ten single discharges (in the most sensitive polarity) were applied to the center of one vertical edge of the Vertical Coupling Plane (VCP) in sufficiently different positions that the four faces of the EUT were completely illuminated. The VCP (dimensions 0.5m x 0.5m) was placed vertically to and 0.1 meters from the EUT.

**5.1.5. Test Result**

Model Number	PM-3033		
Test Item	Electrostatic Discharge		
Test Mode	Mode 1		
Date of Test	2015/09/10	Test Site	TE04

Air Discharge												
Test Points	Test Levels						Results					
	± 2 kV	Performance Criterion		± 4 kV	Performance Criterion		± 8 kV	Performance Criterion		Pass	Fail	Observation
Touch panel	<input checked="" type="checkbox"/>	<input type="checkbox"/> A	<input checked="" type="checkbox"/> B	<input checked="" type="checkbox"/>	<input type="checkbox"/> A	<input checked="" type="checkbox"/> B	<input checked="" type="checkbox"/>	<input type="checkbox"/> A	<input checked="" type="checkbox"/> B	<input checked="" type="checkbox"/>	<input type="checkbox"/>	Note2
LAN Port	<input checked="" type="checkbox"/>	<input type="checkbox"/> A	<input checked="" type="checkbox"/> B	<input checked="" type="checkbox"/>	<input type="checkbox"/> A	<input checked="" type="checkbox"/> B	<input checked="" type="checkbox"/>	<input type="checkbox"/> A	<input checked="" type="checkbox"/> B	<input checked="" type="checkbox"/>	<input type="checkbox"/>	Note2
Case	<input checked="" type="checkbox"/>	<input checked="" type="checkbox"/> A	<input type="checkbox"/> B	<input checked="" type="checkbox"/>	<input type="checkbox"/> A	<input checked="" type="checkbox"/> B	<input checked="" type="checkbox"/>	<input type="checkbox"/> A	<input checked="" type="checkbox"/> B	<input checked="" type="checkbox"/>	<input type="checkbox"/>	Note1

Contact Discharge												
Test Points	Test Levels						Results					
	± 2 kV	Performance Criterion		± 4 kV	Performance Criterion		± 8 kV	Performance Criterion		Pass	Fail	Observation
Case	<input checked="" type="checkbox"/>	<input checked="" type="checkbox"/> A	<input type="checkbox"/> B	<input checked="" type="checkbox"/>	<input type="checkbox"/> A	<input checked="" type="checkbox"/> B	<input type="checkbox"/>	<input type="checkbox"/> A	<input type="checkbox"/> B	<input checked="" type="checkbox"/>	<input type="checkbox"/>	Note3
Screws	<input checked="" type="checkbox"/>	<input checked="" type="checkbox"/> A	<input type="checkbox"/> B	<input checked="" type="checkbox"/>	<input type="checkbox"/> A	<input checked="" type="checkbox"/> B	<input type="checkbox"/>	<input type="checkbox"/> A	<input type="checkbox"/> B	<input checked="" type="checkbox"/>	<input type="checkbox"/>	Note2

For the tested points to EUT, please refer to attached page.  
 (Blue arrow mark for Air Discharge and red arrow mark for Contact Discharge)

Discharge To Horizontal Coupling Plane									
Side of EUT	Test Levels				Results				
	± 2 kV	± 4 kV	± 6 kV	± 8 kV	Pass	Fail	Performance Criterion		Observation
Front	<input checked="" type="checkbox"/>	<input checked="" type="checkbox"/>	<input type="checkbox"/>	<input type="checkbox"/>	<input checked="" type="checkbox"/>	<input type="checkbox"/>	<input checked="" type="checkbox"/> A	<input type="checkbox"/> B	Note1
Back	<input checked="" type="checkbox"/>	<input checked="" type="checkbox"/>	<input type="checkbox"/>	<input type="checkbox"/>	<input checked="" type="checkbox"/>	<input type="checkbox"/>	<input checked="" type="checkbox"/> A	<input type="checkbox"/> B	Note1
Left	<input checked="" type="checkbox"/>	<input checked="" type="checkbox"/>	<input type="checkbox"/>	<input type="checkbox"/>	<input checked="" type="checkbox"/>	<input type="checkbox"/>	<input checked="" type="checkbox"/> A	<input type="checkbox"/> B	Note1
Right	<input checked="" type="checkbox"/>	<input checked="" type="checkbox"/>	<input type="checkbox"/>	<input type="checkbox"/>	<input checked="" type="checkbox"/>	<input type="checkbox"/>	<input checked="" type="checkbox"/> A	<input type="checkbox"/> B	Note1

Discharge To Vertical Coupling Plane									
Side of EUT	Test Levels				Results				
	± 2 kV	± 4 kV	± 6 kV	± 8 kV	Pass	Fail	Performance Criterion		Observation
Front	<input checked="" type="checkbox"/>	<input checked="" type="checkbox"/>	<input type="checkbox"/>	<input type="checkbox"/>	<input checked="" type="checkbox"/>	<input type="checkbox"/>	<input checked="" type="checkbox"/> A	<input type="checkbox"/> B	Note1
Back	<input checked="" type="checkbox"/>	<input checked="" type="checkbox"/>	<input type="checkbox"/>	<input type="checkbox"/>	<input checked="" type="checkbox"/>	<input type="checkbox"/>	<input checked="" type="checkbox"/> A	<input type="checkbox"/> B	Note1
Left	<input checked="" type="checkbox"/>	<input checked="" type="checkbox"/>	<input type="checkbox"/>	<input type="checkbox"/>	<input checked="" type="checkbox"/>	<input type="checkbox"/>	<input checked="" type="checkbox"/> A	<input type="checkbox"/> B	Note1
Right	<input checked="" type="checkbox"/>	<input checked="" type="checkbox"/>	<input type="checkbox"/>	<input type="checkbox"/>	<input checked="" type="checkbox"/>	<input type="checkbox"/>	<input checked="" type="checkbox"/> A	<input type="checkbox"/> B	Note1

Note 1: Criterion A: There was no change compared with initial operation during the test.

Criterion B: Display temporary loss of function and can be self-recovery

Note 2: Criterion B: The panel display function loss and self-recovery function.

Keyboard and mouse will temporarily lose function, and self-recovery function.

Note 3: Criterion B: The display screen shaking. and can be self-recovery

The panel display function loss and self-recovery function.

Keyboard and mouse will temporarily lose function, and self-recovery function.



5.1.6. Test Photograph

Test Mode: Mode 1

Description: Front View of ESD Test



Test Mode: Mode 1

Description: Close View of ESD Test



Test Mode: Mode 1  
 Description: Close View of ESD Test



Test Mode: Mode 1  
 Description: Close View of ESD Test



Test Mode: Mode 1

Description: Close View of ESD Test



Test Mode: Mode 1

Description: Close View of ESD Test



Test Mode: Mode 1

Description: Close View of ESD Test

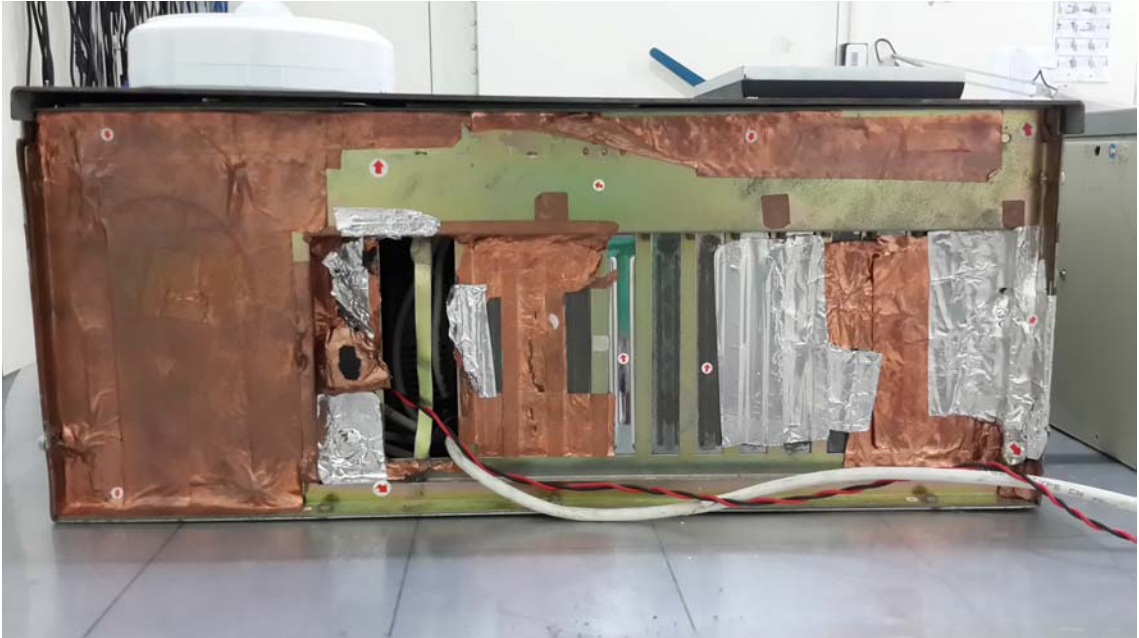

Test Mode: Mode 1

Description: Close View of ESD Test





Test Mode: Mode 1

Description: Close View of ESD Test



Test Mode: Mode 1

Description: Close View of ESD Test



Test Mode: Mode 1

Description: Close View of ESD Test

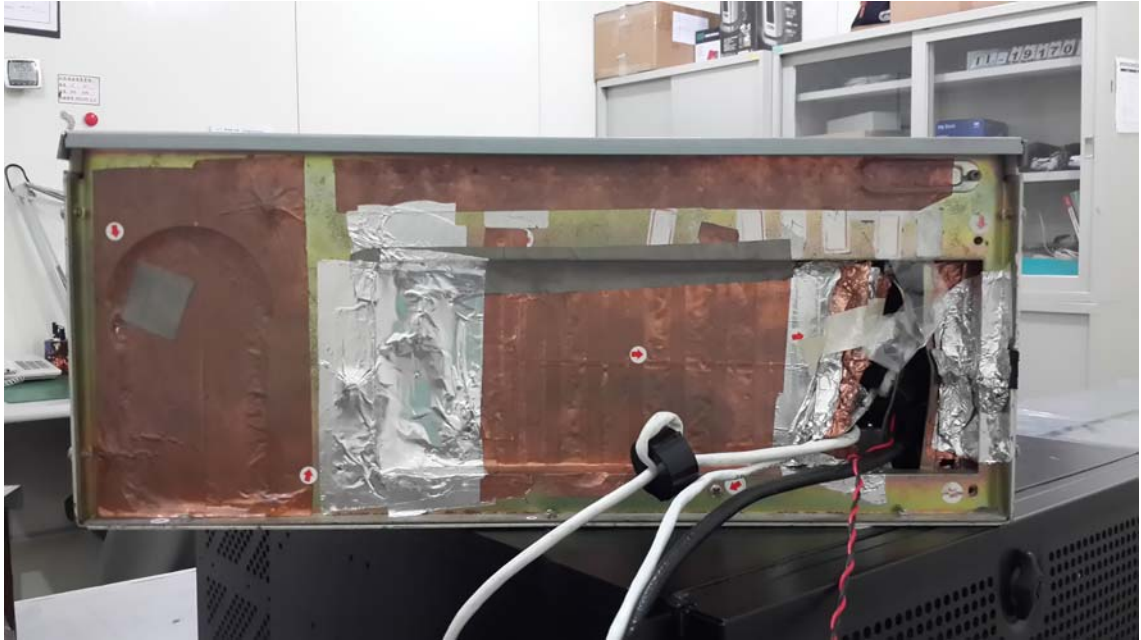

Test Mode: Mode 1

Description: Close View of ESD Test



Test Mode: Mode 1

Description: Close View of ESD Test



Test Mode: Mode 1

Description: Close View of ESD Test



Test Mode: Mode 1

Description: Close View of ESD Test





## 5.2. Radiated Electromagnetic Field (RS)

### 5.2.1. Test Specification

EN 61000-4-3			
Environmental Phenomena	Units	Test Specification	Performance Criterion
Enclosure Port			
Test Frequency Range	MHz	80-1000 1400-2000 2000-2700	A
RF Electromagnetic Field	V/m(Un-modulated, rms)	10 3 1	
Amplitude Modulated	% AM (1kHz)	80	
Test Distance	m	3	
Antenna Height	m	1.5	

EUT tested in accordance with the specifications given by the standard of EN 61000-4-3.

Step : 1%

Step time : 3 Second

### 5.2.2. Test Instrument

Equipment	Manufacturer	Model Number	Serial Number	Cal. Date	Cal. Period
SMB 100A SIGNAL GENERATOR	R&S	SMB100A	100724	03/11/2015	2 year
NRP-Z91 POWER SENSOR	R&S	NRP-Z91	100611	07/24/2015	1 year
NRP-Z91 POWER SENSOR	R&S	NRP-Z91	100612	07/24/2015	1 year
NRP POWER METER	R&S	NRP	101591	07/17/2015	1 year
Solid State Power Amplifier	BONN ELEKTRONIK	BLWA 0830-160/100/40D	87050	N.C.R.	----
Signal Generator Module	R&S	SM300 Module	102209	N.C.R.	----
Broad-Band Horn Antenna	Schwarzbeck Mess-Elektronik	BBHA 9120	BBHA 9120 E388	N.C.R.	----
Test Site	ATL	TE07	888009	N.C.R.	----

Note: N.C.R. = No Calibration Request.

### 5.2.3. Setup

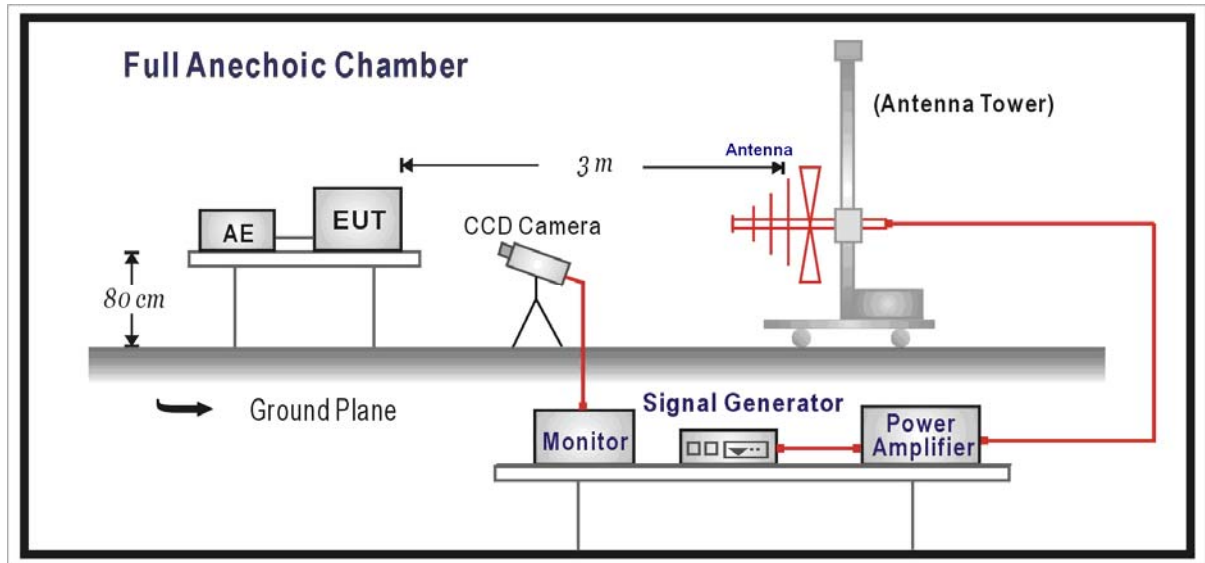

### 5.2.4. Test Procedure

The test procedure was in accordance with EN 61000-4-3

- a) The testing was performed in a fully anechoic chamber. The transmit antenna was located at a distance of 3 meters from the EUT.
- b) The frequency range is swept from 80 MHz to 1000 MHz, with the signal 80% amplitude modulated with a 1kHz sine-wave. The rate of sweep did not exceed  $1.5 \times 10^{-3}$  decade/s, where the frequency range is swept incrementally, the step size was 1% of preceding frequency value.
- c) The dwell time at each frequency shall be not less than the time necessary for the EUT to be able to respond.
- d) The test was performed with the EUT exposed to both vertically and horizontally polarized fields on each of the four sides.

**5.2.5. Test Result**

Model Number	PM-3033				
Test Item	Radiated Susceptibility				
Test Mode	Mode 1				
Date of Test	2015/09/11			Test Site	TE07
Frequency (MHz)	Polarity	Azimuth	Field Strength (V/m)	Performance Criterion	Result
80 ~ 1000	H / V	0	10	<input checked="" type="checkbox"/> A <input type="checkbox"/> B	PASS
80 ~ 1000	H / V	90	10	<input checked="" type="checkbox"/> A <input type="checkbox"/> B	PASS
80 ~ 1000	H / V	180	10	<input checked="" type="checkbox"/> A <input type="checkbox"/> B	PASS
80 ~ 1000	H / V	270	10	<input checked="" type="checkbox"/> A <input type="checkbox"/> B	PASS
1400 ~ 2000	H / V	0	3	<input checked="" type="checkbox"/> A <input type="checkbox"/> B	PASS
1400 ~ 2000	H / V	90	3	<input checked="" type="checkbox"/> A <input type="checkbox"/> B	PASS
1400 ~ 2000	H / V	180	3	<input checked="" type="checkbox"/> A <input type="checkbox"/> B	PASS
1400 ~ 2000	H / V	270	3	<input checked="" type="checkbox"/> A <input type="checkbox"/> B	PASS
2000 ~ 2700	H / V	0	1	<input checked="" type="checkbox"/> A <input type="checkbox"/> B	PASS
2000 ~ 2700	H / V	90	1	<input checked="" type="checkbox"/> A <input type="checkbox"/> B	PASS
2000 ~ 2700	H / V	180	1	<input checked="" type="checkbox"/> A <input type="checkbox"/> B	PASS
2000 ~ 2700	H / V	270	1	<input checked="" type="checkbox"/> A <input type="checkbox"/> B	PASS

Note: The testing performed is from lowest level up to the highest level as required by standard, but only highest level is shown on the report.

Criterion A: Operate as intended during and after the test

Criterion B: Operate as intended after the test

Criterion C: Loss/Error of function

Additional Information

There was no observable degradation in performance.

EUT stopped operation and could / could not be reset by operator at \_\_\_\_\_ V/m at frequency \_\_\_\_\_ MHz.

No false alarms or other malfunctions were observed during or after the test.

**5.2.6. Test Photograph**

Test Mode: Mode 1

Description: Front View of RS Test



### 5.3. Electrical Fast Transient/Burst (EFT)

#### 5.3.1. Test Specification

EN 61000-4-4				
Item	Environmental Phenomena	Units	Test Specification	Performance Criterion
I/O and communication ports				
Fast Transients Common Mode		kV (Peak) Tr/Th ns Rep. Frequency kHz	$\pm 1$ 5/50 5	B
Input DC Power Ports				
Fast Transients Common Mode		kV (Peak) Tr/Th ns Rep. Frequency kHz	$\pm 2$ 5/50 5	B
Input AC Power Ports				
Fast Transients Common Mode		kV (Peak) Tr/Th ns Rep. Frequency kHz	$\pm 2$ 5/50 5	B

#### 5.3.2. Test Instrument

Equipment	Manufacturer	Model Number	Serial Number	Cal. Date	Cal. Period
EMC Immunity Tester	EMC-PARTNER AG	TRANSIENT 2000IN6	952	02/16/2015	1 year
Test Site	ATL	TE08	TE08	N.C.R.	-----

Note: N.C.R. = No Calibration Request.

#### 5.3.3. Setup

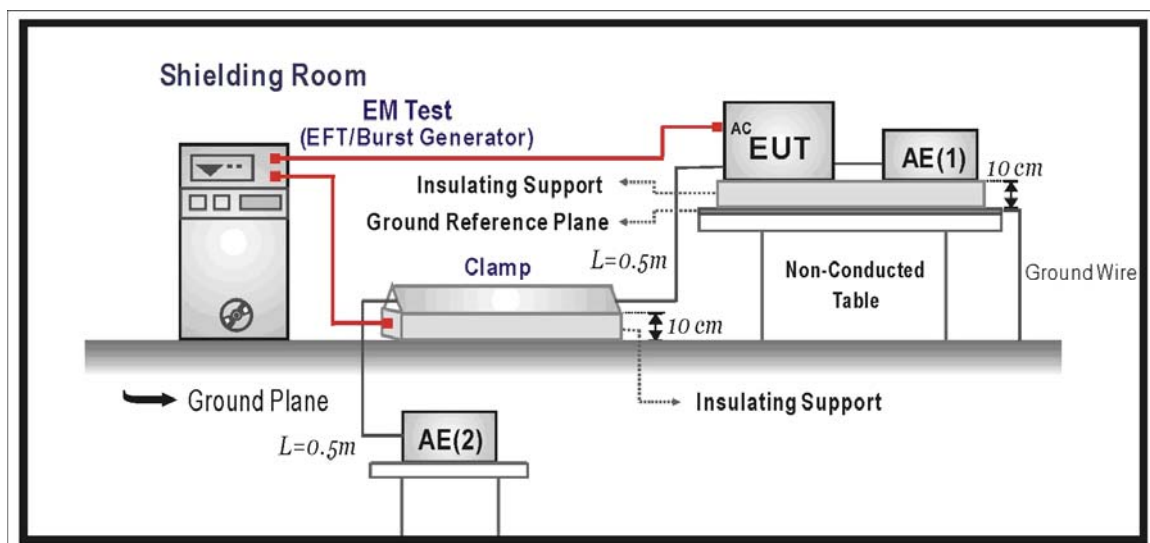

**5.3.4. Test Procedure**

- a) Both positive and negative polarity discharges were applied.
- b) The length of the “hot wire” from the coaxial output of the EFT generator to the terminals on the EUT should not exceed 1 meter.
- c) The duration time of each test sequential was 1 minute.
- d) The transient/burst waveform was in accordance with EN 61000-4-4, 5/50ns.

**5.3.5. Test Result**

Model Number	PM-3033						
Test Item	Electrical Fast Transient/Burst						
Test Mode	Mode 1						
Date of Test	2015/09/11				Test Site	TE08	
Test Point	Polarity	Test Level (kV)	Inject Time (Second)	Inject Method	Performance Criterion	Result	Observation
L	±	2	60	Direct	<input checked="" type="checkbox"/> A <input type="checkbox"/> B	PASS	---
N	±	2	60	Direct	<input checked="" type="checkbox"/> A <input type="checkbox"/> B	PASS	---
PE	±	2	60	Direct	<input checked="" type="checkbox"/> A <input type="checkbox"/> B	PASS	---
L+N	±	2	60	Direct	<input checked="" type="checkbox"/> A <input type="checkbox"/> B	PASS	---
L+PE	±	2	60	Direct	<input checked="" type="checkbox"/> A <input type="checkbox"/> B	PASS	---
N+PE	±	2	60	Direct	<input checked="" type="checkbox"/> A <input type="checkbox"/> B	PASS	---
L+N+PE	±	2	60	Direct	<input checked="" type="checkbox"/> A <input type="checkbox"/> B	PASS	---

Note 1: The testing performed is from lowest level up to the highest level as required by standard, but only highest level is shown on the report.

Criterion A: Operate as intended during and after the test

Criterion B: Operate as intended after the test

Criterion C: Loss/Error of function

Additional Information

There was no observable degradation in performance.

EUT stopped operation and could / could not be reset by operator at \_\_\_\_\_ V/m at frequency \_\_\_\_\_ MHz.

No false alarms or other malfunctions were observed during or after the test.

### 5.3.6. Test Photograph

Test Mode: Mode 1

Description: Front View of EFT Test – AC Mains Port



## 5.4. Surge

### 5.4.1. Test Specification

EN 61000-4-5				
Item	Environmental Phenomena	Units	Test Specification	Performance Criterion
Signal Ports and Telecommunication Ports(See 1) and 2) )				
Surges	Line to Line Line to Ground	Tr/Th us kV	1.2/50 (8/20) ± 1 ± 2	B
Input DC Power Ports				
Surges	Line to Line Line to Ground	Tr/Th us kV	1.2/50 (8/20) ± 1 ± 2	B
Input AC Power Ports				
Surges	Line to Line Line to Ground	Tr/Th us kV kV	1.2/50 (8/20) ± 1 ± 2	B

### 5.4.2. Test Instrument

Equipment	Manufacturer	Model Number	Serial Number	Cal. Date	Cal. Period
EMC Immunity Tester	EMC-PARTNER AG	TRANSIENT 2000IN6	952	02/16/2015	1 year
Test Site	ATL	TE08	TE08	N.C.R.	----

Note: N.C.R. = No Calibration Request.

### 5.4.3. Setup

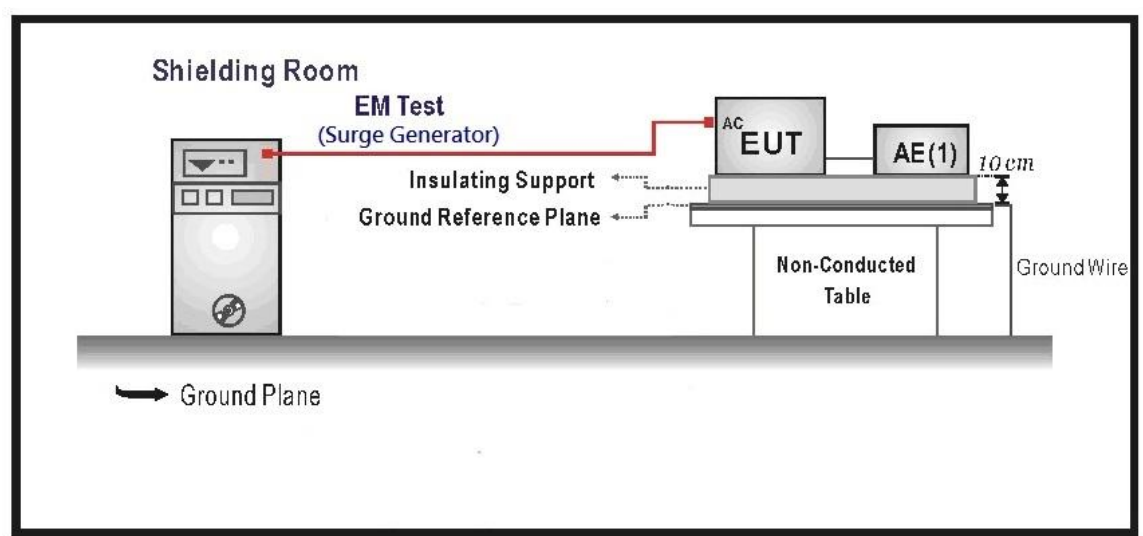



#### 5.4.4. Test Procedure

a) For EUT power supply:

The surge is applied to the EUT power supply terminals via the capacitive coupling network. Decoupling networks are required in order to avoid possible adverse effects on equipment not under test that may be powered by the same lines, and to provide sufficient decoupling impedance to the surge wave. The power cord between the EUT and the coupling/decoupling networks was shorter than 2 meters in length.

b) For test applied to unshielded un-symmetrically operated interconnection lines of EUT:

The surge was applied to the lines via the capacitive coupling. The coupling / decoupling networks didn't influence the specified functional conditions of the EUT. The interconnection line between the EUT and the coupling/decoupling networks was shorter than 2 meters in length.

c) For test applied to unshielded symmetrically operated interconnection / telecommunication lines of EUT:

The surge was applied to the lines via gas arrestors coupling. Test levels below the ignition point of the coupling arrestor were not specified. The interconnection line between the EUT and the coupling/decoupling networks was shorter than 2 meters in length.

#### 5.4.5. Test Result

Model Number	PM-3033					
Test Item	Surge					
Test Mode	Mode 1					
Angle	0, 90, 180, 270					
Date of Test	2015/09/11			Test Site	TE08	
Inject Line	Polarity	Voltage (kV)	Time Interval (Second)	Inject Method	Performance Criterion	Result
L-N	±	1	60	Direct	<input checked="" type="checkbox"/> A <input type="checkbox"/> B	Pass
L-PE	±	2	60	Direct	<input checked="" type="checkbox"/> A <input type="checkbox"/> B	Pass
N-PE	±	2	60	Direct	<input checked="" type="checkbox"/> A <input type="checkbox"/> B	Pass
L+N-PE	±	2	60	Direct	<input checked="" type="checkbox"/> A <input type="checkbox"/> B	Pass

Note: The testing performed is from lowest level up to the highest level as required by standard, but only highest level is shown on the report.

Criterion A: Operate as intended during and after the test

Criterion B: Operate as intended after the test

Criterion C: Loss/Error of function

Additional Information

EUT stopped operation and could / could not be reset by operator at \_\_\_\_\_ V/m at frequency \_\_\_\_\_ MHz.

No false alarms or other malfunctions were observed during or after the test.

#### 5.4.6. Test Photograph

Test Mode: Mode 1

Description: Front View of Surge Test – AC Mains Port



## 5.5. Conducted Susceptibility (CS)

### 5.5.1. Test Specification

EN 61000-4-6			
Environmental Phenomena	Units	Test Specification	Performance Criterion
Signal Ports and Telecommunication Ports			
Radio-Frequency Continuous Conducted	MHz	0.15-80	A
	V (rms, Un-modulated)	3	
	% AM (1kHz)	80	
Input DC Power Ports			
Radio-Frequency Continuous Conducted	MHz	0.15-80	A
	V (rms, Un-modulated)	3	
	% AM (1kHz)	80	
Input AC Power Ports			
Radio-Frequency Continuous Conducted	MHz	0.15-80	A
	V (rms, Un-modulated)	3	
	% AM (1kHz)	80	

EUT tested in accordance with the specifications given by the standard of EN 61000-4-6.

Step : 1%

### 5.5.2. Test Instrument

Equipment	Manufacturer	Model Number	Serial Number	Cal. Date	Cal. Period
Signal Line Coupling Decoupling Network	FCC	FCC-801--T2-RJ11	8017	07/21/2015	1 year
Signal Line Coupling Decoupling Network	FCC	FCC-801--T4-RJ45	8018	07/21/2015	1 year
Signal Line Coupling Decoupling Network	FCC	FCC-801-M2/M3-16A 8030	8030	07/21/2015	1 year
EM Injection Clamp	FCC	F-203I-23MM	8576	07/21/2015	1 year
NRP-Z91 POWER SENSOR	R&S	NRP-Z91	100613	07/19/2015	1 year
Amplifiers	ar	75A250A	328729	N.C.R.	-----
De-coupling Network	FCC	F-203I-23MM- DCN	8234	N.C.R.	-----
Test Site	ATL	TE08	TE08	N.C.R.	-----

Note: N.C.R. = No Calibration Request.

5.5.3. Setup

CDN Method

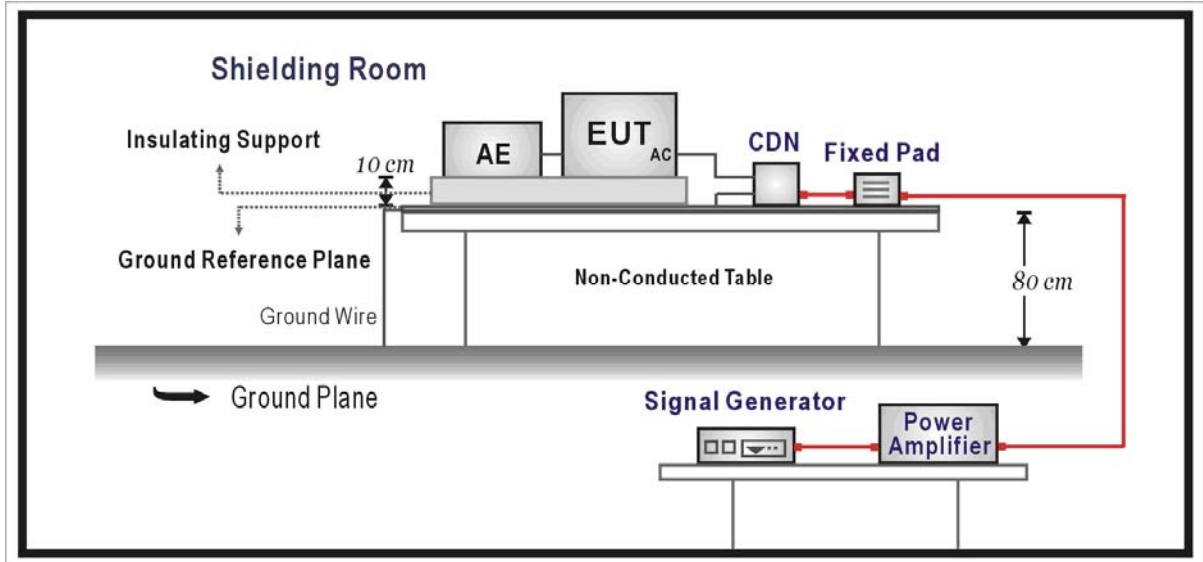

EM Clamp Method

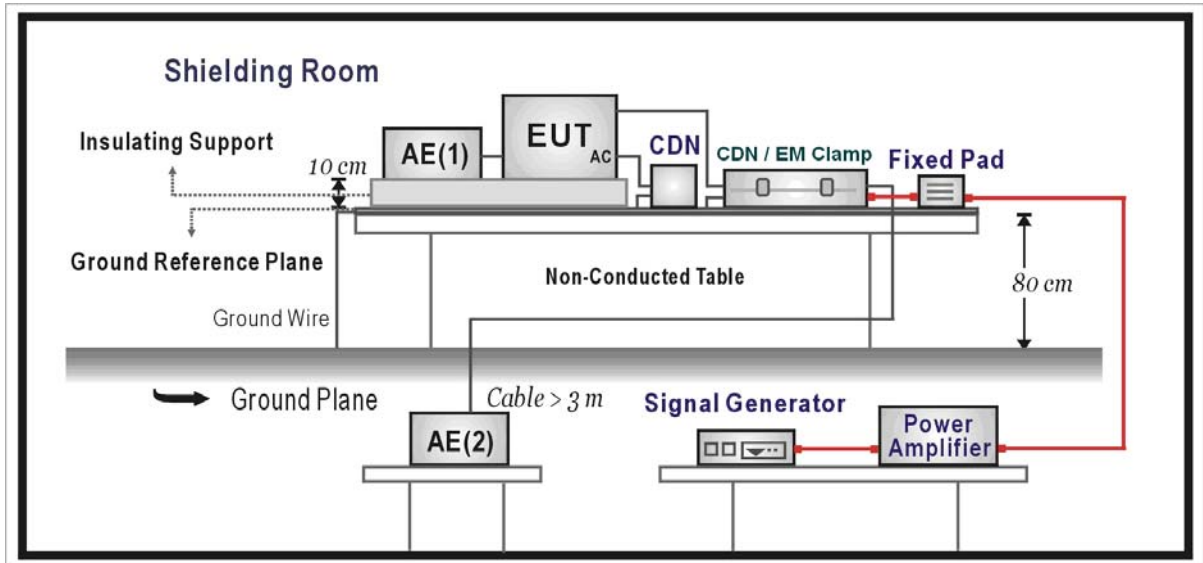

#### 5.5.4. Test Procedure

The EUT shall be tested within its intended operating and climatic conditions.

The test shall be performed with the test generator connected to each of the coupling and decoupling devices in turn, while the other non-excited RF input ports of the coupling devices are terminated by a 50-ohm load resistor.

The frequency range was swept from 150 kHz to 80 MHz, using the signal level established during the setting process and with a disturbance signal of 80 % amplitude. The signal was modulated with a 1 kHz sine wave, pausing to adjust the RF signal level or the switch coupling devices as necessary. The sweep rate was  $1.5 \times 10^{-3}$  decades/s. Where the frequency range is swept incrementally, the step size was 1 % of preceding frequency value from 150 kHz to 80 MHz.

The dwell time at each frequency was less than the time necessary for the EUT to be exercised, and able to respond. Sensitive frequencies such as clock frequency and harmonics or frequencies of dominant interest, was analyzed separately.

Attempts were made to fully exercise the EUT during testing, and to fully interrogate all exercise modes selected for susceptibility.

#### 5.5.5. Test Result

Model Number	PM-3033				
Test Item	Conducted Susceptibility				
Test Mode	Mode 1				
Date of Test	2015/09/10			Test Site	TE08
Frequency Band (MHz)	Field Strength (Vrms)	Inject Port	Inject Method	Performance Criterion	Result
0.15 ~ 80	3	AC Mains	CDN-M3	<input checked="" type="checkbox"/> A <input type="checkbox"/> B	PASS

Note: The testing performed is from lowest level up to the highest level as required by standard, but only highest level is shown on the report.

Criterion A: Operate as intended during and after the test

Criterion B: Operate as intended after the test

Criterion C: Loss/Error of function

Additional Information

EUT stopped operation and could / could not be reset by operator at \_\_\_\_\_ V/m at frequency \_\_\_\_\_ MHz.

No false alarms or other malfunctions were observed during or after the test.

**5.5.6. Test Photograph**

Test Mode: Mode 1

Description: Front View of CS Test – AC Mains Port

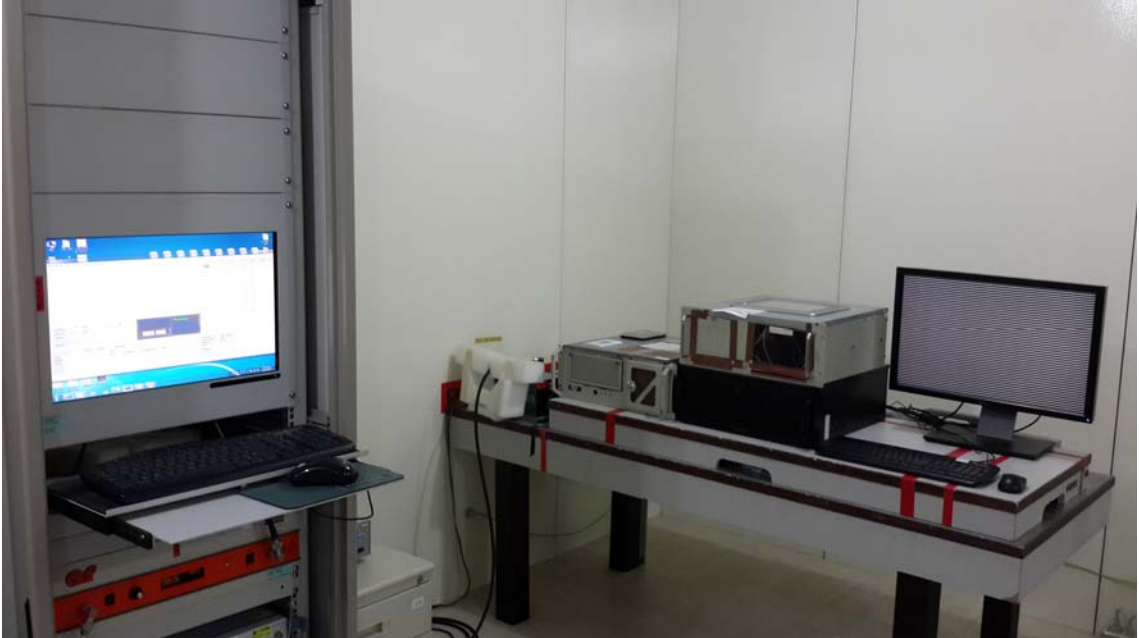

## 5.6. Power Frequency Magnetic Field (PMF)

### 5.6.1. Test Specification

EN 61000-4-8				
Item	Environmental Phenomena	Units	Test Specification	Performance Criterion
Enclosure Port				
	Power-Frequency Magnetic Field	Hz A/m (r.m.s.)	50 30	A

EUT tested in accordance with the specifications given by the standard of EN 61000-4-8.

Orientation : X, Y, Z

Test time : 180 Second

### 5.6.2. Test Instrument

Equipment	Manufacturer	Model Number	Serial Number	Cal. Date	Cal. Period
EMC Immunity Tester	EMC-PARTNER AG	TRANSIENT 2000IN6	952	02/16/2015	1 year
Magnetic Field Antenna	EMC-PARTNER AG	MF1000-1	155	02/05/2015	1 year
Test Site	ATL	TE08	TE08	N.C.R.	-----

Remark: <sup>(1)</sup> Calibration period 1 year. <sup>(2)</sup> Calibration period 2 years.

Note: N.C.R. = No Calibration Request.

### 5.6.3. Setup

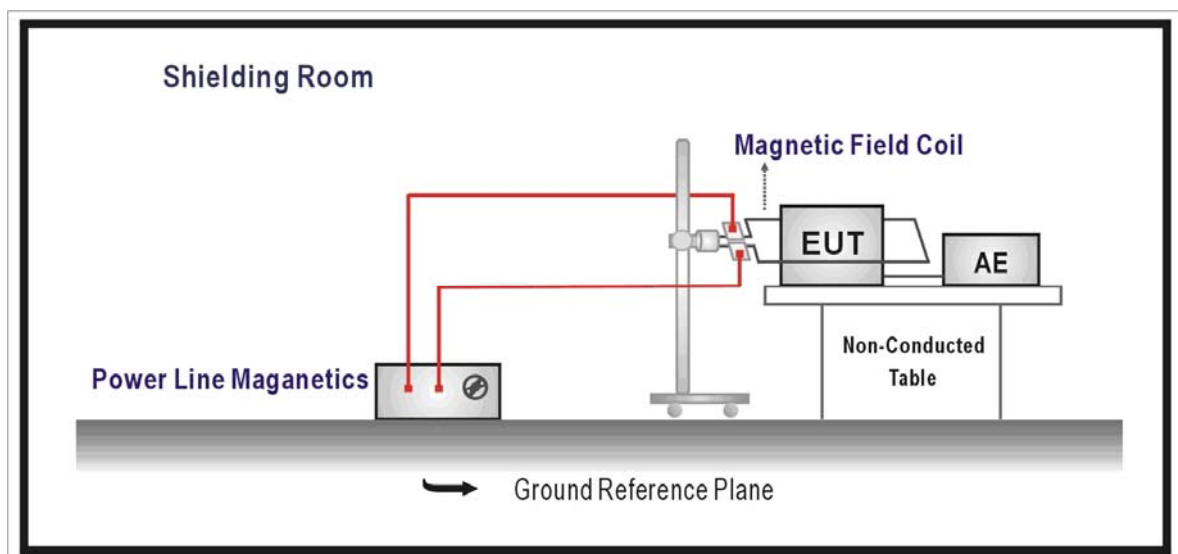

#### 5.6.4. Test Procedure

- a). The equipment was configured and connected to satisfy its functional requirements. It shall be placed on the GRP with the interposition of a 0.1m-thick insulating support.
- b). The equipment cabinets shall be connected to the safety earth directly on the GRP via the earth terminal of the EUT.
- c). The power supply, input and output circuits shall be connected to the sources of power supply, control and signal.
- d). The cables supplied or recommended by the equipment manufacturer shall be used. 1 meter of all cables used shall be exposed to the magnetic field.

#### 5.6.5. Test Result

Model Number	PM-3033			
Test Item	Power Frequency Magnetic Field			
Test Mode	Mode 1			
Date of Test	2015/09/11		Test Site	TE08
Polarization	Frequency (Hz)	Magnetic Strength (A/m)	Performance Criterion	Result
X Orientation	50	30	<input checked="" type="checkbox"/> A <input type="checkbox"/> B	PASS
Y Orientation	50	30	<input checked="" type="checkbox"/> A <input type="checkbox"/> B	PASS
Z Orientation	50	30	<input checked="" type="checkbox"/> A <input type="checkbox"/> B	PASS

Note: The testing performed is from lowest level up to the highest level as required by standard, but only highest level is shown on the report.

Criterion A: Operate as intended during and after the test

Criterion B: Operate as intended after the test

Criterion C: Loss/Error of function

Additional Information

EUT stopped operation and could / could not be reset by operator at \_\_\_\_\_ V/m at frequency \_\_\_\_\_ MHz.

No false alarms or other malfunctions were observed during or after the test.



**5.6.6. Test Photograph**

Test Mode: Mode 1

Description: Front View of PMF Test



## 5.7. Voltage Dips and Interruption

### 5.7.1. Test Specification

IEC 61000-4-11 / EN 61000-4-11			
Environmental Phenomena	Units	Test Specification	Performance Criterion
Input AC Power Ports			
Voltage Dips	0	% Residual	B
	1	Period	
	40	% Residual	C
	10/12	Period	
	70	% Residual	C
	25/30	Period	
Voltage Interruptions	0	% Residual	C
	250/300	Period	

### 5.7.2. Test Instrument

Equipment	Manufacturer	Model Number	Serial Number	Cal. Date	Cal. Period
EMC Immunity Tester	EMC-PARTNER AG	TRANSIENT 2000IN6	952	02/16/2015	1 year
Test Site	ATL	TE08	TE08	N.C.R.	-----

Note: N.C.R. = No Calibration Request.

### 5.7.3. Setup

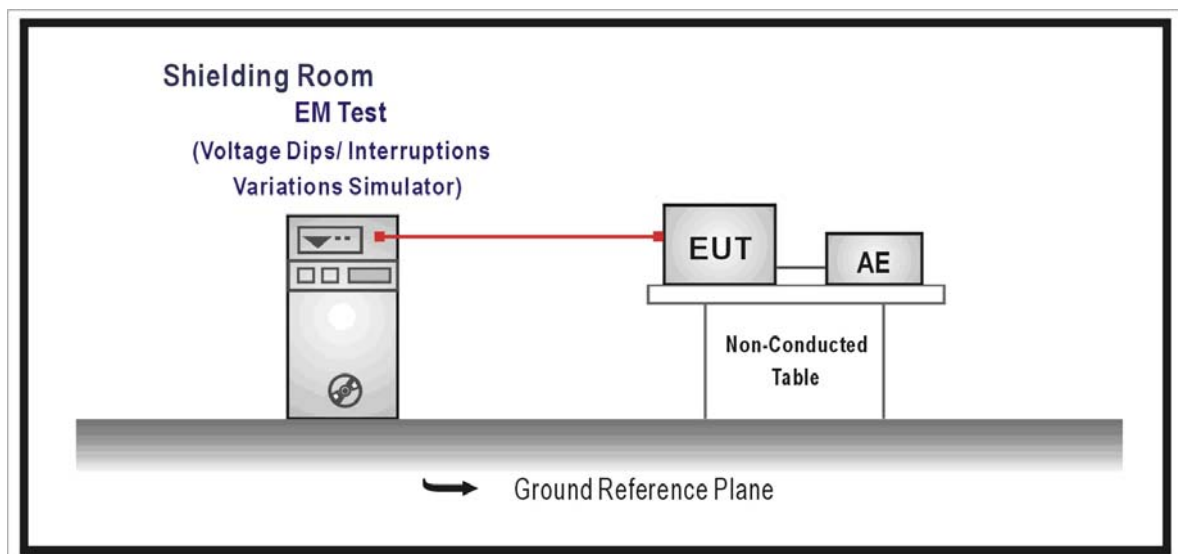

**5.7.4. Test Procedure**

1. The EUT and support units were located on a wooden table, 0.8 m away from ground floor.
2. Setting the parameter of tests and then perform the test software of test simulator.
3. Conditions changes to occur at 0 degree crossover point of the voltage waveform.
4. Recording the test result in test record form.

**5.7.5. Test Result**

Model Number	PM-3033				
Test Item	Voltage Dips and Interruption Measurement				
Test Mode	Mode 1				
Angle	0~360 degree		Step	45 degree	
Date of Test	2015/09/11		Test Site	TE08	
Test Voltage (Vac)	Voltage Residual (%)	Test Duration (periods)	Performance Criterion	Test Result	Observation
230	>95	1	<input checked="" type="checkbox"/> A <input type="checkbox"/> B <input type="checkbox"/> C	Pass	Note1
	30	25	<input checked="" type="checkbox"/> A <input type="checkbox"/> B <input type="checkbox"/> C	Pass	Note1
	60	10	<input type="checkbox"/> A <input type="checkbox"/> B <input checked="" type="checkbox"/> C	Pass	Note2
	>95	250	<input type="checkbox"/> A <input type="checkbox"/> B <input checked="" type="checkbox"/> C	Pass	Note2
100	>95	1	<input checked="" type="checkbox"/> A <input type="checkbox"/> B <input type="checkbox"/> C	Pass	Note1
	30	25	<input type="checkbox"/> A <input type="checkbox"/> B <input checked="" type="checkbox"/> C	Pass	Note2
	60	10	<input type="checkbox"/> A <input type="checkbox"/> B <input checked="" type="checkbox"/> C	Pass	Note2
	>95	250	<input type="checkbox"/> A <input type="checkbox"/> B <input checked="" type="checkbox"/> C	Pass	Note2

Note 1: The acceptance criteria were met, and the EUT passed the test.

Criterion A : Operate as intended during and after the test

Criterion B : Operate as intended after the test

Criterion C : Loss/Error of function

Additional Information

EUT stopped operation and could / could not be reset by operator at \_\_\_\_\_ dBuV(V) at frequency \_\_\_\_\_ MHz.

No false alarms or other malfunctions were observed during or after the test.

Note2: The power is temporary off and can be reset by the operator.

**5.7.6. Test Photograph**

Test Mode: Mode 1

Description: Front View of Dips Test



## 6 EUT Photograph

(1) EUT Photo

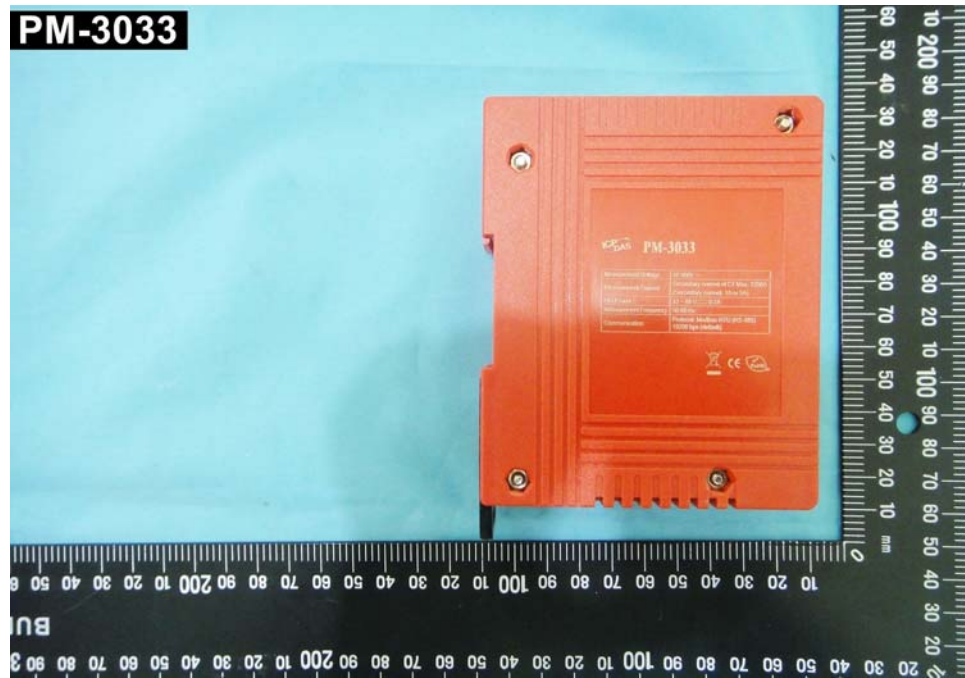

(2) EUT Photo





(3) EUT Photo



(4) EUT Photo

