

# User's Guide

**omega.com<sup>®</sup>**

Ω OMEGA<sup>®</sup>

**Shop online at**

***www.omega.com***

***e-mail: info@omega.com***

**ISO 9001**  
CERTIFIED  
CORPORATE QUALITY

STAMFORD, CT

**ISO 9002**  
CERTIFIED  
CORPORATE QUALITY

MANCHESTER, UK



**OME-A826PG**

**ISA-Bus Multi-Functional Board**

**Hardware Manual**



**OMEGAnet® Online Service**  
**www.omega.com**

**Internet e-mail**  
**info@omega.com**

### **Servicing North America:**

**USA:**  
ISO 9001 Certified

One Omega Drive, P.O. Box 4047  
Stamford CT 06907-0047  
TEL: (203) 359-1660 FAX: (203) 359-7700  
e-mail: info@omega.com

**Canada:**

976 Bergar  
Laval (Quebec) H7L 5A1, Canada  
TEL: (514) 856-6928 FAX: (514) 856-6886  
e-mail: info@omega.ca

### **For immediate technical or application assistance:**

**USA and Canada:** Sales Service: 1-800-826-6342 / 1-800-TC-OMEGA®  
Customer Service: 1-800-622-2378 / 1-800-622-BEST®  
Engineering Service: 1-800-872-9436 / 1-800-USA-WHEN®  
TELEX: 996404 EASYLINK: 62968934 CABLE: OMEGA

**Mexico:**

En Español: (001) 203-359-7803 e-mail: espanol@omega.com  
FAX: (001) 203-359-7807 info@omega.com.mx

### **Servicing Europe:**

**Benelux:**

Postbus 8034, 1180 LA Amstelveen, The Netherlands  
TEL: +31 (0)20 3472121 FAX: +31 (0)20 6434643  
Toll Free in Benelux: 0800 0993344  
e-mail: sales@omegaeng.nl

**Czech Republic:**

Frystatska 184, 733 01 Karviná, Czech Republic  
TEL: +420 (0)59 6311899 FAX: +420 (0)59 6311114  
Toll Free: 0800-1-66342 e-mail: info@omegashop.cz

**France:**

11, rue Jacques Cartier, 78280 Guyancourt, France  
TEL: +33 (0)1 61 37 29 00 FAX: +33 (0)1 30 57 54 27  
Toll Free in France: 0800 466 342  
e-mail: sales@omega.fr

**Germany/Austria:**

Daimlerstrasse 26, D-75392 Deckenpfronn, Germany  
TEL: +49 (0)7056 9398-0 FAX: +49 (0)7056 9398-29  
Toll Free in Germany: 0800 639 7678  
e-mail: info@omega.de

**United Kingdom:**

ISO 9002 Certified

One Omega Drive, River Bend Technology Centre  
Northbank, Irlam, Manchester  
M44 5BD United Kingdom  
TEL: +44 (0)161 777 6611 FAX: +44 (0)161 777 6622  
Toll Free in United Kingdom: 0800-488-488  
e-mail: sales@omega.co.uk

---

It is the policy of OMEGA to comply with all worldwide safety and EMC/EMI regulations that apply. OMEGA is constantly pursuing certification of its products to the European New Approach Directives. OMEGA will add the CE mark to every appropriate device upon certification.

The information contained in this document is believed to be correct, but OMEGA Engineering, Inc. accepts no liability for any errors it contains, and reserves the right to alter specifications without notice.

**WARNING:** These products are not designed for use in, and should not be used for, patient-connected applications.

# OME-A-826PG

*Hardware User's Manual*

---

# Tables of Contents

<b>1.</b>	<b>INTRODUCTION</b> .....	<b>4</b>
1.1	GENERAL DESCRIPTION .....	4
1.2	FEATURES.....	4
1.3	SPECIFICATIONS.....	5
1.3.1	<i>Power Consumption:</i> .....	5
1.3.2	<i>Analog Inputs</i> .....	5
1.3.3	<i>A/D Converter</i> .....	5
1.3.4	<i>D/A Converter</i> .....	6
1.3.5	<i>Digital I/O</i> .....	6
1.3.6	<i>Interrupt Channel</i> .....	6
1.3.7	<i>Programmable Timer/Counter</i> .....	7
1.3.8	<i>Direct Memory Access Channel (DMA)</i> .....	7
1.4	APPLICATIONS .....	8
1.5	PRODUCT CHECK LIST .....	8
<b>2.</b>	<b>HARDWARE CONFIGURATION</b> .....	<b>9</b>
2.1	BOARD LAYOUT .....	9
2.2	I/O BASE ADDRESS SETTING .....	10
2.3	JUMPER SETTING .....	11
2.3.1	<i>JP1 : D/A Internal Reference Voltage Selection</i> .....	11
2.3.2	<i>JP2/JP3 : D/A Int/Ext Ref Voltage Selection</i> .....	12
2.3.3	<i>JP4 : Single-ended/Differential Selection</i> .....	12
2.3.4	<i>JP5 : A/D Trigger Source Selection</i> .....	13
2.3.5	<i>JP7 : Interrupt Level Selection</i> .....	13
2.3.6	<i>JP6 : User Timer/Counter Clock Input Selection</i> .....	14
2.3.7	<i>JP8 : DMA DACK Selection, JP9 : DMA DRQ Selection</i> .....	15
2.3.8	<i>JP10 : Event Trigger Selection</i> .....	16
2.3.9	<i>I/O Register Address</i> .....	17
2.3.10	<i>8254 Counter</i> .....	18
2.3.11	<i>A/D Input Buffer Register</i> .....	19
2.3.12	<i>D/A Output Latch Register</i> .....	20
2.3.13	<i>D/I Input Buffer Register</i> .....	21
2.3.14	<i>Clear Interrupt Request</i> .....	21
2.3.15	<i>A/D Conversion Ready</i> .....	22
2.3.16	<i>A/D Gain Control Register</i> .....	23
2.3.17	<i>A/D Multiplex Control Register</i> .....	24
2.3.18	<i>A/D Mode Control Register</i> .....	24

---

2.3.19	<i>A/D Software Trigger Control Register</i> .....	26
2.3.20	<i>D/O Output Latch Register</i> .....	27
2.4	DIGITAL I/O .....	28
2.5	8254 TIMER/COUNTER.....	29
2.6	A/D CONVERSION.....	31
2.6.1	<i>A/D conversion flow</i> .....	32
2.6.2	<i>A/D Conversion Trigger Modes</i> .....	33
2.6.3	<i>A/D Transfer Modes</i> .....	33
2.6.4	<i>Software Trigger and Polling Technique</i> .....	34
2.7	D/A CONVERSION.....	35
2.8	ANALOG INPUT SIGNAL CONNECTION .....	36
2.9	USING DB-8225 CJC OUTPUT.....	40
<b>3.</b>	<b>PIN ASSIGNMENTS</b> .....	<b>41</b>
3.1	CN1/CN2/CN3 PIN ASSIGNMENT .....	41
3.1.1	<i>FOR SINGLE-ENDED SIGNAL</i> .....	42
3.1.2	<i>FOR DIFFERENTIAL SIGNAL</i> .....	43
3.2	DAUGHTER BOARD.....	44
3.2.1	<i>OME-DB-8225</i> .....	44
3.2.2	<i>OME-DB-37</i> .....	44
3.2.3	<i>OME-DB-16P</i> .....	44
3.2.4	<i>OME-DB-16R</i> .....	44
<b>4.</b>	<b>CALIBRATION</b> .....	<b>45</b>
4.1	CALIBRATION VR DESCRIPTION .....	45
4.2	D/A CALIBRATION STEPS .....	46
4.3	A/D CALIBRATION STEPS .....	47
<b>5.</b>	<b>DIAGNOSTIC UTILITY</b> .....	<b>48</b>
5.1	INTRODUCTION .....	48
5.2	RUNNING THE DIAGNOSTIC UTILITY .....	50
5.2.1	<i>Setup</i> .....	51
5.2.2	<i>CALIBRATION</i> .....	53
5.2.3	<i>FUNCTION TEST</i> .....	54
5.2.4	<i>SPECIAL TEST</i> .....	62
5.2.5	<i>Help</i> .....	63

---

# 1. Introduction

## 1.1 General Description

The OME-A-826PG is a 16 bit high performance, multi-function analog, digital I/O board for the PC AT compatible computer. A software programmable gain amplifier has gain of 1, 2, 4, 8. The OME-A-826PG offer 16 single-ended or 8 differential analog inputs. The maximum sample rate of A/D converter is about 100Ksample/sec. There are two 12-bits DAC with voltage outputs, 16 channels of TTL-compatible digital input, 16 channels of TTL-compatible digital output and one 16-bit counter/timer channel for timing input and output.

Using ASC-TI486/33M CPU board of ICP as testing platform, the conversion speed of OME-A-826PG is given below :

- **Polling mode** : about 100Ksample/sec
- **Interrupt mode** : about 60Ksample/sec
- **DMA mode** : about 100Ksample/sec

## 1.2 Features

- 16 Bit high resolution & high speed
- The maximum sample rate of A/D converter is about 100 K sample/sec
- 16 single-ended or 8 differential analog input signals
- Software selectable input ranges
- A/D trigger mode: software trigger, pacer trigger, external trigger, event trigger
- Programmable gain of 1, 2, 4 or 8
- 2 channel of 12-bit D/A voltage output
- 16 digital input /16 digital output (TTL compatible)
- Interrupt handling
- Bipolar operation
- 1 channel general purpose programmable 16 bits timer/counter
- PC AT compatible ISA bus

---

## 1.3 Specifications

### 1.3.1 Power Consumption:

- +5V @ 960 mA maximum, OME-A-826PG
- Operating temperature: 0°C to 50°C (32 to 122°F)

### 1.3.2 Analog Inputs

- Channels: 16 single-ended or 8 differential
- Input range: (software programmable)  
OME-A-826PGL: Bipolar  $\pm 10V$ ,  $\pm 5V$ ,  $\pm 2.5V$ ,  $\pm 1.25V$ ,
- Input current: 250 nA max (125 nA typical ) at 25°C
- On chip sample and hold
- Over voltage: continuous single channel to **70Vp-p**
- Input impedance:  $10^4 \Omega // 6pF$

### 1.3.3 A/D Converter

- Type: successive approximation , Burr Brown ADS 7805 or equivalent
- Conversion time: 8 micro sec.
- Accuracy : +/- 3 count
- Resolution : 16 bits

---

## 1.3.4 D/A Converter

- Channels: 2 independent
- Type: 12 bit multiplying, Analog device AD-7541 or equivalent
- Linearity:  $\pm 1/2$  bit
- Output range: 0 to 5V or 0 to 10V jumper selected , may be used with other AC or DC reference input Maximum output limit  $\pm 10V$
- Output drive:  $\pm 5mA$
- settling time: 0.6 microseconds to 0.01% for full scale step

## 1.3.5 Digital I/O

- Output port: 16 bits, TTL compatible
- Input port: 16 bits, TTL compatible

## 1.3.6 Interrupt Channel

- Level: 3, 4, 5, 6, 7, 10, 11, 12, 14, 15, jumper selectable
- Enable: Via control register



---

## 1.3.7 Programmable Timer/Counter

- Type: 82C54 -8 programmable timer/counter
- Counters: The counter1 and counter2 are cascaded as a 32 bits pacer timer  
The counter0 is used as user timer/counter. The software driver use counter0 to implement a machine independent timer.
- Clock input frequency: DC to 10 MHz
- Pacer output: 0.00047Hz to 0.5MHz
- Input, gate: TTL compatible
- Internal Clock: 2 MHz

## 1.3.8 Direct Memory Access Channel (DMA)

- Level: CH1 or CH3, jumper selectable
- Enable: via DMA bit of control register
- Termination: by interrupt on T/C
- Transfer rate: 100K conversions/sec. (DOS Software manual, sec. 4.11)

---

## 1.4 Applications

- Signal analysis
- FFT & frequency analysis
- Transient analysis
- Production test
- Process control
- Vibration analysis
- Energy management
- Industrial and lab. measurement and control

## 1.5 Product Check List

In addition to this manual, the package includes the following items:

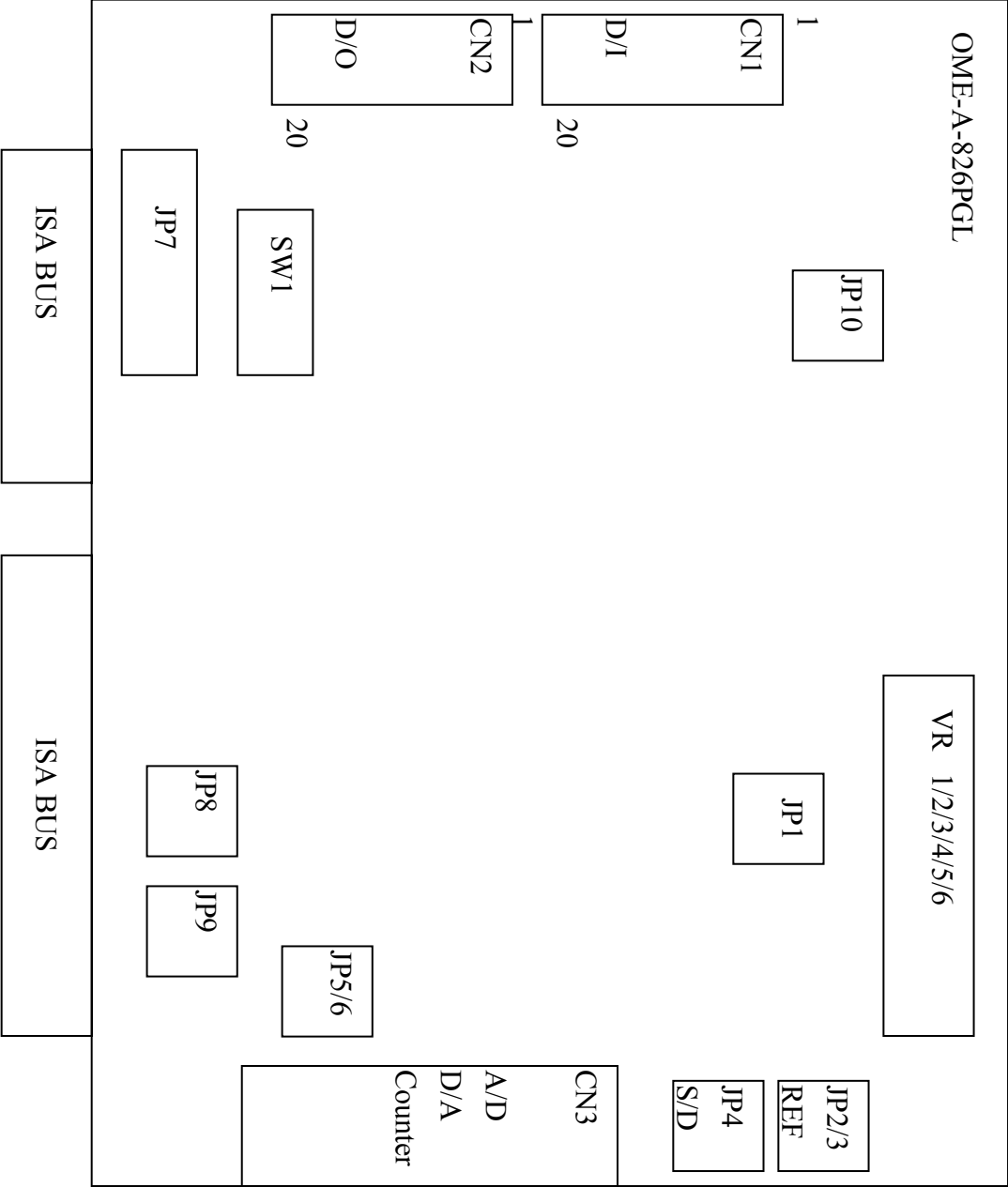
- OME-A-826PG multifunction card
- OME-A-826PG utility diskette

### **Attention!**

If any of these items is missing or damaged, contact the dealer who provides you this product. Save the shipping materials and carton in case you want to ship or store the product in the future.

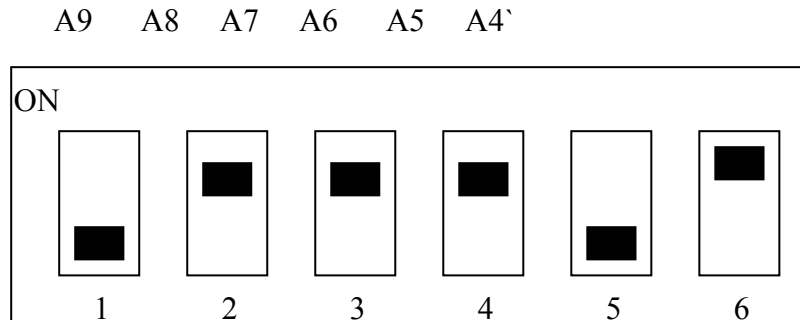
# 2. Hardware Configuration

## 2.1 Board Layout



## 2.2 I/O Base Address Setting

The OME-A-826PG occupies 16 consecutive locations in I/O address space. The base address is set by DIP switch SW1. The default address is 0x220.



SW1 : BASE ADDRESS

BASE ADDR	A9	A8	A7	A6	A5	A4
200-20F	OFF	ON	ON	ON	ON	ON
210-21F	OFF	ON	ON	ON	ON	OFF
<b>220-22F(☑)</b>	<b>OFF</b>	<b>ON</b>	<b>ON</b>	<b>ON</b>	<b>OFF</b>	<b>ON</b>
230-23F	OFF	ON	ON	ON	OFF	OFF
240-24F	OFF	ON	ON	OFF	ON	ON
250-25F	OFF	ON	ON	OFF	ON	OFF
260-26F	OFF	ON	ON	OFF	OFF	ON
270-27F	OFF	ON	ON	OFF	OFF	OFF
280-28F	OFF	ON	OFF	ON	ON	ON
:	:	:	:	:	:	:
2F0-2EF	OFF	ON	OFF	OFF	OFF	OFF
300-30F	OFF	OFF	ON	ON	ON	ON
310-31F	OFF	OFF	ON	ON	ON	OFF
:	:	:	:	:	:	:
3F0-3FF	OFF	OFF	OFF	OFF	OFF	OFF

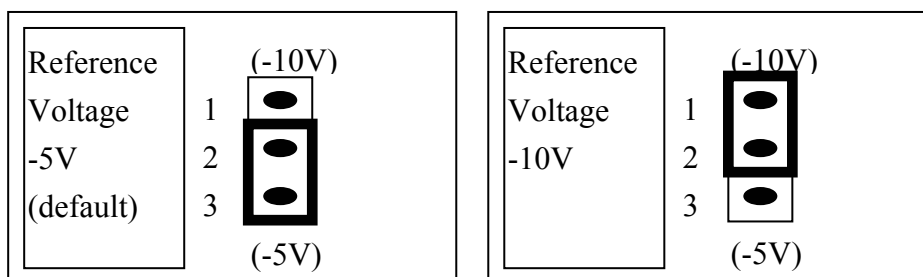
(☑) : default base address is 0x220

The PC I/O port mapping is given below.

ADDRESS	Device	ADDRESS	DEVICE
000-1FF	PC reserved	320-32F	XT Hard Disk
200-20F	Game/control	378-37F	Parallel Printer
210-21F	XT Expansion Unit	380-38F	SDLC
238-23F	Bus Mouse/Alt. Bus Mouse	3A0-3AF	SDLC
278-27F	Parallel Printer	3B0-3BF	MDA/Parallel Printer
2B0-2DF	EGA	3C0-3CF	EGA
2E0-2E7	AT GPIB	3D0-3DF	CGA
2E8-2EF	Serial Port	3E8-3EF	Serial Port
2F8-2FF	Serial Port	3F0-3F7	Floppy Disk
300-31F	Prototype Card	3F8-3FF	Serial Port

## 2.3 Jumper Setting

### 2.3.1 JP1 : D/A Internal Reference Voltage Selection

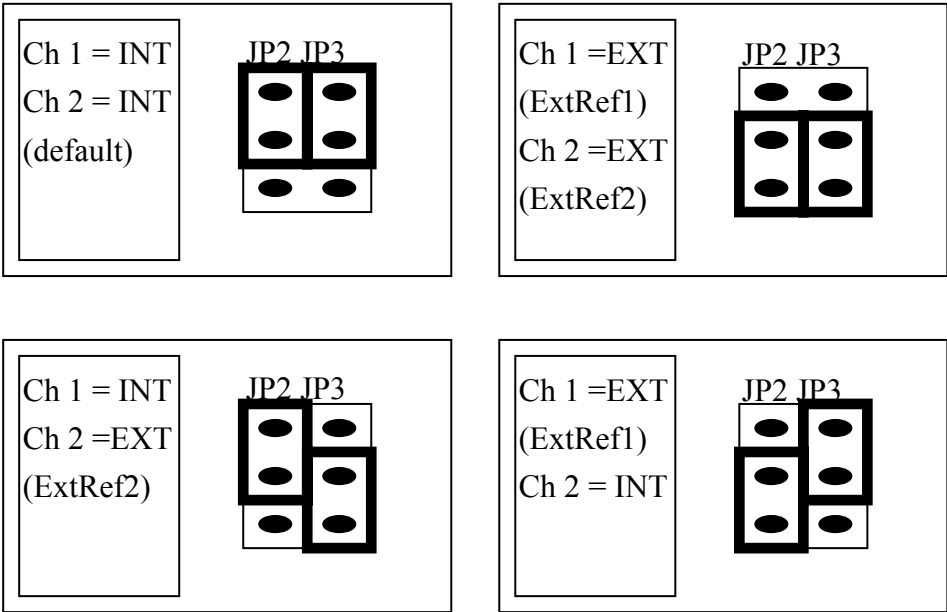


Select (-5V): D/A voltage output range = 0 to 5V (both channel)

Select (-10V): D/A voltage output range = 0 to 10V (both channel)

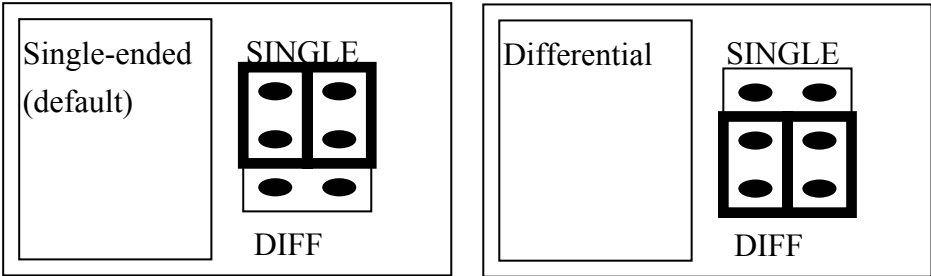
**JP1 is validate only if JP2 /JP3 select D/A internal reference voltage**

### 2.3.2 JP2/JP3 : D/A Int/Ext Ref Voltage Selection



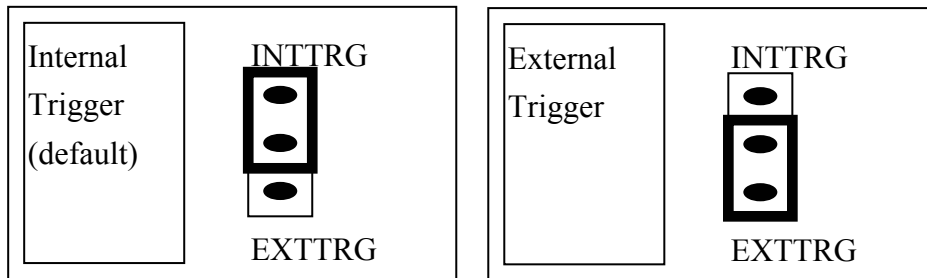
If JP2/JP3 select **internal reference**, then JP1 select **-5V/-10V** internal reference voltage. If JP2/JP3 select **external reference**, then **ExtRef1, CN3 pin 31**, is the external reference voltage for DA channel 1. and **ExtRef2, CN3 pin 12**, is the external reference voltage for DA Channel 2. If user provides AC ± 10V external reference voltage, the D/A output voltage may be AC ± 10V

### 2.3.3 JP4 : Single-ended/Differential Selection



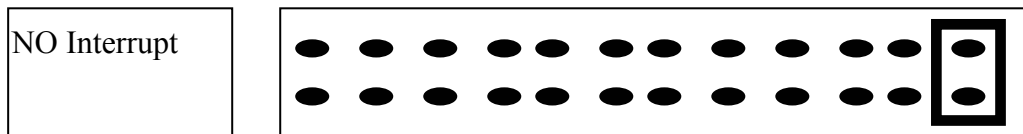
The OME-A-826PG offer 16 single-ended or 8 differential analog input signals. The JP4 select single-ended/differential. The user can not select single-ended and differential simultaneously.

## 2.3.4 JP5 : A/D Trigger Source Selection

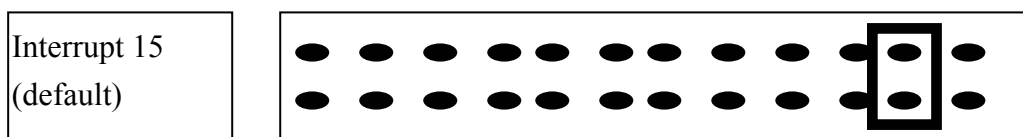


The OME-A-826PG supports two trigger type, **internal trigger** and **external trigger**. The external trigger signal comes from **ExtTrg, CN3 pin 17**. There are two types of internal trigger, **software trigger** and **pacemaker trigger**.

## 2.3.5 JP7 : Interrupt Level Selection



IRQ 3 4 5 6 7 9 10 11 12 14 15 NC

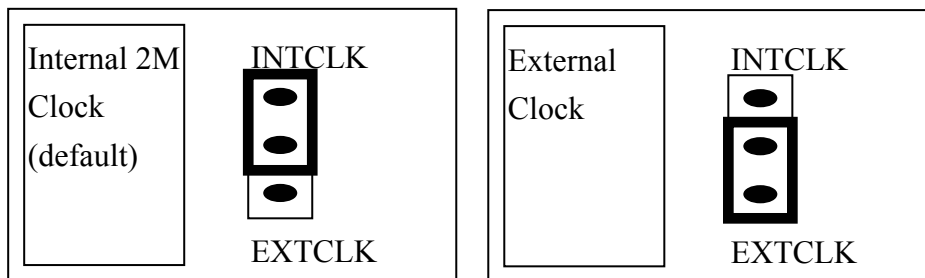


IRQ 3 4 5 6 7 9 10 11 12 14 15 NC

The interrupt channel **can not be shared**. The A826 software driver can support 8 different boards in one system but only **2 of these cards** can use interrupt transfer function.

---

## 2.3.6 JP6 : User Timer/Counter Clock Input Selection



The OME-A-826PG has 3 independent 16 bits timer/counter. The cascaded counter1 and counter2 are used as **pacemaker timer**. The counter0 can be used as a user programmable timer/counter. The user programmable timer/counter can select **2M internal clock** or **external clock ExtCLK, CN3 pin 37**. The block diagram is given in section 2.6. The clock source must be very **stable**. It is recommended to use internal 2M clock.

The OME-A-826PG software driver use the counter0 as a machine independent timer. user can use **A826\_Delay()** subroutineto program the counter 0 as a machine independent timer. The detail information is given in section 2.6.

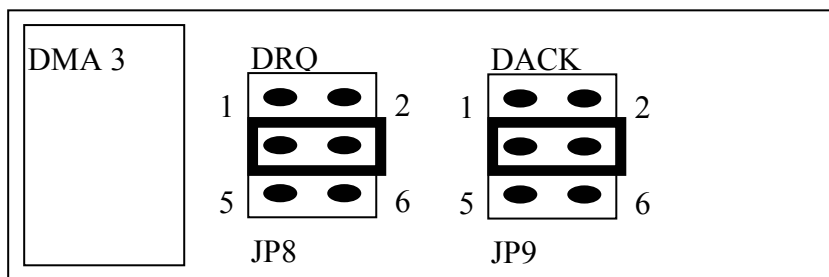
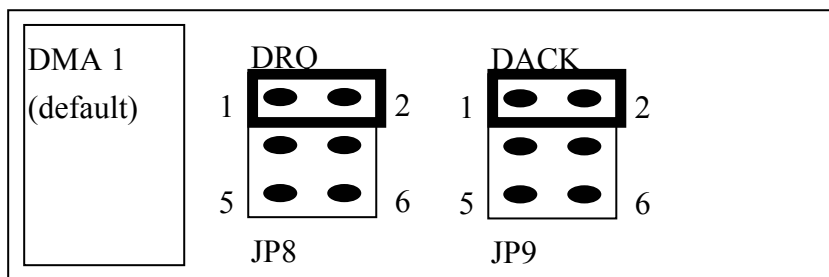
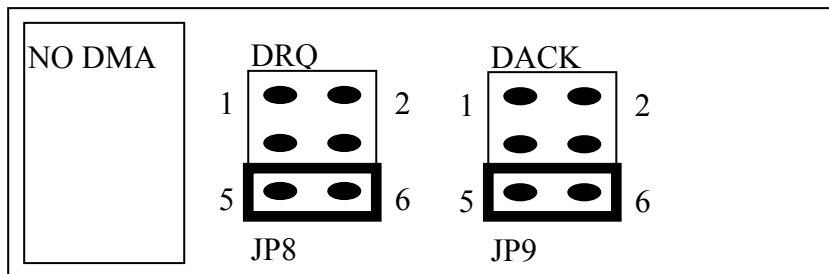
**NOTE : if using A826\_Delay(), the JP6 must select internal 2M clock.**



---

### 2.3.7 JP8 : DMA DACK Selection,

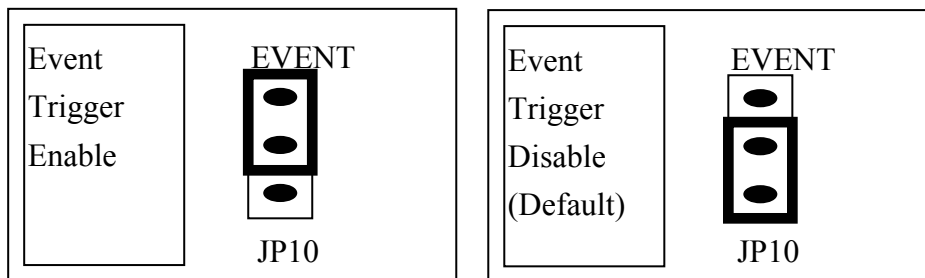
### JP9 : DMA DRQ Selection



**The DMA channel can not shared.** The OME-A-826PG software driver can support 8 different boards in one PC based system, but only **two of these boards** can use DMA transfer function.

---

## 2.3.8 JP10 : Event Trigger Selection



Both of the machine independent timer and the event trigger controller use timer/counter 0. Only one of these two functions can be implemented. So the user can not use both functions at the same time.

---

## 2.3.9 I/O Register Address

The OME-A-826PG occupies 16 consecutive PC I/O addresses.

The following table lists the registers and their locations.

<b>Address</b>	<b>Read</b>	<b>Write</b>
Base+0	8254 Counter 0	8254 Counter 0
Base+1	8254 Counter 1	8254 Counter 1
Base+2	8254 Counter 2	8254 Counter 2
Base+3	Reserved	8254 Counter Control
Base+4	A/D Low Byte	D/A Channel 0 Low Byte
Base+5	A/D High Byte	D/A Channel 0 High Byte
Base+6	DI Low Byte	D/A Channel 1 Low Byte
Base+7	DI High Byte	D/A Channel 1 High Byte
Base+8	A/D Conversion Ready	A/D Clear Interrupt Request
Base+9	Reserved	A/D Gain Control
Base+A	Reserved	A/D Multiplexer Control
Base+B	Reserved	A/D Mode Control
Base+C	Reserved	A/D Software Trigger Control
Base+D	Reserved	DO Low Byte
Base+E	Reserved	DO High Byte

---

## 2.3.10 8254 Counter

The 8254 Programmable timer/counter has 4 registers from Base+0 through Base+3. For detailed programming information about 8254, please refer to Intel's "Microsystem Components Handbook".

Address	Read	Write
Base+0	8254 Counter 0	8254 Counter 0
Base+1	8254 Counter 1	8254 Counter 1
Base+2	8254 Counter 2	8254 Counter 2
Base+3	Reserved	8254 Counter Control

### 8254 Counter Control Word

SC1	SC0	RW1	RW0	M2	M1	M0	BCD
Select Counter		Read/Write		Mode Select			BCD

## 2.3.11 A/D Input Buffer Register

(READ) Base+4 : A/D Low Byte Data Format

Bit 7	Bit 6	Bit 5	Bit 4	Bit 3	Bit 2	Bit 1	Bit 0
D7	D6	D5	D4	D3	D2	D1	D0

(READ) Base+5 : A/D High Byte Data Format

Bit 7	Bit 6	Bit 5	Bit 4	Bit 3	Bit 2	Bit 1	Bit 0
D15	D14	D13	D12	D11	D10	D9	D8

A/D 16 bits data : D15.....D0, D15=MSB, D0=LSB

The low 8 bits A/D data are stored in address BASE+4 and the high 8 bits data are stored in address BASE+5.

### Ideal Input Voltages and Output Codes Table

Description	Analog input	BINARY CODE	HEX CODE
Full Scale Range	-10 ~ +10 V		
Least Significant Bit (LSB)	305 uV		
+Full Scale (10V-1LSB)	9.999695V	0111 1111 1111 1111	7FFF
Midscale	0V	0000 0000 0000 0000	0000
One LSB below Midscale	-305uV	1111 1111 1111 1111	FFFF
- Full Scale	-10V	1000 0000 0000 0000	8000

---

## 2.3.12 D/A Output Latch Register

(WRITE) Base+4 : Channel 1 D/A Low Byte Data Format

Bit 7	Bit 6	Bit 5	Bit 4	Bit 3	Bit 2	Bit 1	Bit 0
D7	D6	D5	D4	D3	D2	D1	D0

(WRITE) Base+5 :Channel 1 D/A High Byte Data Format

Bit 7	Bit 6	Bit 5	Bit 4	Bit 3	Bit 2	Bit 1	Bit 0
X	X	X	X	D11	D10	D9	D8

(WRITE) Base+6 : Channel 2 D/A Low Byte Data Format

Bit 7	Bit 6	Bit 5	Bit 4	Bit 3	Bit 2	Bit 1	Bit 0
D7	D6	D5	D4	D3	D2	D1	D0

(WRITE) Base+7 :Channel 2 D/A High Byte Data Format

Bit 7	Bit 6	Bit 5	Bit 4	Bit 3	Bit 2	Bit 1	Bit 0
X	X	X	X	D11	D10	D9	D8

D/A 12 bits output data: D11..D0, D11=MSB, D0=LSB, X= don't care

The D/A converter will convert the 12 bits digital data to analog output. The low 8 bits of **D/A channel 1** are stored in address BASE+4 and high 4 bits are stored in address BASE+5. The address BASE+6 and BASE+7 store the 12 bits data for **D/A channel 2**. The D/A output latch registers are designed as a “**double buffered**” structure, so the analog output latch registers will be updated until the high 4 bits digital data are written. **the user must send low 8 bits first and then send high 4 bits to update the 12 bits AD output** latch register.

**NOTE : Send low 8 bits first, then send high 4 bits.**

---

## 2.3.13 D/I Input Buffer Register

(READ) Base+6 : D/I Input Buffer Low Byte Data Format

Bit 7	Bit 6	Bit 5	Bit 4	Bit 3	Bit 2	Bit 1	Bit 0
D7	D6	D5	D4	D3	D2	D1	D0

(READ) Base+7 : D/I Input Buffer High Byte Data Format

Bit 7	Bit 6	Bit 5	Bit 4	Bit 3	Bit 2	Bit 1	Bit 0
D15	D14	D13	D12	D11	D10	D9	D8

D/I 16 bits input data : D15..D0, D15=MSB, D0=LSB

The OME-A-826PG provides 16 TTL compatible digital input. The low 8 bits are stored in address BASE+6. The high 8 bits are stored in address BASE+7.

## 2.3.14 Clear Interrupt Request

(WRITE) Base+8 : Clear Interrupt Request Format

Bit 7	Bit 6	Bit 5	Bit 4	Bit 3	Bit 2	Bit 1	Bit 0
X	X	X	X	X	X	X	X

X=don't care, XXXXXXXX=any 8 bits data is validate

If OME-A-826PG is working in the interrupt transfer mode, a on-board hardware status bit will be set after each A/D conversion. This bit must be **clear by software** before next hardware interrupt. Writing any value to address BASE+8 will clear this hardware bit and the hardware will generate another interrupt when next A/D conversion is completed.

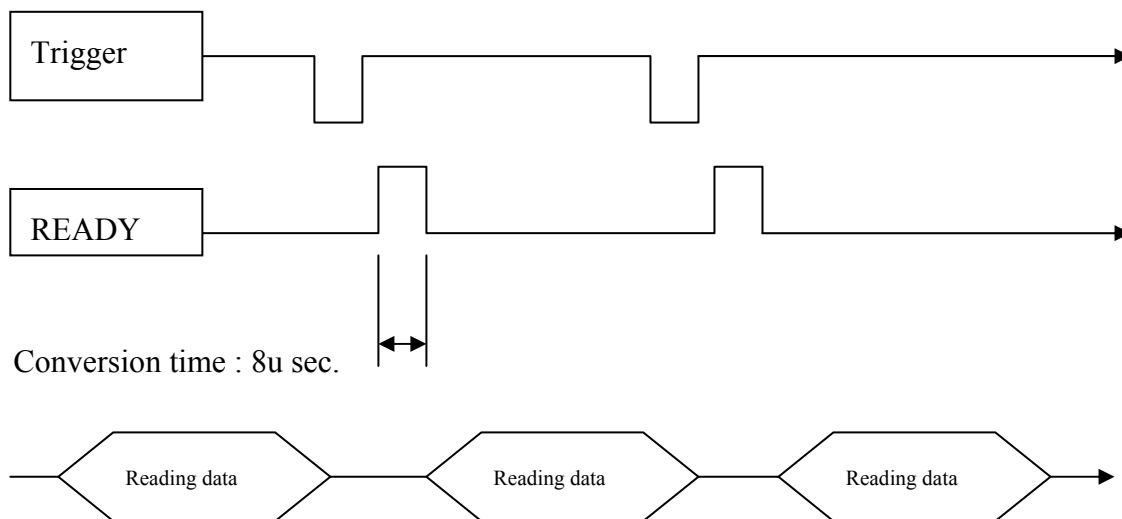
## 2.3.15 A/D Conversion Ready

(READ) Base+8 A/D Data Conversion Ready Format

Bit 7	Bit 6	Bit 5	Bit 4	Bit 3	Bit 2	Bit 1	Bit 0
X	X	X	READY	X	X	X	X

READY = 0 : A/D Conversion Ready

READY = 1 : A/D Conversion Not Ready



The READY bit is used as an indicator for A/D conversion. **When a A/D conversion is completed, the READY bit will be clear to zero.**



---

## 2.3.16 A/D Gain Control Register

(WRITE) Base+9 : A/D Gain Control Register Format

Bit 7	Bit 6	Bit 5	Bit 4	Bit 3	Bit 2	Bit 1	Bit 0
X	X	X	X	X	X	GAIN1	GAIN0

The **OME-A-826PG** provides gain factor of **1/2/4/8**

**NOTE:** If gain control code changed, the hardware need to delay extra gain settling time. The gain settling time is different for different gain control code. The software driver does not take care the gain settling time, so the user need to delay the gain settling time if gain changed. If the application program need to run in different machines, the user needs to implement a machine independent timer. The software driver, **A826\_delay()**, is designed for this purpose. If user uses this subroutine then the counter2 introduced in sec 2.6 is reserved by software driver to implement this machine independent timer.

## OME-A-826PGL GAIN CONTROL CODE TABLE

Settling Time	GAIN	Input Range	GAIN1	GAIN0
23 us	1	+/- 10V	0	0
23 us	2	+/- 5V	0	1
25 us	4	+/- 2.5V	1	0
28 us	8	+/- 1.25V	1	1

## 2.3.17 A/D Multiplex Control Register

(WRITE) Base+A: A/D Multiplexer Control Register Format

Bit 7	Bit 6	Bit 5	Bit 4	Bit 3	Bit 2	Bit 1	Bit 0
X	X	X	X	D3	D2	D1	D0

A/D input channel selection data = 4 bits : D3..D0, D3=MSB, D0=LSB, X=don't care

**Single-ended mode: D3..D0**

**Differential mode: D2..D0, D3=don't care**

The OME-A-826PG provides 16 single-ended or 8 differential analog input signals. In single-ended mode D3..D0 select the active channel. In differential mode D2..D0 select the active channel and D3 will be don't care.

**NOTE: The settling time of multiplexer depend on source resistance.of input sources.**

**source resistance = about 0.1K ohm → settling time = about 3 us.**

**source resistance = about 1K ohm → settling time = about 5 us.**

**source resistance = about 10K ohm → settling time = about 10 us.**

**source resistance = about 100K ohm → settling time = about 100 us.**

## 2.3.18 A/D Mode Control Register

(WRITE) Base+B: A/D Mode Control Register Format

Bit 7	Bit 6	Bit 5	Bit 4	Bit 3	Bit 2	Bit 1	Bit 0
X	X	X	X	X	D2	D1	D0

X=don't care

JP5 Select Internal Trigger							
Mode Select			Trigger Type		Transfer Type		
D2	D1	D0	Software Trig	Pacer Trig	Software	Interrupt	DMA
0	0	0	X	X	X	X	X
0	0	1	Select	X	Select	X	X
0	1	0	X	Select	X	X	Select
1	1	0	X	Select	Select	Select	X

X=disable

JP5 Select External Trigger						
Mode Select			Trigger Type	Transfer Type		
D2	D1	D0	External Trigger	Software	Interrupt	DMA
0	0	0	X	X	X	X
0	0	1	X	X	X	X
0	1	0	Select	X	X	Select
1	1	0	Select	Select	Select	X

The A/D conversion operation can be divided into 2 stages, **trigger stage and transfer stage**. The trigger stage will generate a trigger signal to A/D converter and the transfer stage will transfer the result to the CPU.

The trigger method may be **internal trigger** or **external trigger**. The internal trigger can be **software trigger** or **pacemaker /event trigger**. **The software trigger is very simple but can not control the sampling rate very precisely.** In software trigger mode, the program issues a software trigger command any time needed. Then the program will poll the A/D status bit until the ready bit is 0.

**The pacemaker/event trigger can control the sampling rate very precisely. So the converted data can be used to reconstruct the wave form of analog input signal.** In pacemaker trigger mode, the pacemaker timer will generate trigger signals to A/D converter periodic. These converted data can be transfer to the CPU by polling or interrupt or DMA transfer method.

The software driver provides three data transfer methods, **polling, interrupt and DMA**. The polling subroutine, A826\_AD\_PollingVar() or A826\_AD\_PollingArray(), set A/D mode control register to **0x01**. This control word means software trigger and polling transfer. The interrupt subroutine, A826\_AD\_INT\_START(...), set A/D mode control mode register to **0x06**. This control word means pacemaker trigger and interrupt transfer. The DMA subroutine, A826\_AD\_DMA\_START(...), set A/D mode control register to **0x02**. This control word means pacemaker trigger and DMA transfer.

---

## 2.3.19 A/D Software Trigger Control Register

(WRITE) Base+C: A/D Software Trigger Control Register Format

Bit 7	Bit 6	Bit 5	Bit 4	Bit 3	Bit 2	Bit 1	Bit 0
X	X	X	X	X	X	X	X

X=don't care, XXXXXXXX=any 8 bits data is validate

The A/D converter can be triggered by software trigger or pacer trigger. Writing any value to address BASE+C will generate a trigger pulse to A/D converter and initiated a A/D conversion operation. The address BASE+8 offers a ready bit to indicate a A/D conversion complete.

The software driver use this control word to detect the OME-A-826PG hardware board. **The software initiates a software trigger and checks the ready bit** . If the ready bit can not clear to zero in a fixed time, the software driver will return a error message. If the I/O BASE address setting error, the ready bit will not be clear to zero. The software driver, **A826\_CheckAddress()**, use this method to detect the of I/O BASE address setting

---

## 2.3.20 D/O Output Latch Register

(WRITE) Base+D: D/O Output Latch Low Byte Data Format

Bit 7	Bit 6	Bit 5	Bit 4	Bit 3	Bit 2	Bit 1	Bit 0
D7	D6	D5	D4	D3	D2	D1	D0

(WRITE) Base+E: D/O Output Latch High Byte Data Format

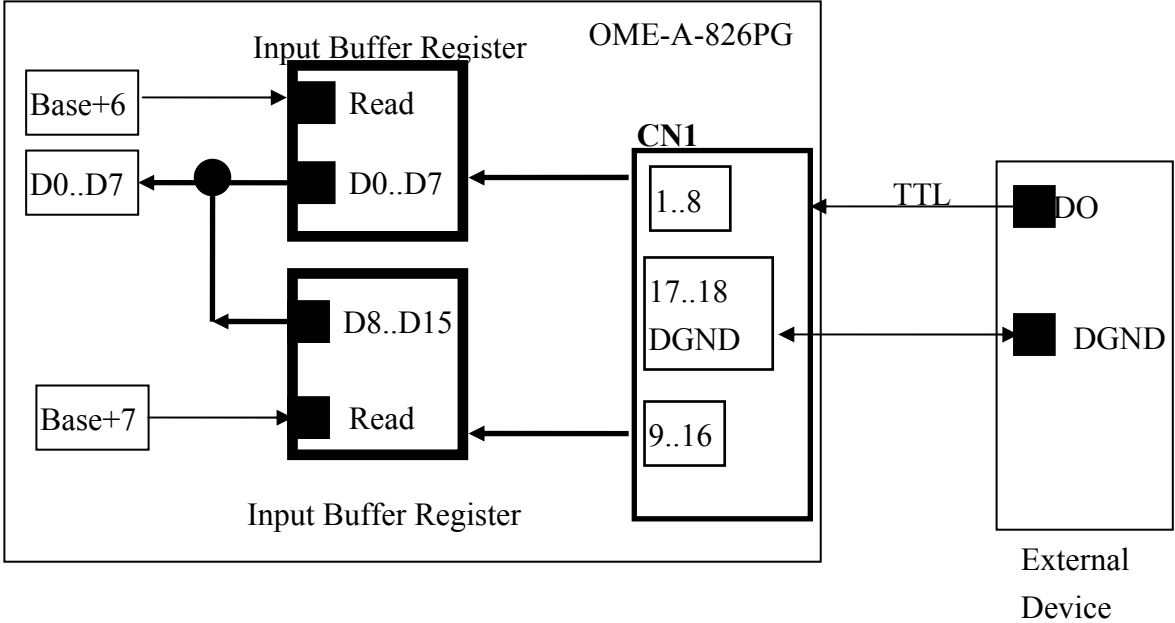
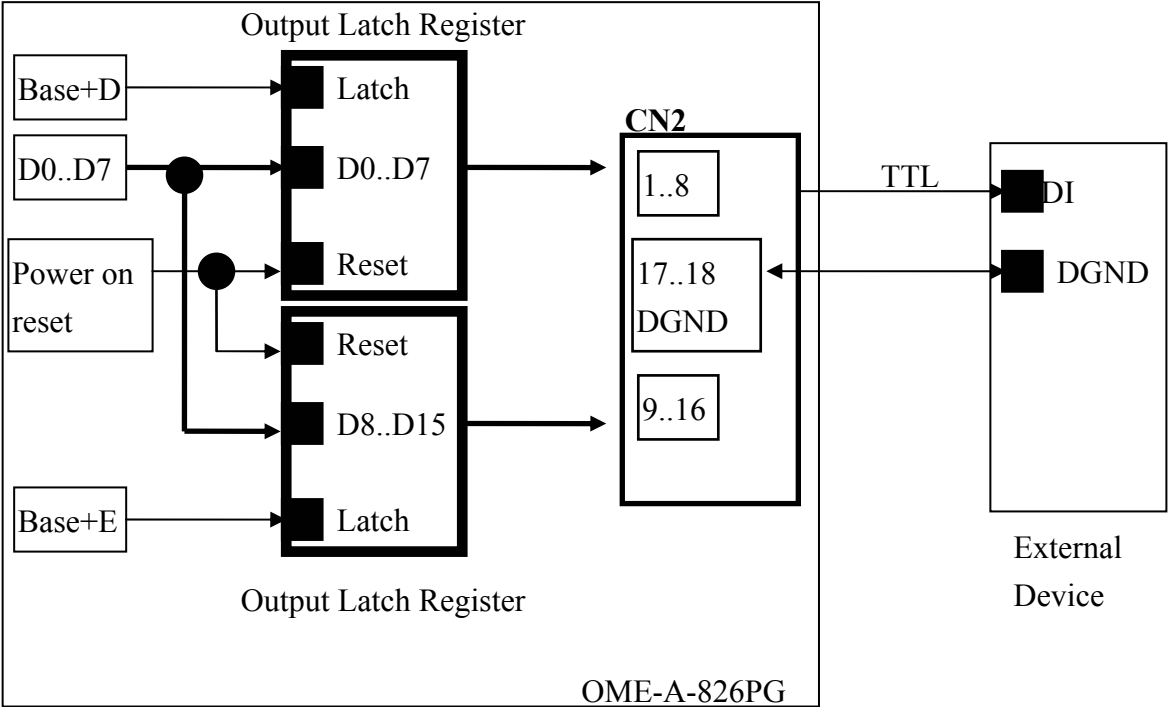
Bit 7	Bit 6	Bit 5	Bit 4	Bit 3	Bit 2	Bit 1	Bit 0
D15	D14	D13	D12	D11	D10	D9	D8

D/O 16 bits output data: D15..D0, D15=MSB, D0=LSB

The OME-A-826PG provide 16 TTL compatible digital output. The low 8 bits are stored in address **BASE+D**. The high 8 bits are stored in address **BASE+E**

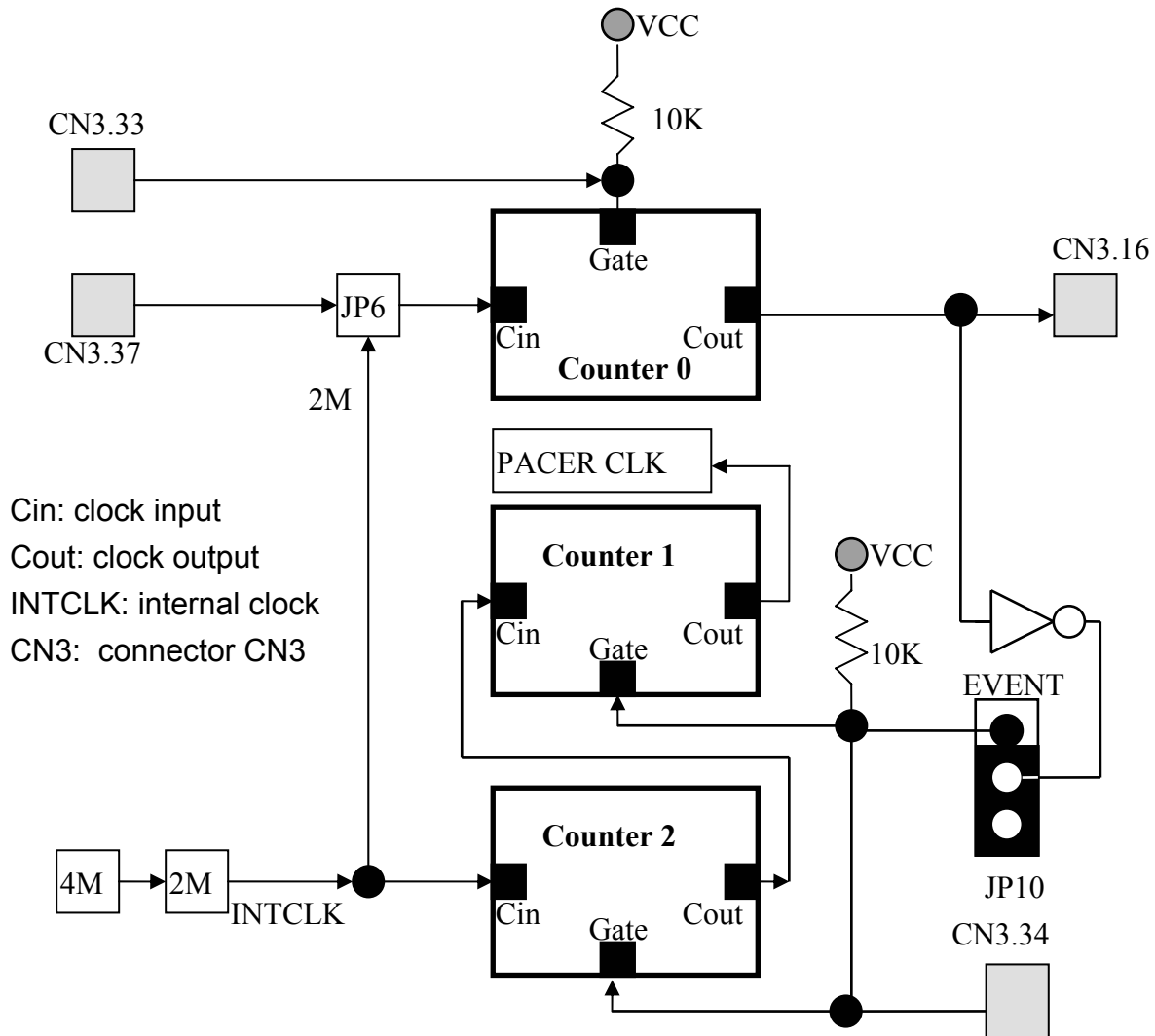
# 2.4 Digital I/O

The OME-A-826PG provides 16 digital input channels and 16 digital output channels. All signal levels are TTL compatible. The connections diagram and block diagram are given below:



## 2.5 8254 Timer/Counter

The 8254 Programmable timer/counter has 4 registers from Base+0 through Base+3. For detailed programming information about 8254, please refer to Intel's "Microsystem Components Hand book". The block diagram is as below.



The counter0, counter1 and counter2 are all 16 bits counter. The counter 1 and counter 2 cascade as a 32 bits timer. This 32 bits timer is used as **pacemaker timer**. The software driver, **A826\_Delay()**, use counter 0 to implement a machine independent timer for settling time delay. If the user doesn't use **A826\_Delay()**, the counter0 can be used as a general purpose timer/counter.

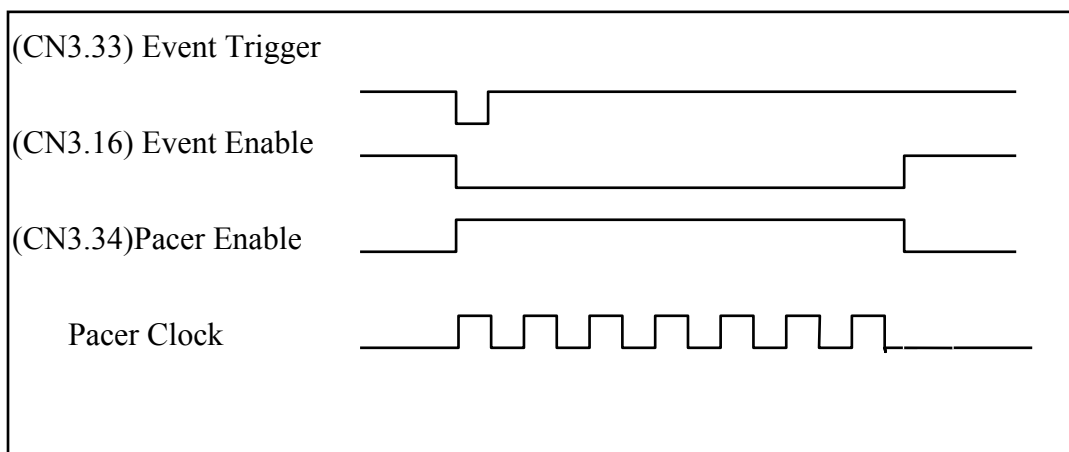
**NOTE: When the users call **A826\_Delay()** to implement a machine independent timer, the JP6 must select internal 2M clock.**

The counter 0 can be used to implement a event trigger controller. The user can send a event signal to CN3.33 to generate a START\_CONVERT (CN3.16) signal. This START\_CONVERT signal will enable the pacer timer (counter 1 & counter 2) to generate one pacer trigger signal which will feed into the A/D converter to initiate a A/D conversion cycle. The machine independent timer also use timer/counter 0, so the user can not use both the machine independent timer and the event trigger controller at the same time. If the user wants to use the event trigger controller, the JP10 must select in the correct position.. In default condition, the JP10 will set in the disable event trigger position.

The “hardware retriggerable one-shot mode” of 8254 (mode 1) can be used to implement this event trigger controller. The event signal will be in the HIGH signal level in the initial condition. After the control codes are written into the 8254 control register, the CN3.16 (Cout) will go into HIGH signal level. This HIGH signal will be inverted into the GATE input of the pacer timer (CN3.34). So the pacer timer will be in the disable state and can not generate any pacer clock output.

When the event signal go to the LOW signal level, the CN3.16 (Cout) will go to the LOW signal level. **The interval of LOW signal is called the one shot period and can be programmable by control word.** This LOW level interval signal will be inverted to enable the pacer timer to generate pacer trigger signal. **So the period of LOW level signal must be long enough to generate the desired pacer clocks.**

The event trigger controller only generate **ENABLE** signal and must be used with the pacer trigger. If the user only use event trigger controller, the hardware will generate only enable signal (missed trigger signal).





---

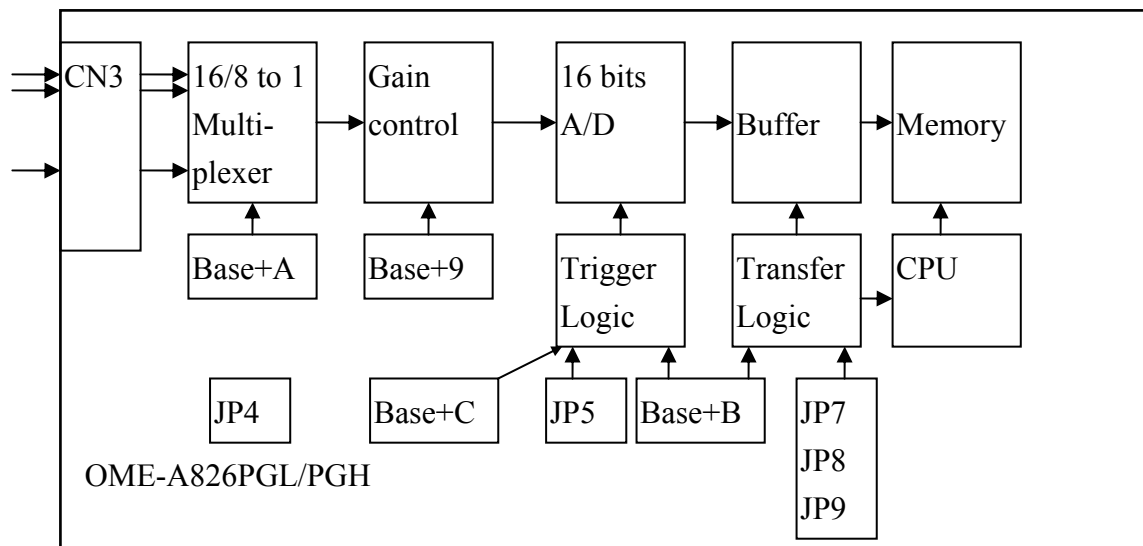
## 2.6 A/D Conversion

A/D conversion can be initiated in one of three ways: software command, internal programmable interval timer or external trigger to the A/D. At the end of the A/D conversion, it is possible to transfer the data by one of three ways: polling a status register and reading data when ready, generating a hardware interrupt and an interrupt service routine, or through DMA (direct Memory Access). All operating modes are selected by a control register on the A-826PG and are supported by the utility software.

Before use the A/D conversion function, user should notice the following issue:

- A/D data register, BASE+4/BASE+5, store the A/D conversion data.
- A/D data conversion ready register, (BASE +8) Check A/D conversion ready.
- A/D gain control register, BASE+9, select gain.
- A/D multiplex control register, BASE+A, select analog input.
- A/D mode control register, BASE+B, select trigger type and transfer type.
- A/D software trigger control register, BASE+C.
- JP4 select single-ended or differential input.
- JP5 select internal/external trigger.
- JP7 select IRQ level.
- JP6 select internal/external clock for counter0.
- JP8,JP9 select DMA channel.
- **3 trigger logic: software, pacer, external trigger.**
- **3 transfer logic: polling, interrupt, DMA.**

The block diagram is given below:..



---

## 2.6.1 A/D conversion flow

Before using the A/D converter, the user should setup the following hardware items:

1. select single-ended or differential input (JP4).
2. select internal trigger or external trigger (JP5).
3. select IRQ level if needed (JP7).
4. select DMA channel if needed (JP8,JP9).
5. select internal clock or external clock for counter0 if needed (JP6).

The software driver supports three different modes: **polling, interrupt and DMA**. The user can control the A/D conversion by polling mode very easy. It is recommended to use the software driver if using interrupt or DMA mode.

The analog input signals come from CN3. These signals may be single-ended or differential type and must match with the setting of JP3.

The multiplexer can select 16 single-ended or 8 differential signals into the gain control module. **The settling time of the multiplexer depends on the impedance of the signal source.** Because the software **does not take care the settling time, the user should delay enough settling time if switching from one channel to next channel.**

The gain control module also needs settling time if gain control code changed. Because the software **does not take care the settling time, the user should delay enough settling time if gain control code is changed.**

The software driver provides a **machine independent timer, A826\_Delay()**, for settling time delay. This subroutine assumes that JP6 select internal 2M clock and use counter0 to implement a machine independent timer. If the user call A826\_delay(), the counter0 will be reserved and can't be used as a user programmable timer/counter.

The output of gain control module feed into the A/D converter. **The A/D converter need a trigger signal to start a A/D conversion cycle.** The OME-A-826PG supports four trigger mode, **software, pacer ,event and external trigger**.

---

## 2.6.2 A/D Conversion Trigger Modes

OME-A-826PG supports three trigger modes.

### **1: Software Trigger :**

Write any value to A/D software trigger control register, BASE+A, will initiate a A/D conversion cycle. This mode is very simple but very difficult to control sampling rate.

### **2: Pacer Trigger Mode :**

The block diagram of pacer timer is show in section 2.6. The sample rate of pacer is very precise .

### **3: External Trigger Mode :**

When a rising edge of external trigger signal is applied, a A/D conversion will be performed. The external trigger source comes from pin 17 of CN3.

### **4: Event Trigger Mode:**

When the event signal go from HIGH to LOW, the event trigger controller will generate an programmable **ENABLE** interval to enable the pacer trigger. So this mode must be used with the pacer trigger mode.

## 2.6.3 A/D Transfer Modes

OME-A-826PG supports three transfer modes.

### **1: polling transfer:**

This mode can be used with all trigger mode. The detail information is given in section 2.3.18. The software scans A/D high byte data register, BASE+5, until Data Ready Register Base +8 READY\_BIT=0.The low byte data is also ready in BASE+4.

### **2: interrupt transfer:**

This mode can be used with pacer trigger or external trigger. The detail information is given in section 2.3.18. The user can set the IRQ level by adjusting JP7. A hardware interrupt signal is sent to the PC when a A/D conversion is completed.

### **3: DMA transfer:**

This mode can be used with pacer trigger or external trigger. The detail information is given in section 2.3.18. The user can set the DMA channel by adjusting JP8,JP9. Two hardware DMA requests signal are sent sequentially to the PC when a A/D conversion is completed. The single mode transfer of 8237 is suggested.

**If using interrupt or DMA transfer, it is recommended to use OME-A826 software driver.**

---

## 2.6.4 Software Trigger and Polling Technique

The simplest way to control are in the following steps :

1. send 0x01 to A/D mode control register (software trigger + polling transfer)
2. send channel number to multiplexer control register
3. send the gain control code value to gain control register.
4. send any value to software trigger control register to generate a software trigger signal.
5. scan the READY bit of the A/D high byte data until READY=0
6. read the 16 bits A/D data
7. convert this 16 bits binary data to the floating point value

Example: (QBasic Language)

```
Bas=&h220           'Set Base Address in 220 HEX
OUT Bas+11,0        'Set Soft Trigger Mode
OUT Bas+9.,0        'Set Gain=1 , Input Range = ±10
OUT Bas+10,0        'Set A/D Channel 0

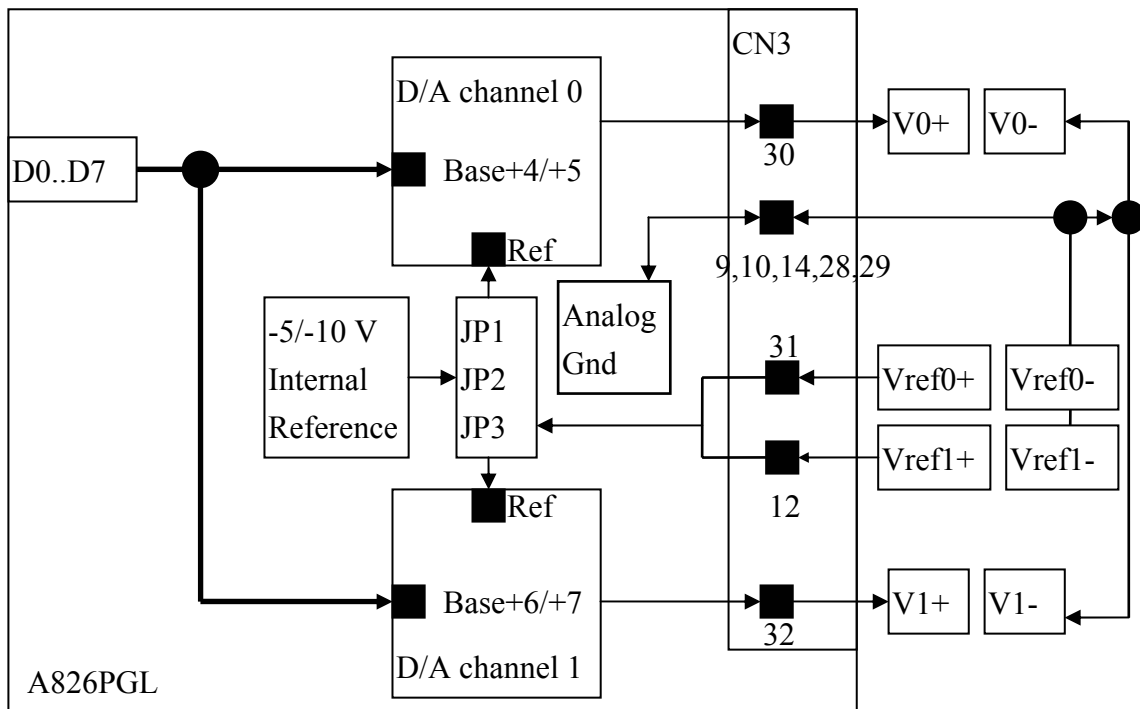
OUT Bas+12,0        'Send A/D Soft Trigger
DRDY=1
WHILE DRDY=1
  DRDY=Inp(Bas+8)   'Check DRDY = 0 Then A/D Conversion O.K
  CONVEROK=DRDY AND &H20
  If CONVEROK=0 then DRDY=1 Else DRDY=0
WEND
MSB= Inp(Bas+5)     'Read A/D High Byte
LSB = Inp(Bas+4)    'Read A/D Low Byte
Addata=MSB*256+LSB  'Conversion Binary Code to Voltage Value
If Addata >= &h8000 and Addata <= &hFFFF THEN Addata =65535-Addata
Vin = Addata * 10 / 32768
```

## 2.7 D/A Conversion

The OME-A-826PG provides two 12 bits D/A converters. Before using the D/A conversion function, user should notice the following issue:

- D/A output register, BASE+4/BASE+5/BASE+6/BASE+7.
- JP1 is used to select internal reference voltage -5V/-10V.
- JP2/JP3 is used to select internal/external reference voltage.
- If JP2/JP3 is used to select internal and JP1 select -5V, the D/A output range from 0 to 5V
- If JP2/JP3 is used to select internal and JP1 select -10V, the D/A output range from 0 to 10V
- If JP2/JP3 is used to select external, the external reference voltage can be AC/DC  $\pm 10V$

The block diagram is given as below:



NOTE: The DA output latch registers are designed as “double buffer” structure. **The user must send the low byte data first, then send the high byte data to store the DA 12 bits digital data.** If the user only sends the high byte data, then the low byte data will be still the previous value. Also if the user sends high byte first then sends low byte, the low byte data of DA is still hold in the previous one.

---

## 2.8 Analog Input Signal Connection

The OME-A-826PG can be used to measure single-ended or differential type analog input signal. Some analog signals can be measured in both of single-end or differential mode but some only can be measured in one of the single-ended or differential mode. The user must decide which mode is suitable for measurement.

In general, there are 3 different analog signal connection method as shown in Fig1 to Fig3. The Fig1 is suitable for grounding source analog input signals. The Fig2 can measure more channels than in the Fig1 but only suitable for large analog input signals. The Fig3 is suitable for thermocouple and the Fig4 is suitable for floating source

**Note: In Fig3, the maximum common mode voltage between the analog input source and the AGND is 70Vp-p, If the common mode voltage is over 70Vp-p, the input multiplexer will be damaged forever.**

The simple way to select the input signal connection configuration is as below.

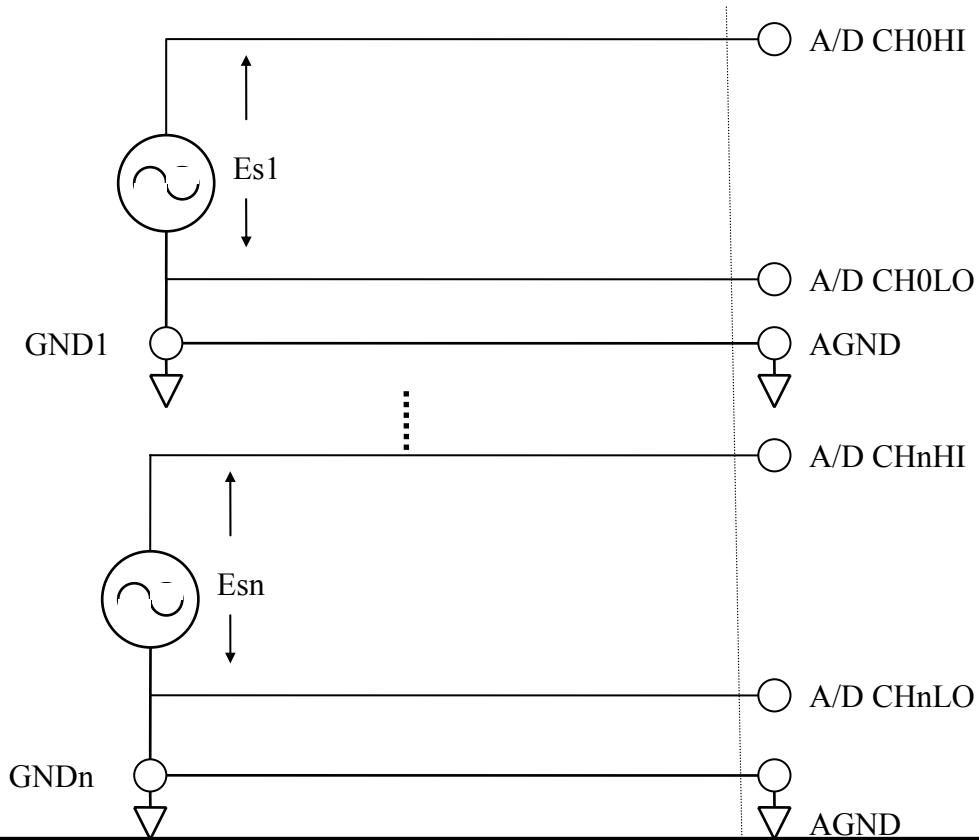
- 1. Grounding source input signal → select Fig1**
- 2. Thermocouple input signal → select Fig3**
- 3. Floating source input signal → select Fig4**
- 4. If  $V_{in} > 0.1V$  and gain $\leq 10$  and need more channels → select Fig2**

If the user can not make sure of the characteristic of input signal, the test steps are given as below:

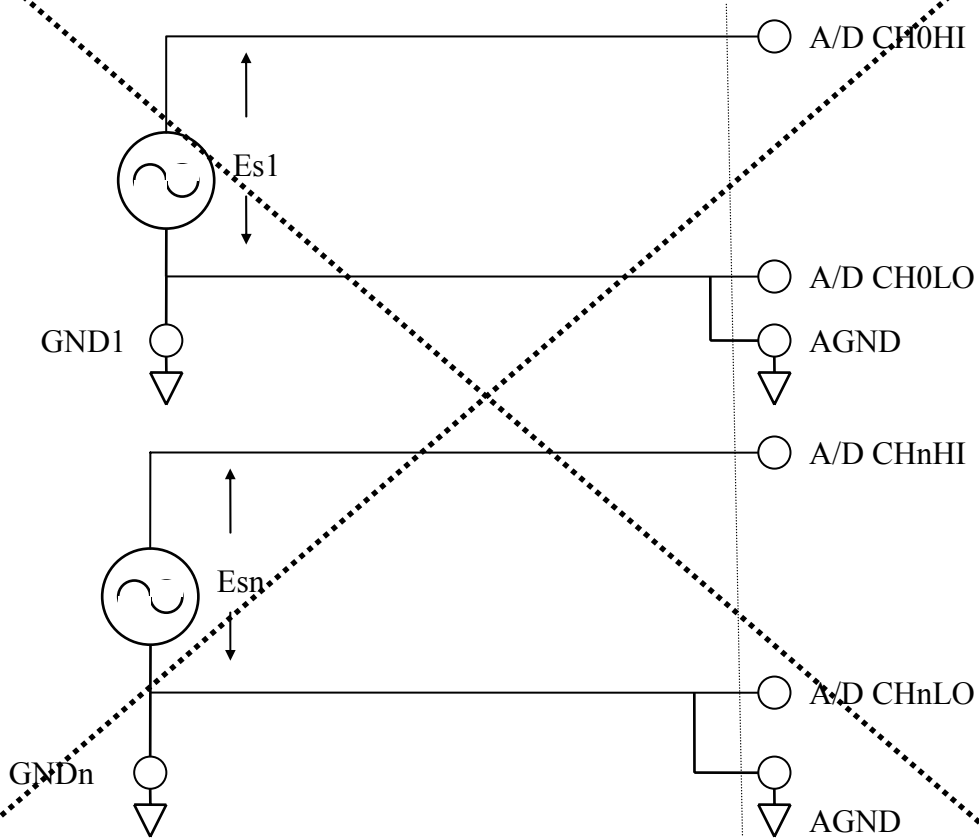
- 1. Step1: try Fig1 and record the measurement result**
- 2. Step2: try Fig4 and record the measurement result**
- 3. Step3: try Fig2 and record the measurement result**
- 4. Compare the measurement result of step 1, step 2, step 3 and select the best one**

**FIG1 : Connecting grounding source input (Right way)**

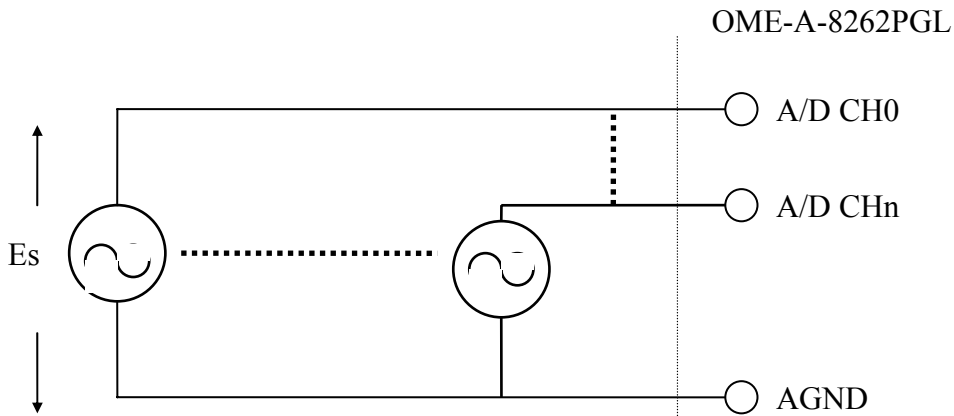
OME-A-826PG



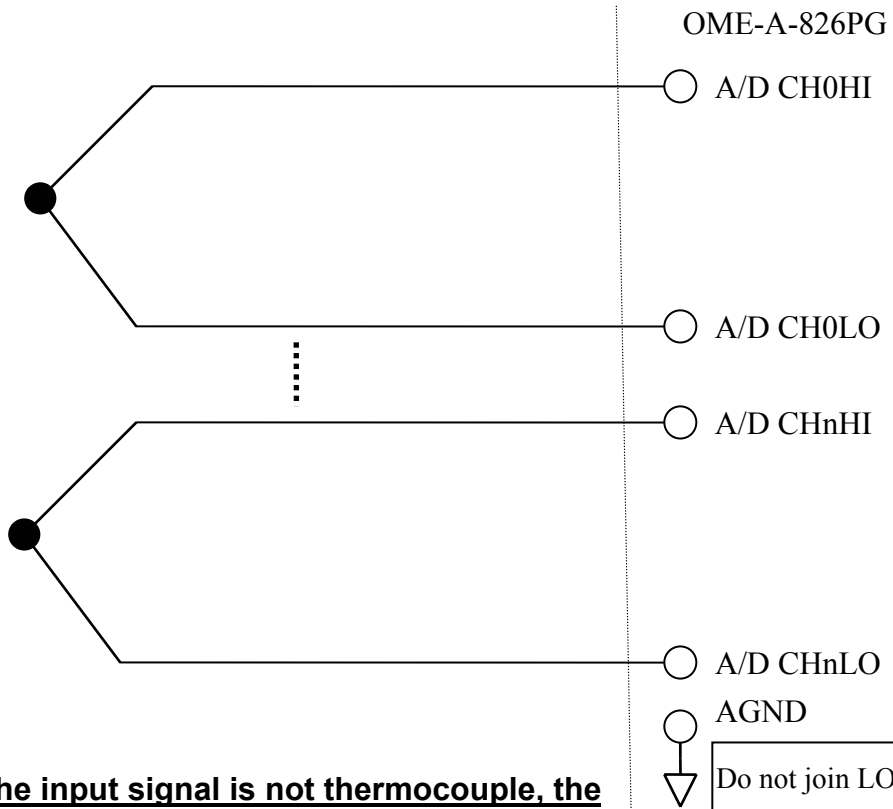
**FIG1 : Wrong way**



**FIG2 : Connecting singled-ended input**



**FIG3 : Connecting to thermocouple input**



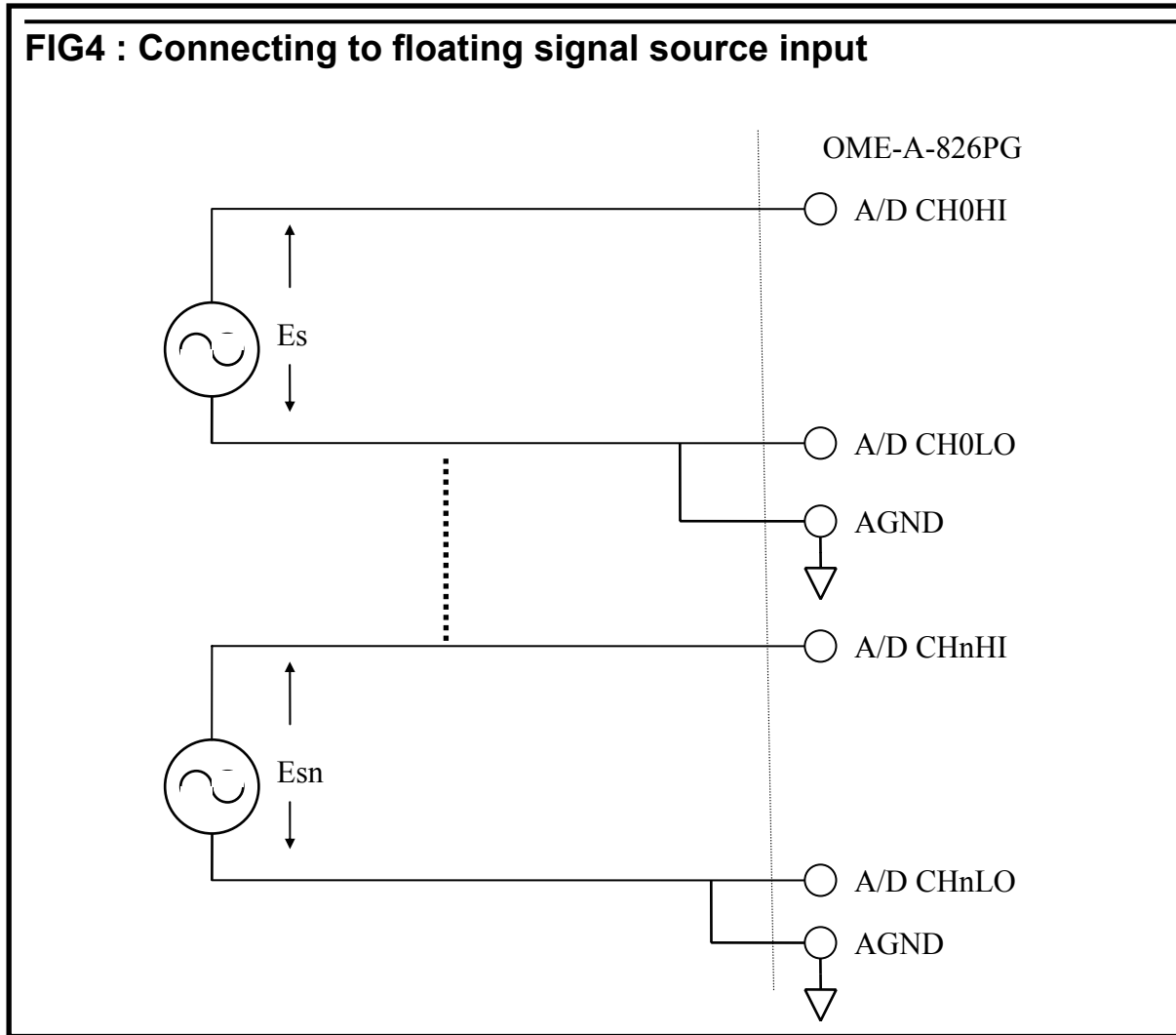
**Note: If the input signal is not thermocouple, the user should use oscilloscope to measure common mode voltage of  $V_{in}$  before connecting to OME-A-826PG. Don't use voltage meter or multimeter.**

Do not join LO to AGND at the computer

**CAUTION** : In Fig3, the maximum common mode voltage between the analog input source and the AGND is 70Vp-p, If the common mode voltage is over 70Vp-p, the input multiplexer will be damaged forever.

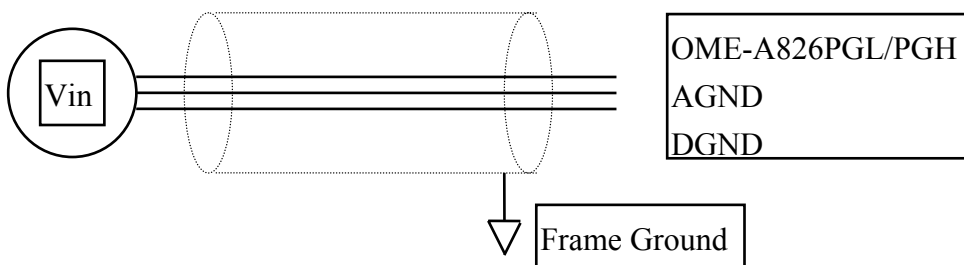


**FIG4 : Connecting to floating signal source input**



## Signal Shielding

- Signal shielding connections in Fig1 to Fig4 are all the same
- Use single-point connection to **frame ground (not AGND or DGND)**



---

## 2.9 Using OME-DB-8225 CJC Output

The CJC Circuitry on the OME-DB-8225 is used to producing 10mV per °C With 0.0 Volts @ -273 °C. The OME-A-826 Should be protected from draughts and direct sunlight in order to accurately reflect room temperature.

### CJC Calibration:

1. Connect the OME-A-826PG to OME-DB-8225 CN1
2. Set OME-A-826PG to Single-ended Mode
3. set OME-DB-8225 JP1 to 1-2 and JP2 to 2-3 ( Single-ended mode)
4. Read the temperature from a digital thermometer placed near D1/D2(See OME-DB-8265 Layout) .
5. Read OME-A-826PG analog input channel 0 (single-ended Channel 0)
6. Adjust VR1 Until a stable reading of 10mV per deg C is attained .

For example, when the environment temperature is 24°C. the reading value of CJC will be 2.97V

$$(273^{\circ}\text{C} + 24^{\circ}\text{C} ) \times 10 \text{ mV/}^{\circ}\text{C} = 2.97\text{V}$$

You should need a A/D Channel for CJC calibration. AI0 is reserved for CJC calibration use in single ended mode and CH0-HI & CH0-LO is reserved for differential mode. It is recommended to use differential mode if measuring thermocouple.

---

## 3. Pin Assignments

The OME-A-826PG provides three connectors. Connector 1, **CN1, function as 16 bits digital input.** Connector 2, **CN2, function as 16 digital output.** Connector 3, **CN3, function as analog input, analog output or timer/counter input/output.**

### 3.1 CN1/CN2/CN3 Pin Assignment

#### CN1: Digital Input Connector Pin Assignment.

Pin Number	Description	Pin Number	Description
1	Digital Input 0/TTL	2	Digital Input 1/TTL
3	Digital Input 2/TTL	4	Digital Input 3/TTL
5	Digital Input 4/TTL	6	Digital Input 5/TTL
7	Digital Input 6/TTL	8	Digital Input 7/TTL
9	Digital Input 8/TTL	10	Digital Input 9/TTL
11	Digital Input 10/TTL	12	Digital Input 11/TTL
13	Digital Input 12/TTL	14	Digital Input 13/TTL
15	Digital Input 14/TTL	16	Digital Input 15/TTL
17	PCB's GND output	18	PCB's GND output
19	PCB's +5V output	20	PCB 's +12V output

#### CN2 : Digital Output Connector Pin Assignment.

Pin Number	Description	Pin Number	Description
1	Digital Output 0/TTL	2	Digital Output 1/TTL
3	Digital Output 2/TTL	4	Digital Output 3/TTL
5	Digital Output 4/TTL	6	Digital Output 5/TTL
7	Digital Output 6/TTL	8	Digital Output 7/TTL
9	Digital Output 8/TTL	10	Digital Output 9/TTL
11	Digital Output 10/TTL	12	Digital Output 11/TTL
13	Digital Output 12/TTL	14	Digital Output 13TTL
15	Digital Output 14/TTL	16	Digital Output 15/TTL
17	PCB's GND output	18	PCB's GND output
19	PCB's +5V output	20	PCB's +12V output

### 3.1.1 FOR SINGLE-ENDED SIGNAL

**CN3 : Analog input/Analog output/Timer/Counter Connector Pin Assignment.**

Pin Number	Description	Pin Number	Description
1	Analog Input 0/+	20	Analog Input 8/+
2	Analog Input 1/+	21	Analog Input 9/+
3	Analog Input 2/+	22	Analog Input 10/+
4	Analog Input 3/+	23	Analog Input 11/+
5	Analog Input 4/+	24	Analog Input 12/+
6	Analog Input 5/+	25	Analog Input 13/+
7	Analog Input 6/+	26	Analog Input 14/+
8	Analog Input 7/+	27	Analog Input 15/+
9	PCB's analog GND output	28	PCB's analog GND output
10	PCB's analog GND output	29	PCB's analog GND output
11	D/A's internal -5V/-10V voltage reference output	30	D/A channel 0's analog voltage output
12	D/A channel 1's external voltage reference input	31	D/A channel 0's external voltage reference input
13	PCB's +12V output	32	D/A channel 1's analog voltage output
14	PCB's analog GND output	33	User timer/counter's GATE control input
15	PCB's digital GND output	34	Timer/counter 1&2's GATE control input
16	User timer/counter's output	35	Reserved
17	External trigger source input/TTL	36	Reserved
18	Reserved	37	User timer/counter's external clock input (internal=2M)
19	PCB's +5V output	XXXXXXX	This pin not available

## 3.1.2 FOR DIFFERENTIAL SIGNAL

**CN3: Analog input/Analog output/Timer/Counter Connector Pin Assignment.**

Pin Number	Description	Pin Number	Description
1	Analog Input 0/+	20	Analog Input 0/-
2	Analog Input 1/+	21	Analog Input 1/-
3	Analog Input 2/+	22	Analog Input 2/-
4	Analog Input 3/+	23	Analog Input 3/-
5	Analog Input 4/+	24	Analog Input 4/-
6	Analog Input 5/+	25	Analog Input 5/-
7	Analog Input 6/+	26	Analog Input 6/-
8	Analog Input 7/+	27	Analog Input 7/-
9	PCB's analog GND output	28	PCB's analog GND output
10	PCB's analog GND output	29	PCB's analog GND output
11	D/A's internal -5V/-10V voltage reference output	30	D/A channel 0's analog voltage output
12	D/A channel 1's external voltage reference input	31	D/A channel 0's external voltage reference input
13	PCB's +12V output	32	D/A channel 1's analog voltage output
14	PCB's analog GND output	33	User timer/counter's GATE control input
15	PCB's digital GND output	34	Timer/counter 1&2's GATE control input
16	User timer/counter's output	35	Reserved
17	External trigger source input/TTL	36	Reserved
18	Reserved	37	User timer/counter's external clock input (internal=2M)
19	PCB's +5V output	XXXXXXX	This pin not available

---

## 3.2 Daughter Board

The OME-A-826PG can be connected with many different daughter boards. The function of these daughter boards are described as follows.

### 3.2.1 OME-DB-8225

The OME-DB-8225 (or ACLD-8125 series) provides a **on-board CJC** (Cold Junction Compensation) circuit for thermocouple measurement and **terminal block** for easy signal connection and measurement. The CJC is connected to A/D channel\_0. The OME-A-826PG can connect CN3 direct to OME-DB-8225 or equivalent (ACL-8125) through a 37-pin D-sub connector.

### 3.2.2 OME-DB-37

The OME-DB-37 ( or ACLD-9137) is a **general purpose** 37-pin connector. This board direct connect to a 37-pin D-sub connector. It is suitable for easy signal connection and measurement.

### 3.2.3 OME-DB-16P

The OME-DB-16P (or 782 series) is a **16 channel isolated digital input** board. The OME-A-826PG provides 16 channel non-isolated TTL-compatible digital inputs from CN1. If connecting to OME-DB-16P, the OME-A-826PG can provide 16 channel isolated digital input signals.

### 3.2.4 OME-DB-16R

The OME-DB-16R (or 782 series) provides **16 channel SPDT relay output**. The OME-A-826PG provides 16 channel TTL-compatible digital output from CN2. If connecting to the OME-DB-16R, the OME-A-826PG can provide 16 channel relay output to control power device.

---

## 4. Calibration

The OME-A-826PG is calibrated to its best state of operation. For environment with large vibration, recalibration is recommended. Before calibrating the OME-A-826PG, the user should take care the following issues:

- One 6 digit multimeter
- One stable voltage source (4.9988V)
- Diagnostic program: this program is included in the delivered package and will guide the user to proceed the calibration.

### 4.1 Calibration VR Description

There are seven VRs on the OME-A-826PG. Calibration is needed to adjust all seven VRs.

VR Num.	Description
VR1	A/D's gain adjustment
VR2	A/D's off-set adjustment
VR3	D/A reference voltage adjustment
VR4	A/D programmable amplifier's offset adjustment
VR5	D/A channel 0's gain adjustment
VR6	D/A channel 1's gain adjustment

---

## 4.2 D/A Calibration Steps

1. Run A82XDIAG.EXE
2. Press "Right Arrow Key" to select "CALIBRATION" item
3. Press "Down Arrow Key" to select "G. D/A REFERENCE" item.
4. Press "Enter Key"
5. Connect VREF, pin 11 of CN3, to DVM (DC Voltage Meter)
6. Adjust VR3 until DVM=4.9988V
7. Press "ESC Key"
8. Select & Execute "A. D/A REFERENCE 1" item
9. Connect D/A channel 0, pin 30 of CN3, to DVM
10. Adjust VR5 until DVM=4.9988V
11. Press "ESC Key"
12. Select & Execute "B. D/A REFERENCE2" item
13. Connect D/A channel 1, pin 32 of CN3, to DVM
14. Adjust VR6 until DVM=4.9988V



---

## 4.3 A/D Calibration Steps

1. Run A82XDIAG.EXE
2. Press "Right Arrow Key" to select "CALIBRATION" item
3. Press "Down Arrow Key" to select "C. A/D REFERENCE" item.
4. Press "Enter Key"
5. Input stable 9.9997V to A/D channel 0, pin 1 of CN3
6. Adjust VR1 until A/D data shown in screen between 32765 to 32767
7. Press "ESC Key"
8. Select & Execute "D. A/D OFFSET" item
9. Input stable 0V to A/D channel 0, pin1 of CN3
10. Adjust VR1 until A/D data shown in screen between - 1 to + 1
11. Press "ESC Key"
12. Repeat step\_3 to step\_11 until no need to adjust VR2,VR1
13. Select & Execute "E. PGA OFFSET" item
14. Input stable 0V to A/D channel 0, pin 1 of CN3
15. Adjust VR6 until A/D data shown in screen between - 1 to + 1
16. Press "ESC Key"

---

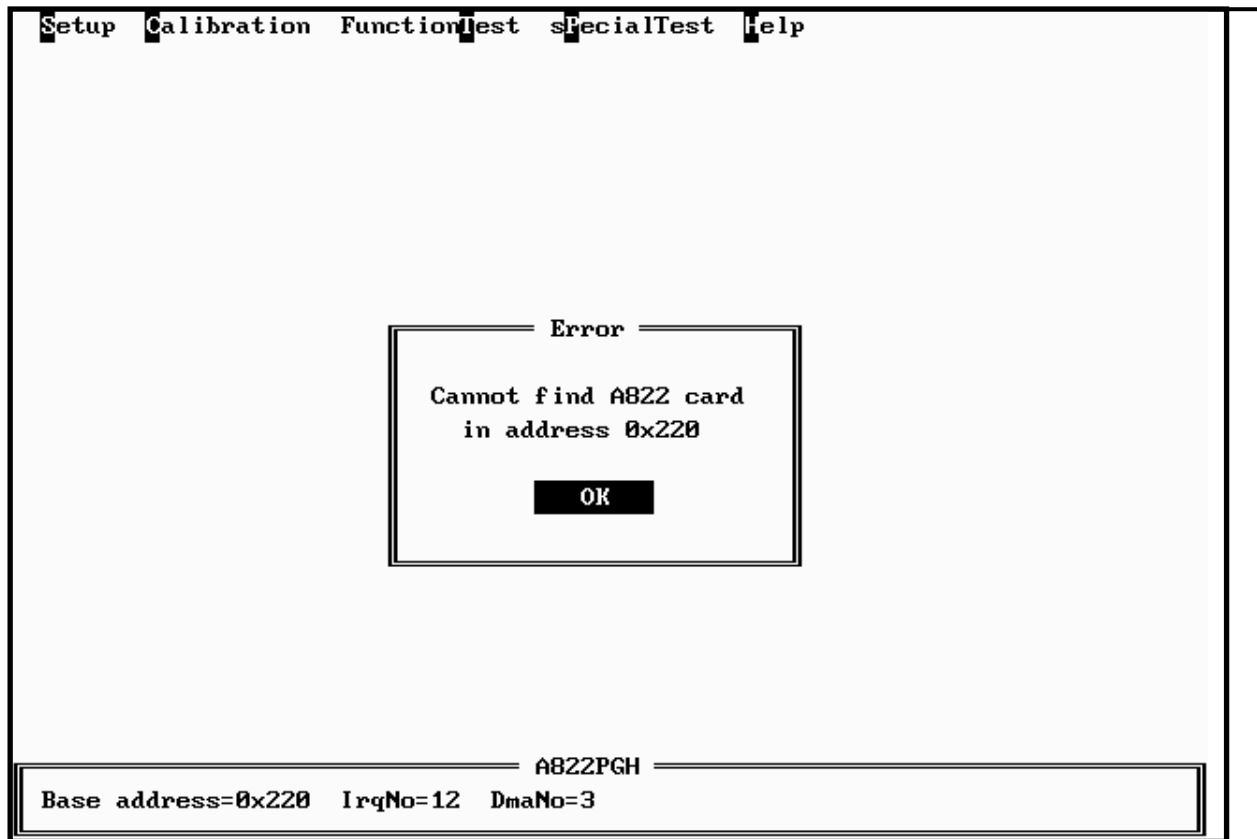
## 5. Diagnostic Utility

### 5.1 Introduction

The diagnostic utility, A82XDIAG.EXE, is a menu-driven program which gives you complete testing of the OME-A-826PG board. If you doubt the operation of the OME-A-826PG board, run the diagnostic utility to check the function of the board. To run the diagnostic utility, change to the subdirectory used in the installation process (C:\A826 for example). Then typing "A82XDIAG" <Enter> to start. These steps are shown as following:

```
C:\>CD A826 <Enter>
C:\A826>CD DIAG <Enter>
C:\A826\DIAG>A82XDIAG <Enter>
```

A configuration file, named A82X.CFG, associated with the A82XDIAG.EXE. The configuration of the OME-A-826PG board is recorded in this file. The information includes the board's I/O base address, interrupt number and DMA channel number used by OME-A-826PG. During A82XDIAG running, if you do some adjustment, the change will not be saved automatically. So the user must select the save function to save the changes. When the A82XDIAG.EXE beginning, it will automatically check if the jumper setting of I/O base address is identical to the value stored in configuration file. If the address is not identical, a error message will appear to warn you. The screen is shown as below.

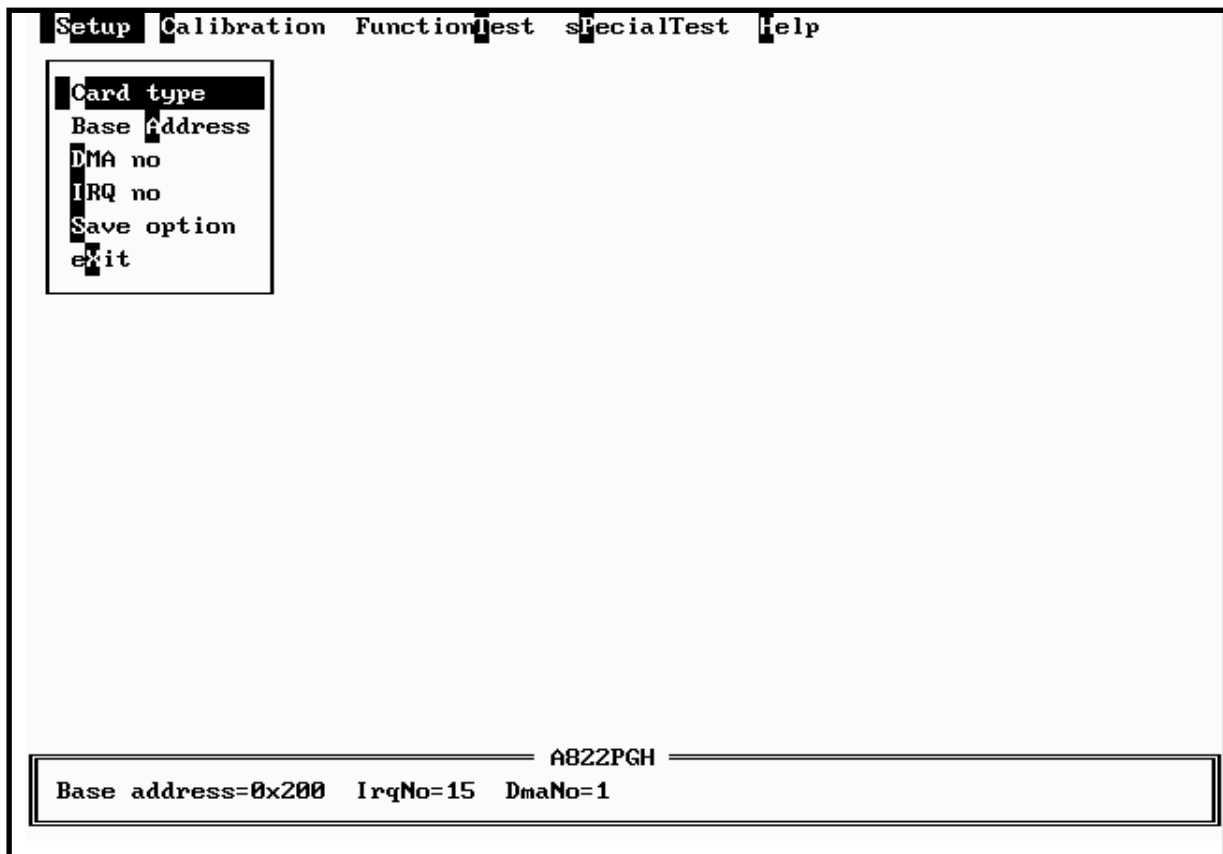


Although you can continue the A82XDIAG by press any key, it is recommended to correct this situation by setting the proper jumper setting. Because many operation in the A82XDIAG, the I/O base address is check firstly. And it don't work if the error occurs

---

## 5.2 Running The Diagnostic Utility

The initialization screen of A82XDIAG is shown below. As you can see, there are five main menus in the initialization screen. They are Setup, Calibration, Function Test, Special Test and Help. Using the Left or Right key to select the main menu, A main menu with highlight means it is selected, and some menu items are associated with it. Then using the Up or Down key to select the menu item, the selected menu item will also be highlighted. Alternately, the user can press the command key to highlight the menu item. A command key in a menu item is the character which is highlighted. To proceed with a function associated the highlighted menu item, just press <Enter>. And to press <Esc> to abort the current function.



## 5.2.1 Setup

The Setup main menu allows the user to setup the board configuration. There are six functions in this item, Card type, Base Address, DMA no, IRQ no, Save option, EXIT.

Card type : <Up/Down> key to select A-826PG, <Enter> key to select

Base Address : <Up/Down> key to select base address, <Enter> key to select

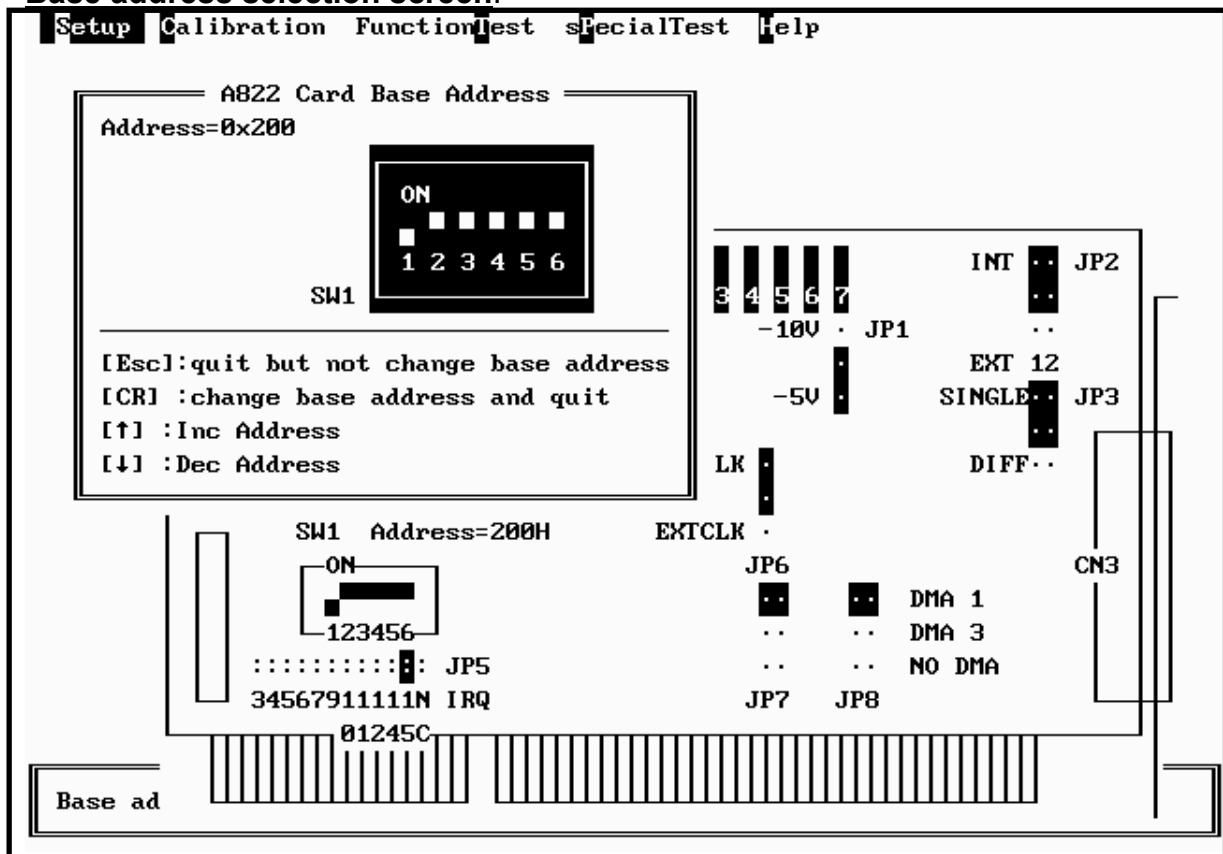
DMA no : <Up/Down> key to select DMA no, <Enter> key to select

IRQ no : <Left/Right> key to select IRQ no, <Enter> key to select

Save option : <Left/Right> key to select yes/no, <Enter> key to select

Exit : <Left/Right> key to select yes/no, <Enter> key to select

### Base address selection screen.



**DMA no and IRQ no selection screen**

Setup Calibration FunctionTest SpecialTest Help

A822 Card DMA No.

DMA=1 JP7 JP8

DMA1 .. ..

DMA3 .. ..

NODMA .. ..

---

[Esc]:quit but not change DMA No.  
 [CR]:change DMA No. and quit  
 [↑][↓]: Change setting

EXTTRG

CN2

SW1 Address=200H

ON

123456

.....: JP5

34567911111N IRQ

01245C

Base ad

1 2 3 4 5 6 7

1 -10V · JP1

2 -5V ·

INT · JP2

EXT 12

SINGLE · JP3

DIFF ·

INTCLK ·

EXTCLK ·

JP6 · · DMA 1

· · · DMA 3

· · · NO DMA

JP7 JP8

CN3

Setup Calibration FunctionTest SpecialTest Help

A822 Card IRQ No.

IRQ=15

.....

.....

3 4 5 6 7 9 1 1 1 1 1 NC

0 1 2 4 5

---

[Esc]:quit but not change IRQ No.  
 [CR]:change IRQ No. and quit  
 [→]:Inc IRQ No.  
 [←]:Dec IRQ No.

SW1 Address=200H

ON

123456

.....: JP5

34567911111N IRQ

01245C

Base ad

1 2 3 4 5 6 7

1 -10V · JP1

2 -5V ·

INT · JP2

EXT 12

SINGLE · JP3

DIFF ·

INTCLK ·

EXTCLK ·

JP6 · · DMA 1

· · · DMA 3

· · · NO DMA

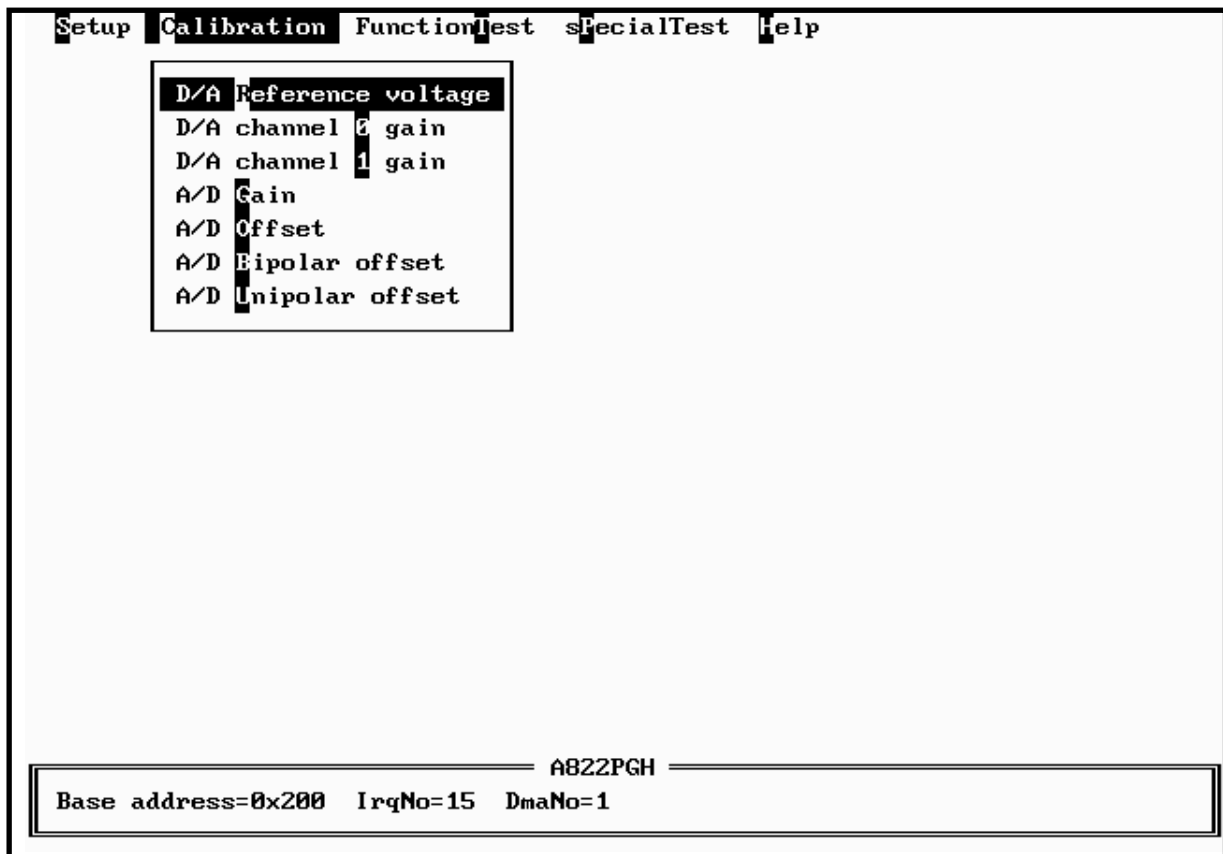
JP7 JP8

CN3

---

## 5.2.2 CALIBRATION

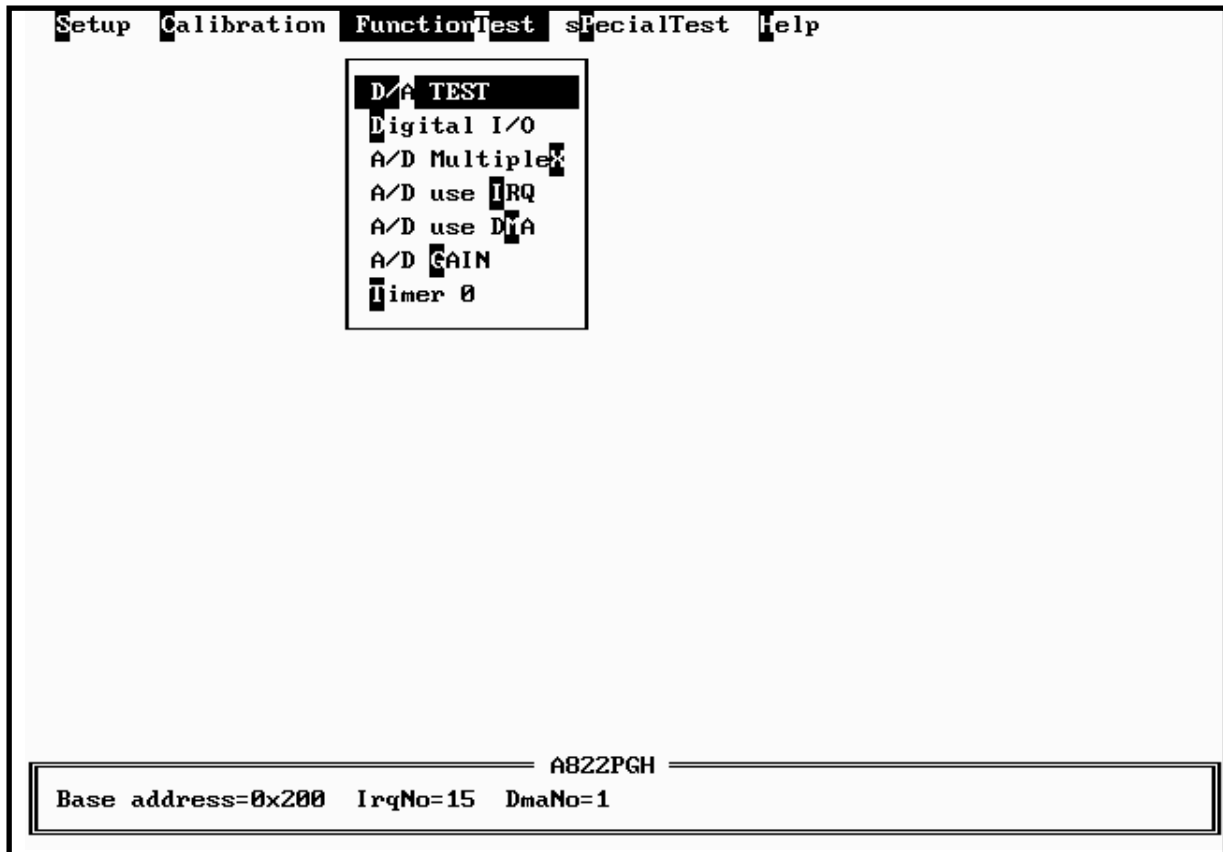
The CALIBRATION main menu contains ten menu items: they are, D/A Reference voltage, D/A Channel 0 gain, D/A channel 1 gain, A/D Gain, A/D Offset, A/D Bipolar Offset, These items are about calibration the OME-A-826PG. CALIBRATION main menu, a graphic presentation of the OME-A-826PG board's layout shown. The calibration will become as a visual process to release user's effort. To keep the optimal performance and correct precision for the board , it is needed to calibrate the board after working a long time period. There are seven VRs need to be tuned in calibration process. When you highlight one of the first seven menu item, the associated VR is blinking . And a message window will appear to indicate you how to tune the VRs. The main menu screen is shown as below.



---

## 5.2.3 FUNCTION TEST

The FUNCTION TEST main menu contains seven menu items: those are D/A TEST, Digital I/O, A/D MULTIPLEX, A/D use IRQ, A/D use DMA, A/D GAIN, Timer 0. The main menu is shown as below.



If selecting “D/A TEST” item, the screen is shown as below.



---

**<D/A TEST > test screen**

```
Setup Calibration FunctionTest SpecialTest Help

          DA Test
-----
Test count=2
  DA channel 1      DA channel 2
-----
  0333H -->  1.000V  0333H -->  1.000V
-----
[p]:pause  [Esc]:quit
[↑]:Inc delay  [↓]:Dec delay  delay= 400

          A822PGH
-----
Base address=0x200  IrqNo=15  DmaNo=1
```

- assume D/A output range 0 to 5V
- send D/A output to both channels simultaneously
- press <p> pause screen, press <p> again release screen
- press <Up> key to increase screen delay
- press <Down > key to delay screen delay
- press <ESC> key to quit

## <Digital I/O> test screen

```
Setup Calibration FunctionTest SpecialTest Help

Digital I/O TEST
Test count=154993
DO          DI          Test count=154993
Hex        Binary      Hex          Binary      Status
-----
[5D70]0101110101110000 [5D70]0101110101110000 OK.
[5D69]0101110101101001 [5D69]0101110101101001 OK.
[5D6A]0101110101101010 [5D6A]0101110101101010 OK.
[5D6B]0101110101101011 [5D6B]0101110101101011 OK.
[5D6C]0101110101101100 [5D6C]0101110101101100 OK.
[5D6D]0101110101101101 [5D6D]0101110101101101 OK.
[5D6E]0101110101101110 [5D6E]0101110101101110 OK.
[5D6F]0101110101101111 [5D6F]0101110101101111 OK.

Please use 20 pin flat cable connect CN1<->CN2 D= 0
[p]:pause [Esc]:quit [↑]:Inc delay [↓]:Dec delay

A822PGH
Base address=0x200 IrqNo=15 DmaNo=1
```

- assume CN1 direct connect to CN2
- a 16 bits up counter is send to 16 channel DO
- 16 channel DO direct connect to 16 channel DI
- 16 channel DI are readback and show in screen
- DO == DI → show OK in screen
- DO != DI → show Error in screen
- press <p> pause screen, press <p> again release screen
- press <Up> key to increase screen delay
- press <Down > key to delay screen delay
- press <ESC> key to quit

---

**<A/D Multiplexer> test screen**

Setup	Calibration	FunctionTest	SpecialTest	Help
AD TEST [Polling]				
Test count=1515				
Channel    Value				
-----				
0        4.795V				
1        3.972V				
2        3.967V				
3        3.301V				
4        4.009V				
5        3.262V				
6        2.651V				
7        1.948V				
8        1.274V				
9        0.925V				
10       0.674V				
11       0.439V				
12       0.356V				
13       0.049V				
14       -0.195V				
15       -0.459V				
-----				
A822PGH				
Base address=0x200    IrqNo=15    DmaNo=1				

- assume 16 channel single-ended, bipolar, gain=1, analog input signals
- input range from -10V to +10V
- continue scan between 16 channel
- press <ESC> key to quit

## <A/D use IRQ> test screen

```
Setup Calibration FunctionTest SpecialTest Help
----- AD TEST [Interrupt] -----
Test count=2
Channel= 0                               C1=10 C2=14 [ 14.3K Hz]
Read AD number= 999/1000                 Max= 4.958 Min= 4.934 Average= 4.942
-----
[000]: 4.939 [020]: 4.939 [040]: 4.949 [060]: 4.946 [080]: 4.941
[100]: 4.937 [120]: 4.939 [140]: 4.949 [160]: 4.951 [180]: 4.941
[200]: 4.944 [220]: 4.939 [240]: 4.939 [260]: 4.944 [280]: 4.944
[300]: 4.941 [320]: 4.941 [340]: 4.941 [360]: 4.941 [380]: 4.951
[400]: 4.944 [420]: 4.939 [440]: 4.939 [460]: 4.944 [480]: 4.941
[500]: 4.941 [520]: 4.939 [540]: 4.939 [560]: 4.944 [580]: 4.941
[600]: 4.941 [620]: 4.941 [640]: 4.941 [660]: 4.941 [680]: 4.946
[700]: 4.946 [720]: 4.941 [740]: 4.941 [760]: 4.941 [780]: 4.939
[800]: 4.939 [820]: 4.937 [840]: 4.939 [860]: 4.941 [880]: 4.941
[900]: 4.941 [920]: 4.939 [940]: 4.941 [960]: 4.941 [980]: 4.951
-----
[p]:pause [Esc]:quit
[PageUp]:Inc channel [PageDn]:Dec channel
[↑]:Inc C1 [↓]:Dec C1 [←]:Inc C2 [→]:Dec C2
-----
A822PGH
-----
Base address=0x200 IrqNo=15 DmaNo=1
```

- assume single-ended, bipolar, gain=1
- use <PgUp> key to select the next channel
- use <PgDn> key to select the previous channel
- use <Up>/<Down> key to adjust C1
- use <Left>/<Right> key to adjust C2
- sampling rate = pacer timer rate =  $2000/(C1 \cdot C2)$  K
- use <p> key to pause screen, use next <p> key to release screen
- use <ESC> to quit
- A/D mode control register=0x06 → select pacer trigger and use interrupt transfer
- one cycle sample 1000 A/D data continue
- minimal/maximal/average value shown in screen

## <A/D use DMA> test screen

```
Setup Calibration FunctionTest SpecialTest Help
----- AD TEST [Interrupt] -----
Test count=2
Channel= 0                      C1=10 C2=14 [ 14.3K Hz]
Read AD number= 999/1000        Max= 4.958 Min= 4.934 Average= 4.942
-----
[000]: 4.939 [020]: 4.939 [040]: 4.949 [060]: 4.946 [080]: 4.941
[100]: 4.937 [120]: 4.939 [140]: 4.949 [160]: 4.951 [180]: 4.941
[200]: 4.944 [220]: 4.939 [240]: 4.939 [260]: 4.944 [280]: 4.944
[300]: 4.941 [320]: 4.941 [340]: 4.941 [360]: 4.941 [380]: 4.951
[400]: 4.944 [420]: 4.939 [440]: 4.939 [460]: 4.944 [480]: 4.941
[500]: 4.941 [520]: 4.939 [540]: 4.939 [560]: 4.944 [580]: 4.941
[600]: 4.941 [620]: 4.941 [640]: 4.941 [660]: 4.941 [680]: 4.946
[700]: 4.946 [720]: 4.941 [740]: 4.941 [760]: 4.941 [780]: 4.939
[800]: 4.939 [820]: 4.937 [840]: 4.939 [860]: 4.941 [880]: 4.941
[900]: 4.941 [920]: 4.939 [940]: 4.941 [960]: 4.941 [980]: 4.951
-----
[p]:pause [Esc]:quit
[PageUp]:Inc channel [PageDn]:Dec channel
[↑]:Inc C1 [↓]:Dec C1 [←]:Inc C2 [→]:Dec C2
-----
A822PGH
-----
Base address=0x200 IrqNo=15 DmaNo=1
```

- assume single-ended, bipolar, gain=1
- use <PgUp> key to select the next channel
- use <PgDn> key to select the previous channel
- use <Up>/<Down> key to adjust C1
- use <Left>/<Right> key to adjust C2
- sampling rate = pacer timer rate =  $2000/(C1 \cdot C2)$  K
- use <p> key to pause screen, use next <p> key to release screen
- use <ESC> to quit
- A/D mode control register=0x02 → select pacer trigger and use DMA transfer
- one cycle sample 1000 A/D data continue
- minimal/maximal/average value shown in screen

---

## <DA GAIN> test screen

```
Setup Calibration FunctionTest SpecialTest Help

----- A/D Gain Test -----
GainMode=A822_BI_1                      Count=684
-----
A/D ch0=0x0BFF( 2.498)          D/A ch0=0x0800( 2.500)
-----
Please connect CN3 pin 1 to CN3 pin 30
              (A/D 0)          (D/A 0)
[Esc]:quit  [↑][↓]:Change Gain
             [←][→]:Change D/A value

----- A822PGH -----
Base address=0x200  IrqNo=15  DmaNo=1
```

- assume single-ended, bipolar, gain=1, A/D channel 0 connect to D/A channel 0
- use <Up>/<Down> key to adjust gain control code
- use <Left>/<Right> key to adjust D/A output value
- use software trigger and polling transfer mode
- press <ESC> key to quit

---

## <Timer 0> test screen

```
Setup Calibration FunctionTest SpecialTest Help

Timer 0 Test
Timer Mode=3
Value=6C1C
If value is not constant --> Timer is OK.
(CN3 pin 16 : high->low->high->low->... )
[Esc]:quit

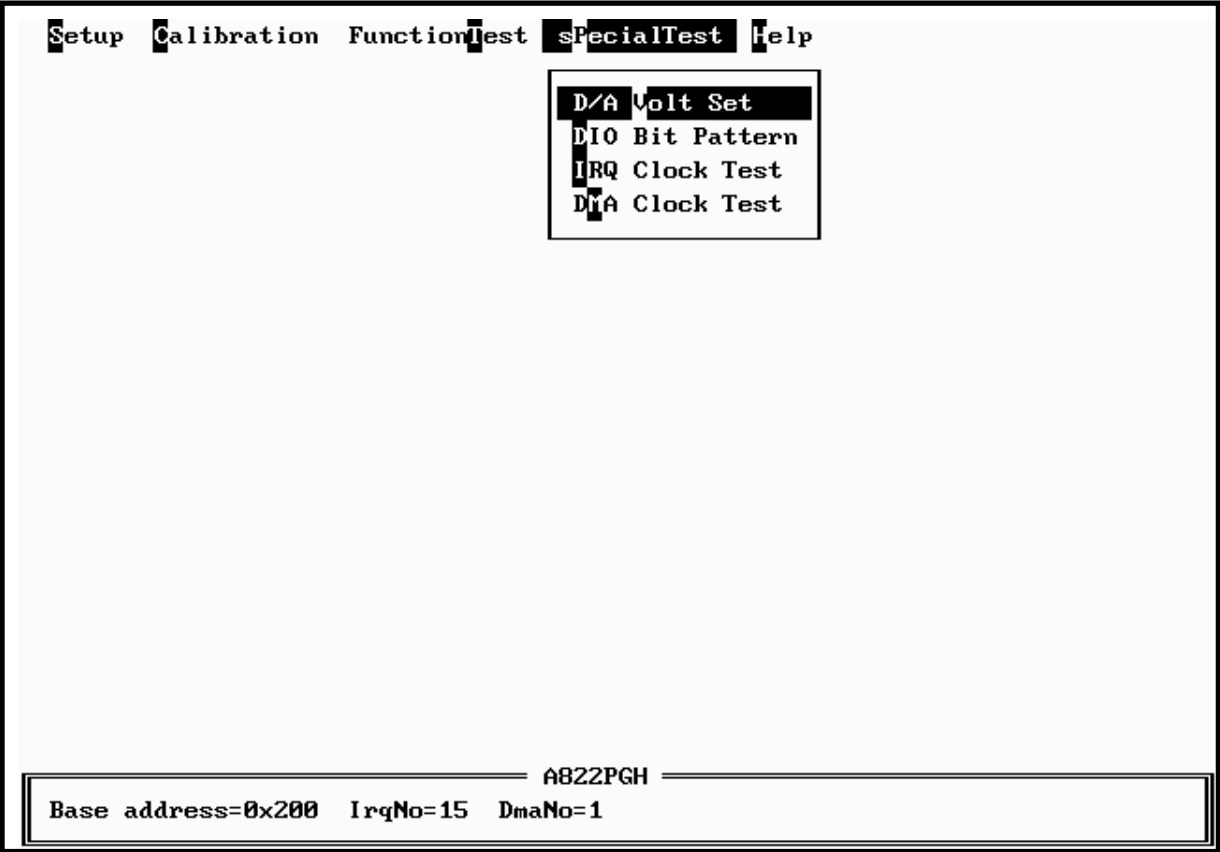
A822PGH
Base address=0x200 IrqNo=15 DmaNo=1
```

- assume JP6 select internal 2M clock
- If the counter0 is normal, the value will increment automatically. If the value is a fixed value, the counter0

---

## 5.2.4 SPECIAL TEST

The SPECIAL TEST main menu contains four menu items: those are D/A Volt Set, DIO Bit Pattern, IRQ Clock Test and DMA Clock Test. These functions are reserved for factory testing.

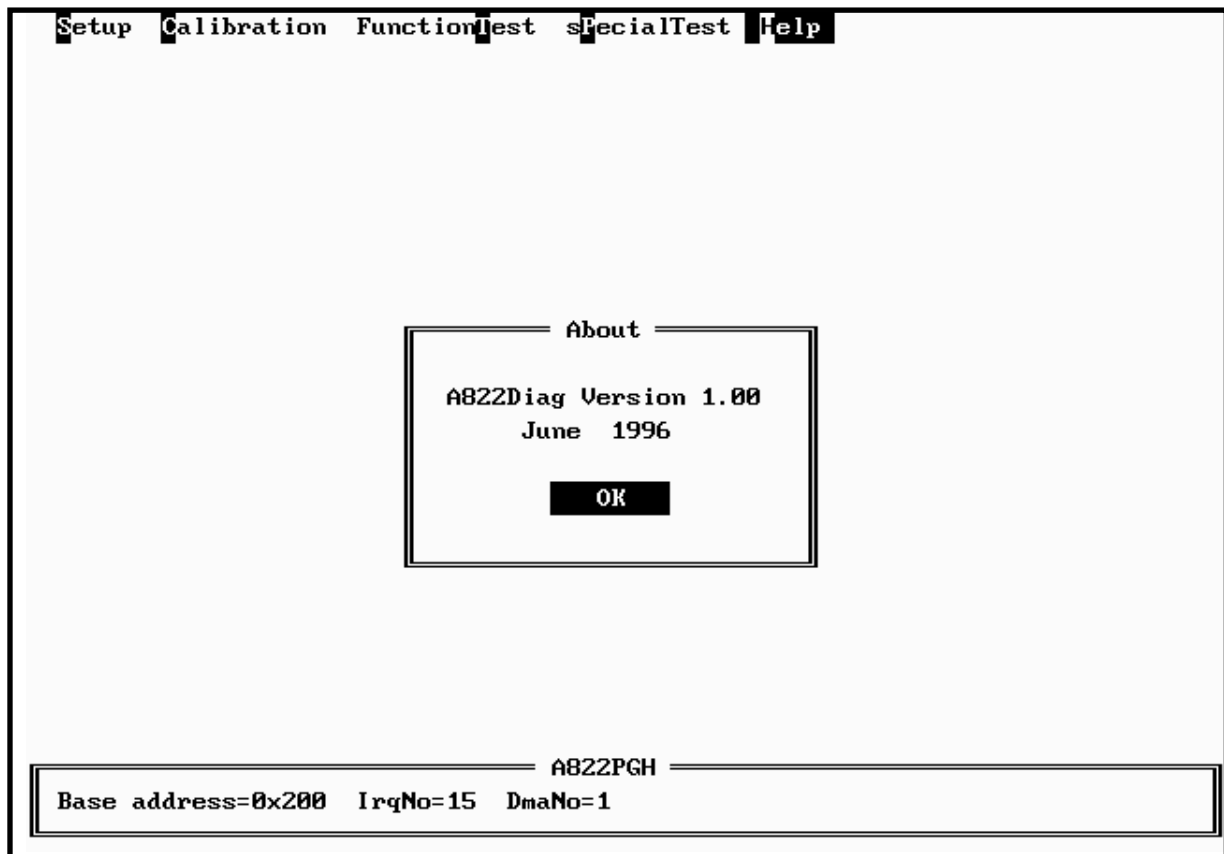




---

## 5.2.5 Help

The Help menu will show the software version as below.



## WARRANTY/DISCLAIMER

OMEGA ENGINEERING, INC. warrants this unit to be free of defects in materials and workmanship for a period of **13 months** from date of purchase. OMEGA's WARRANTY adds an additional one (1) month grace period to the normal **one (1) year product warranty** to cover handling and shipping time. This ensures that OMEGA's customers receive maximum coverage on each product.

If the unit malfunctions, it must be returned to the factory for evaluation. OMEGA's Customer Service Department will issue an Authorized Return (AR) number immediately upon phone or written request. Upon examination by OMEGA, if the unit is found to be defective, it will be repaired or replaced at no charge. OMEGA's WARRANTY does not apply to defects resulting from any action of the purchaser, including but not limited to mishandling, improper interfacing, operation outside of design limits, improper repair, or unauthorized modification. This WARRANTY is VOID if the unit shows evidence of having been tampered with or shows evidence of having been damaged as a result of excessive corrosion; or current, heat, moisture or vibration; improper specification; misapplication; misuse or other operating conditions outside of OMEGA's control. Components which wear are not warranted, including but not limited to contact points, fuses, and triacs.

**OMEGA is pleased to offer suggestions on the use of its various products. However, OMEGA neither assumes responsibility for any omissions or errors nor assumes liability for any damages that result from the use of its products in accordance with information provided by OMEGA, either verbal or written. OMEGA warrants only that the parts manufactured by it will be as specified and free of defects. OMEGA MAKES NO OTHER WARRANTIES OR REPRESENTATIONS OF ANY KIND WHATSOEVER, EXPRESS OR IMPLIED, EXCEPT THAT OF TITLE, AND ALL IMPLIED WARRANTIES INCLUDING ANY WARRANTY OF MERCHANTABILITY AND FITNESS FOR A PARTICULAR PURPOSE ARE HEREBY DISCLAIMED. LIMITATION OF LIABILITY: The remedies of purchaser set forth herein are exclusive, and the total liability of OMEGA with respect to this order, whether based on contract, warranty, negligence, indemnification, strict liability or otherwise, shall not exceed the purchase price of the component upon which liability is based. In no event shall OMEGA be liable for consequential, incidental or special damages.**

CONDITIONS: Equipment sold by OMEGA is not intended to be used, nor shall it be used: (1) as a "Basic Component" under 10 CFR 21 (NRC), used in or with any nuclear installation or activity; or (2) in medical applications or used on humans. Should any Product(s) be used in or with any nuclear installation or activity, medical application, used on humans, or misused in any way, OMEGA assumes no responsibility as set forth in our basic WARRANTY/DISCLAIMER language, and, additionally, purchaser will indemnify OMEGA and hold OMEGA harmless from any liability or damage whatsoever arising out of the use of the Product(s) in such a manner.

## RETURN REQUESTS/INQUIRIES

Direct all warranty and repair requests/inquiries to the OMEGA Customer Service Department. BEFORE RETURNING ANY PRODUCT(S) TO OMEGA, PURCHASER MUST OBTAIN AN AUTHORIZED RETURN (AR) NUMBER FROM OMEGA'S CUSTOMER SERVICE DEPARTMENT (IN ORDER TO AVOID PROCESSING DELAYS). The assigned AR number should then be marked on the outside of the return package and on any correspondence.

The purchaser is responsible for shipping charges, freight, insurance and proper packaging to prevent breakage in transit.

FOR **WARRANTY** RETURNS, please have the following information available BEFORE contacting OMEGA:

1. Purchase Order number under which the product was PURCHASED,
2. Model and serial number of the product under warranty, and
3. Repair instructions and/or specific problems relative to the product.

FOR **NON-WARRANTY** REPAIRS, consult OMEGA for current repair charges. Have the following information available BEFORE contacting OMEGA:

1. Purchase Order number to cover the COST of the repair,
2. Model and serial number of the product, and
3. Repair instructions and/or specific problems relative to the product.

OMEGA's policy is to make running changes, not model changes, whenever an improvement is possible. This affords our customers the latest in technology and engineering.

OMEGA is a registered trademark of OMEGA ENGINEERING, INC.

© Copyright 2002 OMEGA ENGINEERING, INC. All rights reserved. This document may not be copied, photocopied, reproduced, translated, or reduced to any electronic medium or machine-readable form, in whole or in part, without the prior written consent of OMEGA ENGINEERING, INC.

# Where Do I Find Everything I Need for Process Measurement and Control? **OMEGA...Of Course!**

*Shop online at [www.omega.com](http://www.omega.com)*

## **TEMPERATURE**

- ☑ Thermocouple, RTD & Thermistor Probes, Connectors, Panels & Assemblies
- ☑ Wire: Thermocouple, RTD & Thermistor
- ☑ Calibrators & Ice Point References
- ☑ Recorders, Controllers & Process Monitors
- ☑ Infrared Pyrometers

## **PRESSURE, STRAIN AND FORCE**

- ☑ Transducers & Strain Gages
- ☑ Load Cells & Pressure Gages
- ☑ Displacement Transducers
- ☑ Instrumentation & Accessories

## **FLOW/LEVEL**

- ☑ Rotameters, Gas Mass Flowmeters & Flow Computers
- ☑ Air Velocity Indicators
- ☑ Turbine/Paddlewheel Systems
- ☑ Totalizers & Batch Controllers

## **pH/CONDUCTIVITY**

- ☑ pH Electrodes, Testers & Accessories
- ☑ Benchtop/Laboratory Meters
- ☑ Controllers, Calibrators, Simulators & Pumps
- ☑ Industrial pH & Conductivity Equipment

## **DATA ACQUISITION**

- ☑ Data Acquisition & Engineering Software
- ☑ Communications-Based Acquisition Systems
- ☑ Plug-in Cards for Apple, IBM & Compatibles
- ☑ Datalogging Systems
- ☑ Recorders, Printers & Plotters

## **HEATERS**

- ☑ Heating Cable
- ☑ Cartridge & Strip Heaters
- ☑ Immersion & Band Heaters
- ☑ Flexible Heaters
- ☑ Laboratory Heaters

## **ENVIRONMENTAL MONITORING AND CONTROL**

- ☑ Metering & Control Instrumentation
- ☑ Refractometers
- ☑ Pumps & Tubing
- ☑ Air, Soil & Water Monitors
- ☑ Industrial Water & Wastewater Treatment
- ☑ pH, Conductivity & Dissolved Oxygen Instruments