

---

# ICPDAS MagicWire Release Note: Nov/2004

## **Technical Service:**

- Please send your question / suggestion / problem-report to [service@icpdas.com](mailto:service@icpdas.com).
- If you do not receive our answer within three workdays, please re-send your mail to us. (The mail may be lost on the Internet!)

## **Reporting Problems:**

Please let us know the following information. It helps us to give you answers more quickly.

1. What kinds of our products do you use?
2. Is the problem reproducible? If yes, how to do?
3. If the problem involves other programs or hardware devices, which devices or versions of the failing programs do you use?
4. Other comments relative to this problem or any suggestions will be welcomed.

We will take about two working days to test the problem you mentioned, and we will give you a reply ASAP.

---

# MA-11/12/21/22

## User Manual

### 1. Functional Description

The MagicWire series products from ICPDAS enables PLCs to talk to each other via DIO ports without adding network interface, such as Ethernet, CAN bus, Profibus, etc. By using MagicWire, many systems with non-networking PLCs can upgrade their communication capabilities immediately and can let the system perform like it consists of high-cost networking PLCs. The serial communication in MagicWire is wire-saving and suitable for the long distance remote control design. MagicWire provides communication with no software overhead. It can make 1:n data transmission; data communication faster and isochronous. MagicWire reduces the wire, the time, and the labor needed to construct a system, hence, it reduces the cost.

The MA-11, -12, -21, and -22 are MagicWire products designed to connect Mitsubishi Q series and A series PLCs via TTL DI/DO. Other compatible pin assignment PLCs can use these products as well. ICPDAS will continue to develop more MagicWire products to support other applications.

---

In general, the operating principle is structured by the strategy of delivering the 16-bit data from the specified sender address (SAn) to the corresponding receiver address (RAn) via the broadcasting method controlled by the token-stream of the network manager, SA0. Based on this algorithm, there are some general rules that need to be followed:

- The sender address needs to be unique in order to avoid any communication collisions.
- Each of FRnet needs at least one network manager defined as SA0. It plays the important role of producing the token-stream in the network.
- The baud rates of the controller and the remote module need to be the same as on one FRnet.
- The communication method is controlled by delivering the data of the specified sender address (SA) to the corresponding receiver address (RA) in the sequence of token 0 to N cyclically.

---

## 2. Specifications

- TTL logical level interface
- Connector: Fuji Female connector
- Connection:
  - Use MA-12/22 to connect the TTL input module of PLC, such as Mitsubishi A1SY71, QY71
  - Use MA-11/21 to connect the TTL output module of PLC, such as Mitsubishi A1SX71, QX71
- Power consumption: 24V @ 50mA (Max)
- Operating temperature: -20°C to 70°C Storage
- Operating humidity: 35 to 85% non-condensing
- Storage temperature: -25°C to 70°C
- Dimensions: 73 mm x 56 mm x 14 mm

### Note:

A two-wire communication cable connects MA-11/21 and MA-12/22. If the distance is less than 10 meters, a single power supply can provide the two modules by directly connecting the power cable to each other. Otherwise, each module should have an independent power supply.

### 3. Ordering Information

Module	Description
MA-11/MA-11H	250K/1M bps, SA (0.1),(2.3),(4.5),(6.7)
MA-12/MA-12H	250K/1M bps, RA (0.1),(2.3),(4.5),(6.7)
MA-21/MA-21H	250K/1M bps, SA (8.9),(10.11),..., (14.15)
MA-22/MA-22H	250K/1M bps, RA (8.9),(10.11),..., (14.15)

Note: "H" is an optional high-speed version of MA series products.

If you need high-speed version, please make contact with manufacturer.

### 4. SA/RA Address Switch Setting

#### MA11

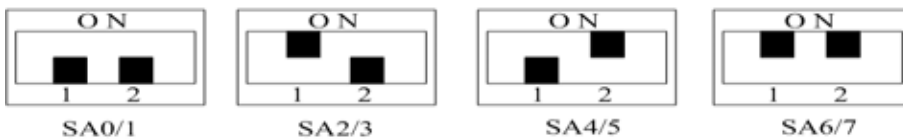

#### MA12

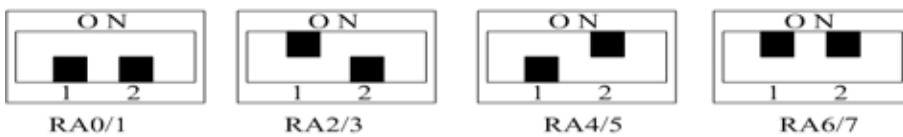

#### MA21

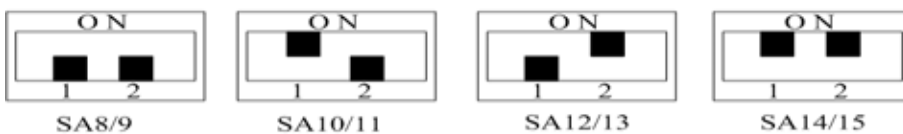

#### MA22

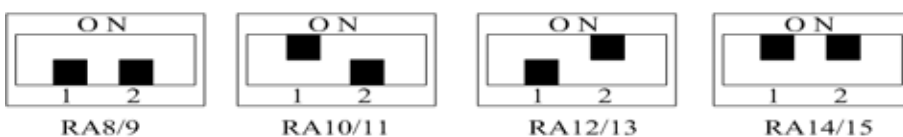

## 5. Pin Assignment

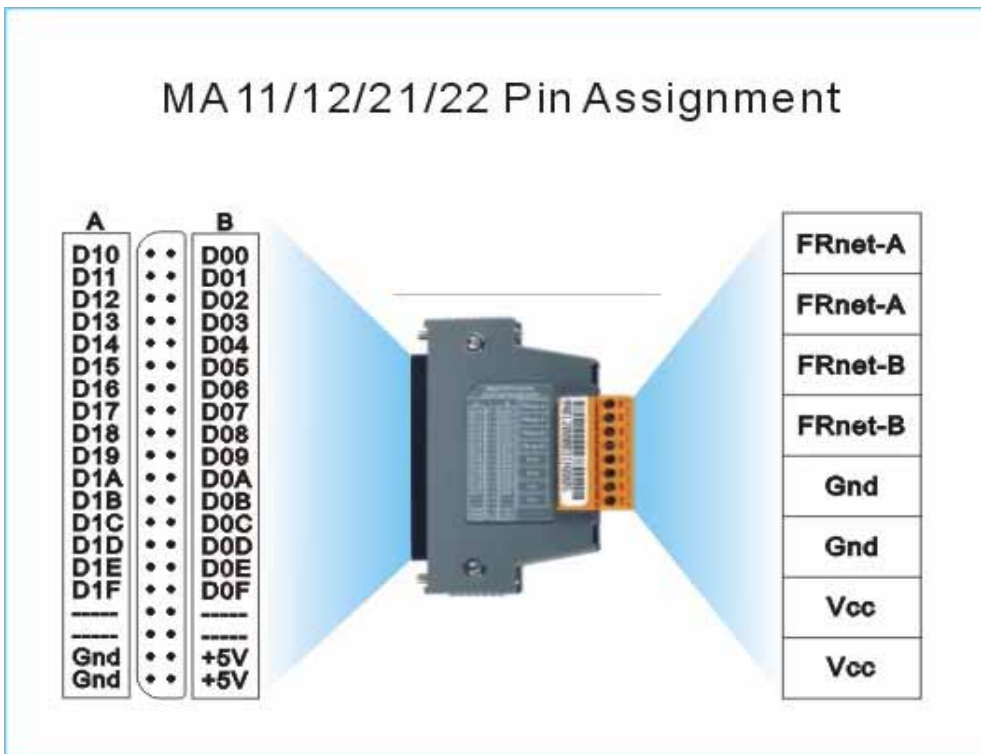

## 6. MagicWire Connection

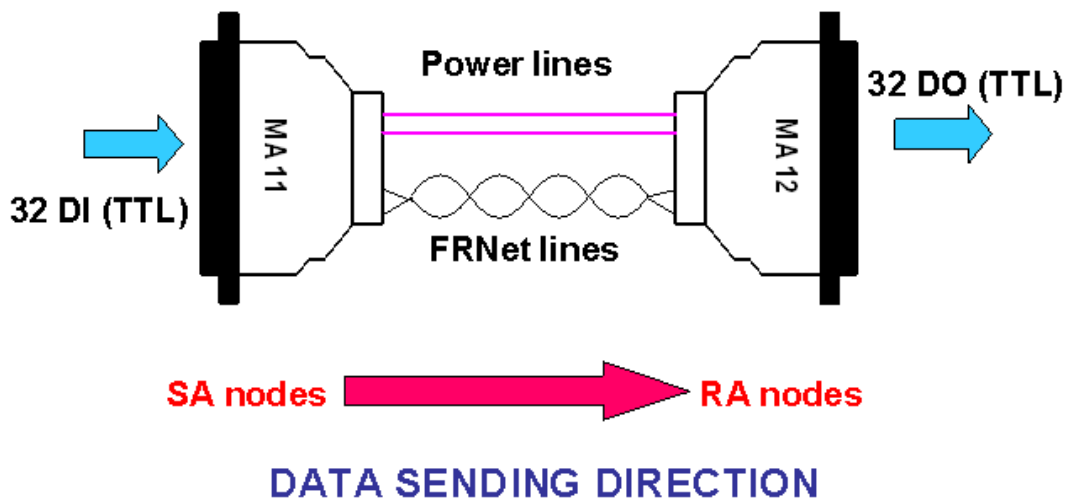

---

## 7. FRnet Application Structure

- PLCs communicate with each other via I/O:

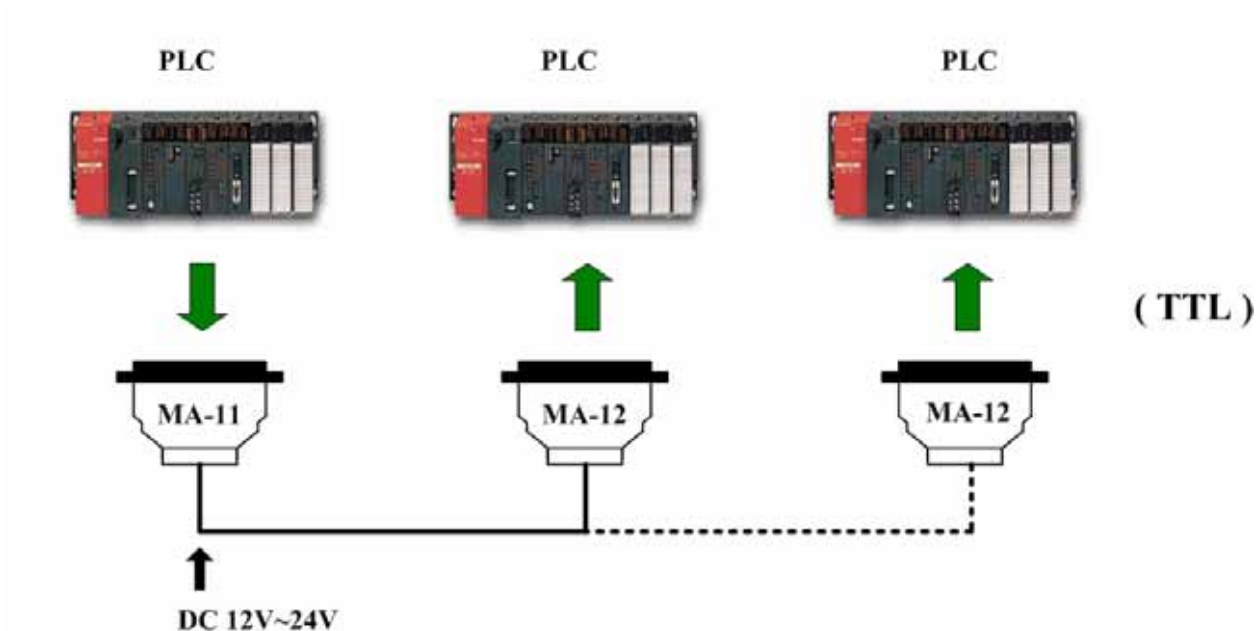

- MagicWire and Remote I/O:

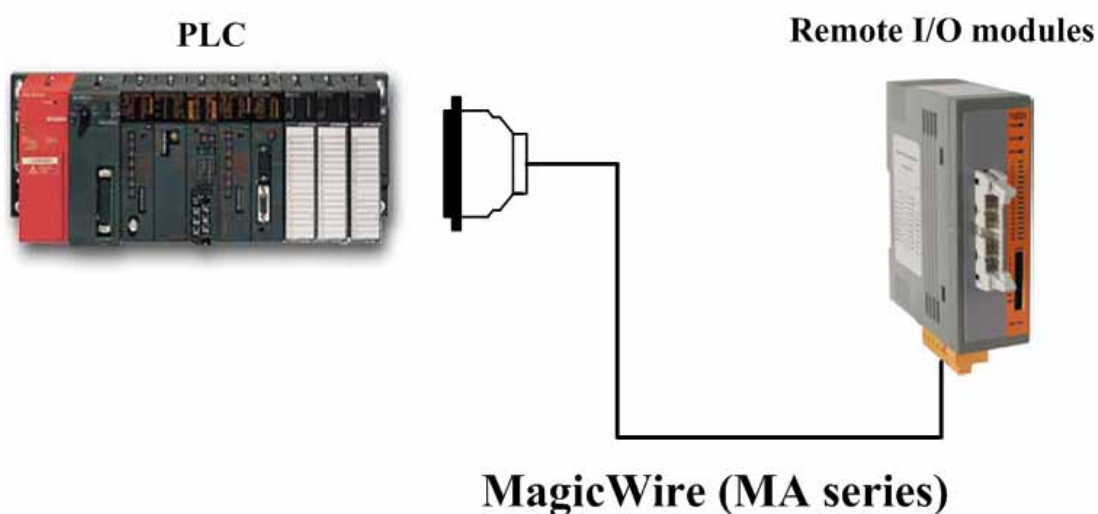

## ■ MagicWire and Embedded Controllers:

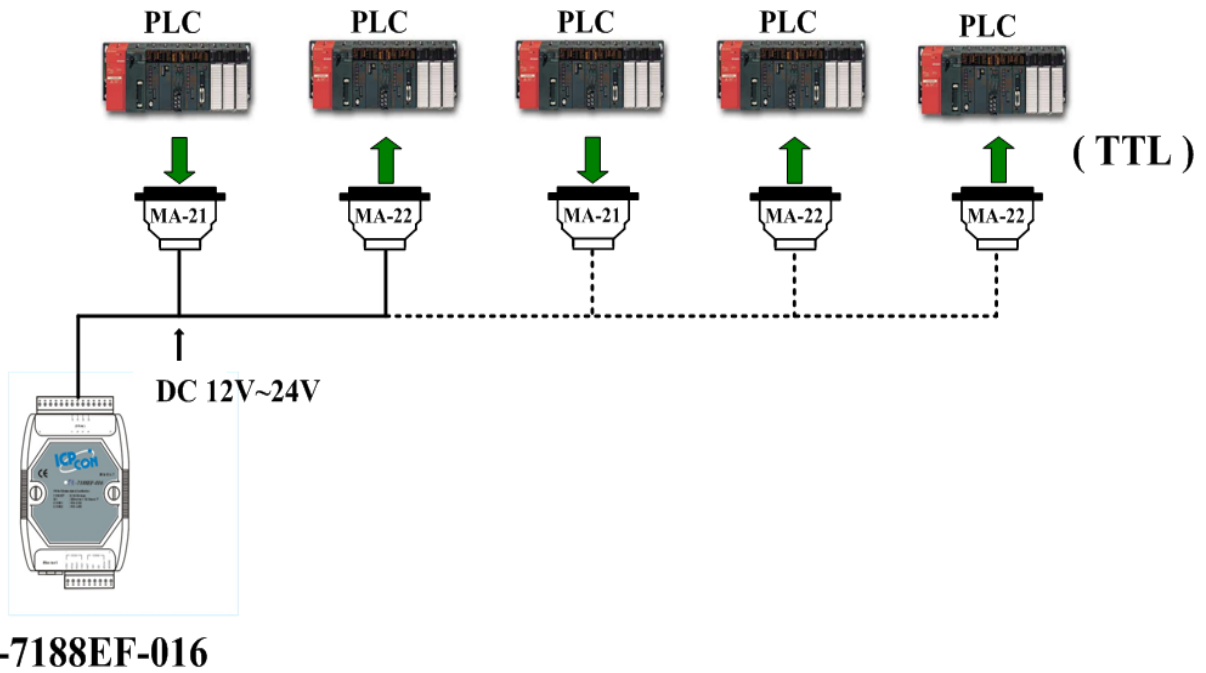

## ■ MagicWire and FRB Cards:

